

SLIP-IN FULL MORTISE TEMPLATE BUTT HINGES APPLICATION B

Size: 4 × 4"

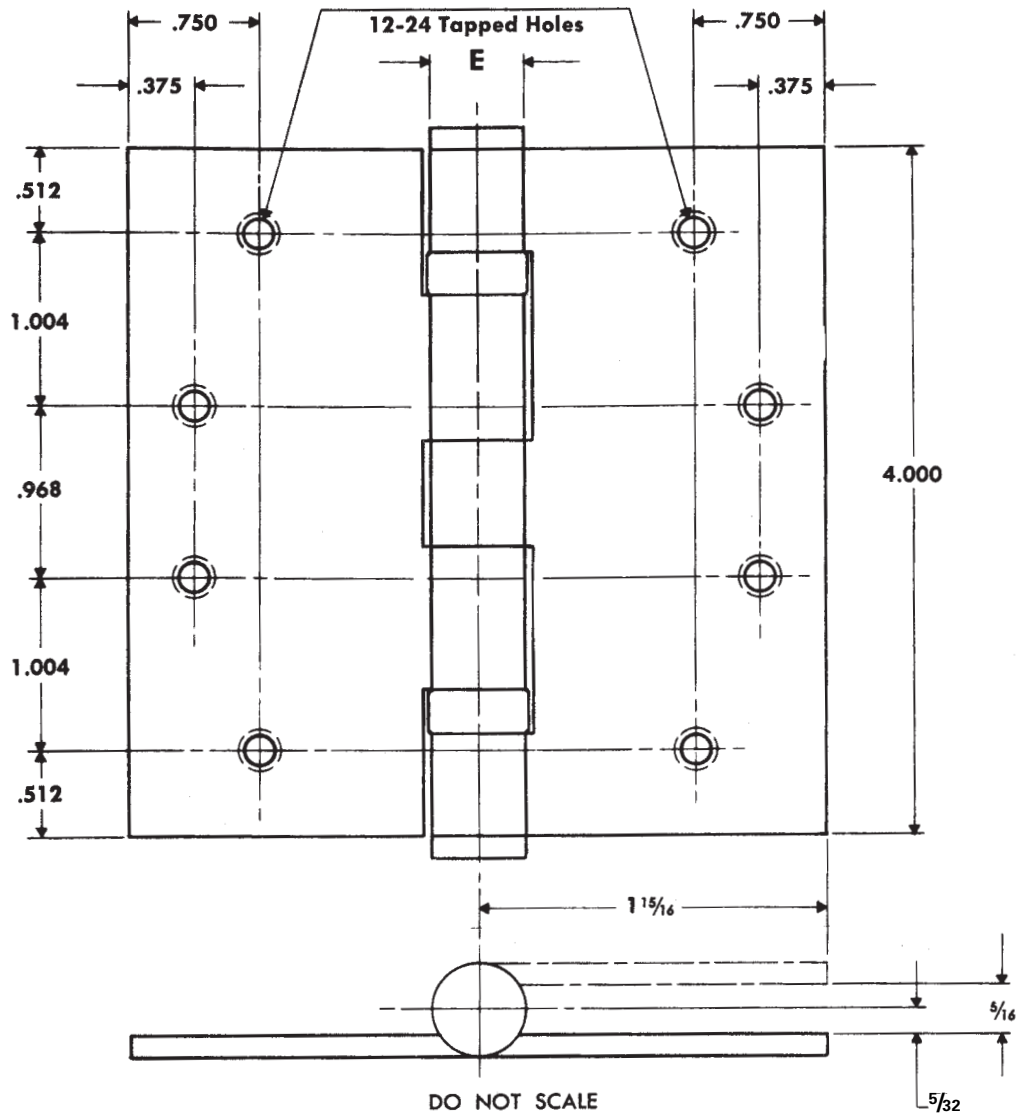

CLASS NUMBER		Gauge of Metal	(E) Outside Diameter
Steel Hinges	Nonferrous Hinges		
Slip-in CB179	Slip-in CB191	0.130	0.590
Slip-in FBB179 Application B	Slip-in FBB191 Application B		
Slip-in CB1900 Application B	Slip-in CB1960 Application B	0.130	0.540
Slip-in CB1900R Application B	Slip-in CB1960R Application B		

Machine Screw Size — ½ × 12-24 F.H.