



Installation Instructions for 83KW/93KW–85KW/95KW IDH Max Cylindrical Locks

Overview

The 83KW/93KW–85KW/95KW IDH Max Cylindrical Lock provides the following features in an integrated lock, eliminating the need to install separate sensors in and around the door frame:

- electrified locking mechanism
- electronic token reader
- integrated trim
- door status detection
- ability to exit without triggering an alarm
- compatibility with varied access control panels/reader interfaces.

Note: For a list of compatible access control panels/reader interfaces, contact your local BEST representative.

A panel interface module is provided with the lock. The panel interface module receives token data and lock sensor data from the lock through an RS-485 connection. It translates this data into parallel signals, which it sends to the access control panel/reader interface. The panel interface module also translates control signals received from the access control panel/reader interface and sends them to the lock.

The figure below shows the relationship between the components in the IDH Max system.

Contents

These installation instructions describe how to install, wire, and configure the components provided with your 83KW/93KW–85KW/95KW IDH Max Cylindrical Lock. The following topics are covered.

Site survey 2

Components checklist 2

Special tools checklist 3

Preparing the door and door jamb 4

Installing the lock and through-bolt trim 11

Completing the installation at the door 14

Installing the panel interface module 18

Testing the installation 23

Troubleshooting the installation 24

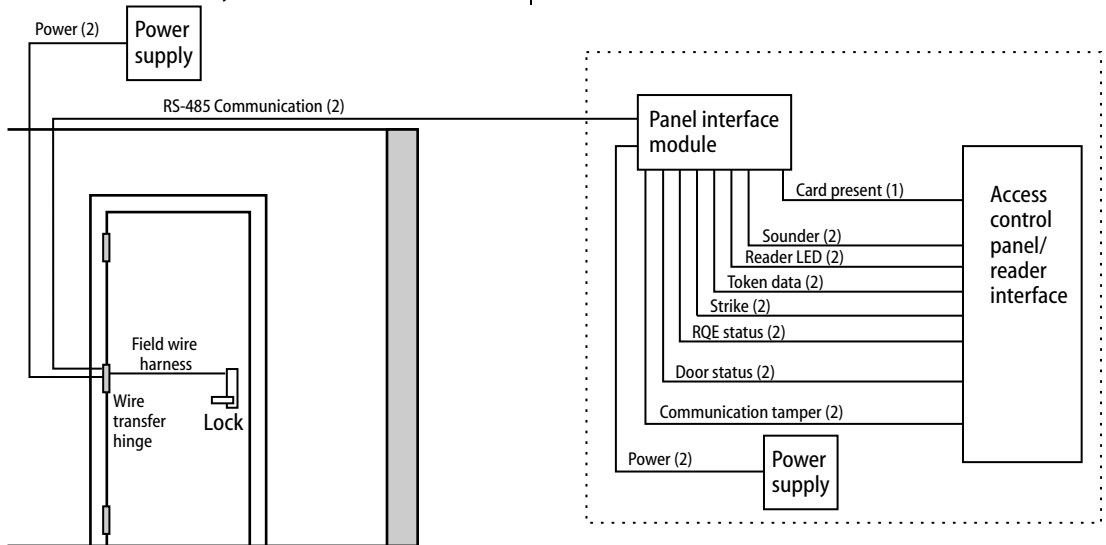

Site survey

Use the following survey to record information about the installation site. You need this information to determine field wiring needs, select a power supply, and determine how to prepare the door for the lock.

Lock information

Lock function:

- DDEL–Electrically locked
- DDEU–Electrically unlocked

Power source for lock:

- Separate power supply
- Power provided through panel interface module

Power source for panel interface module:

- Separate power supply
- Power provided through access control panel

Distance of lock site from lock power source: _____ feet

Distance of lock site from panel interface module site: _____ feet

Door information

Door handing and bevel:

- Left hand (LH)
- Left hand, reverse bevel (LHRB)
- Right hand (RH)
- Right hand, reverse bevel (RHRB)

Door thickness: _____ inches (1 3/4" – 2 1/4"; 1 3/8" with spacer)

Environment information

Ambient temperature:

- Is within specifications. See the tables below.

This product meets the following Locked Door Outdoor test requirements for ANSI/BHMA 156.25:

Side of door	Range
Inside	+66°F to +74°F (+19°C to +23°C)
Outside	–31°F to +151°F (–35°C to +66°C)

This product meets the following Full Indoor test requirements for ANSI/BHMA 156.25:

Side of door	Range
Inside and outside	+32°F to +120°F (0°C to +49°C)

Components checklist

Use the following checklist to make sure that you have the items necessary to install the components provided with your 83KW/93KW–85KW/95KW IDH Max Cylindrical Lock.

Components provided in the box:

- Chassis with outside knob/lever and outside rose liner assembly
- Inside escutcheon assembly with field wire harness
- Inside escutcheon access door
- Inside rose liner with RQE feature
- Outside escutcheon assembly
- Inside knob/lever
- Throw member package
- Latch
- Door status switch & magnet assembly
- Plastic bushing package
- Escutcheon screw package
- Panel interface module
- Strike package
- Bar code ID sticker (for your records)

Other items you'll need:

- Power supply for one IDH Max Cylindrical Lock (if you're providing a separate power supply): regulated; 12 volts DC at .85 amps

Note: *If you intend to power more than one lock with the same power supply, calculate the amperage for the power supply by multiplying .85 by the number of IDH Max Cylindrical Locks (1.1 by the number of IDH Max Mortise Locks).*

- Power supply for the panel interface module (if you're providing a separate power supply): 12 volts DC at .1 amp
- Wire transfer hinge: 8 conductors min.; 28 AWG min.

continued

Components checklist

- Field wiring for power connections between the lock and power supply or the lock and panel interface module.

If you're powering the lock(s) through the panel interface module, calculate the total length of the power wire run by summing:

- The distance from the power supply to the panel interface module.
- The distance from the panel interface module to the first door.
- If powering more than one door daisy-chained to the same power supply, add the total distance of the power runs between the doors.

If you're powering the lock(s) using a separate power supply, calculate the total length of the power wire run by summing:

- The distance from the power supply to the first door.
- If powering more than one door daisy-chained to the same power supply, add the total distance of the power runs between the doors.

Refer to the table below to determine the minimum wire gauge based on the number of doors sharing the power supply and the total length of the wire run.

Maximum wire length based on

no. of doors daisy-chained to power supply				Minimum wire gauge
1 door	2 doors	3 doors	4 doors	
250 feet	125 feet	75 feet	60 feet	18 AWG
400 feet	200 feet	130 feet	100 feet	16 AWG
600 feet	300 feet	185 feet	150 feet	14 AWG

- Field wiring for RS-485 communication connections between the lock and panel interface module (4000 feet maximum):
Category 5, shielded twisted pair; 24 AWG min.

Special tools checklist

Use the following checklist to make sure that you have the special tools necessary to install the components provided with your 83KW/93KW–85KW/95KW IDH Max Cylindrical Lock.

- three (3) to four (4) foot, 3/8" drill bit
- KD303 Drill jig
- T15 TORX® bit driver‡

‡ TORX is a registered trademark of the Camcar Division of Textron.

Preparing the door and door jamb

1 Position template and mark drill points

Note: If the door is a fabricated hollow metal door, determine whether it is properly reinforced to support the lock. If door reinforcement is not adequate, consult the door manufacturer for information on proper reinforcement. For dimensions for preparing metal doors, see the W14 Template—Installation Specifications for 83KW/93KW–85KW/95KW IDH Max Cylindrical Locks.

Note: If the door is a LH or RH door, mark the inside of the door. If the door is a LHRB or RHRB door, mark the outside of the door.

For uncut doors and frames

- 1 Measure and mark the horizontal centerline of the knob/lever (the centerline for the chassis hole) on the door and door jamb. Mark the vertical centerline of the door edge.

Note: The recommended height from the floor to the centerline of the lock is 38”.

- 2 Fold the W16 Template—Installation Template for 83KW/93KW IDH Max Cylindrical Locks on the dashed line and carefully place it in position on the high side of the door bevel.

Note: For steel frame applications, align the template’s horizontal centerline for the latch with the horizontal centerline of the frame’s strike preparation.

- 3 Tape the template to the door.
- 4 Center punch the necessary drill points. Refer to the instructions on the template.

For doors with standard cylindrical preparation

- 1 Fold the W16 Template—Installation Template for 83KW/93KW IDH Max Cylindrical Locks on the dashed line. Looking through the hole from the opposite side of the door, align the template so that you see the template outline of the 2 1/8” diameter hole.
- 2 Tape the template to the door.
- 3 Center punch the necessary drill points. Refer to the instructions on the template.

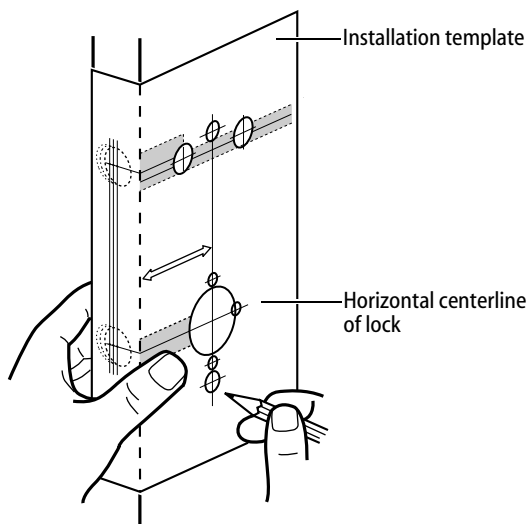

Figure 1 Positioning the template

Preparing the door and door jamb

2 Drill holes and mortise for latch face

1 Drill the holes listed below:

- upper and lower trim holes
 - 5/8" diameter
 - through door
- door status switch & LH/LHRB reader wire hole
 - 7/8" diameter
 - through door
- field harness & RH/RHRB reader wire hole
 - 7/8" diameter
 - through door
- door status switch hole
 - 1" diameter
 - meets door status switch & LH/LHRB reader wire hole
- solenoid wire hole
 - 3/8" diameter
 - through door
 - **before drilling chassis hole**
- chassis hole
 - 2 1/8" diameter
 - through door
 - after drilling solenoid wire hole
- latch hole
 - 1" diameter
 - meets chassis hole

Note 1: To locate the center of a hole on the opposite side of the door, drill a pilot hole completely through the door.

Note 2: For holes through the door, it is best to drill halfway from each side of the door to prevent the door from splintering.

2 Mortise the edge of the door to fit the latch face.

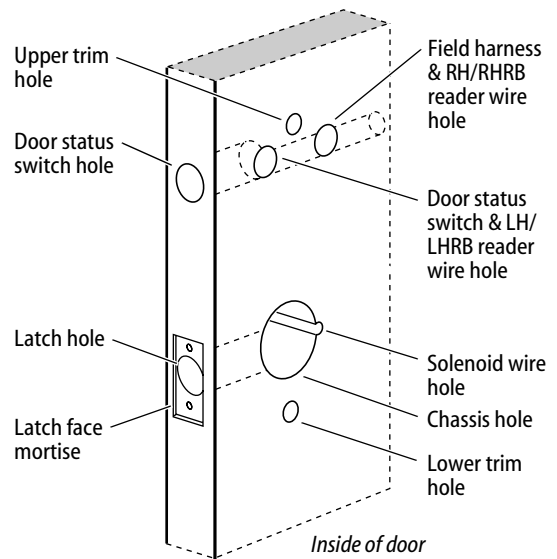

Figure 2 Drilling holes and mortising for the latch face

Preparing the door and door jamb

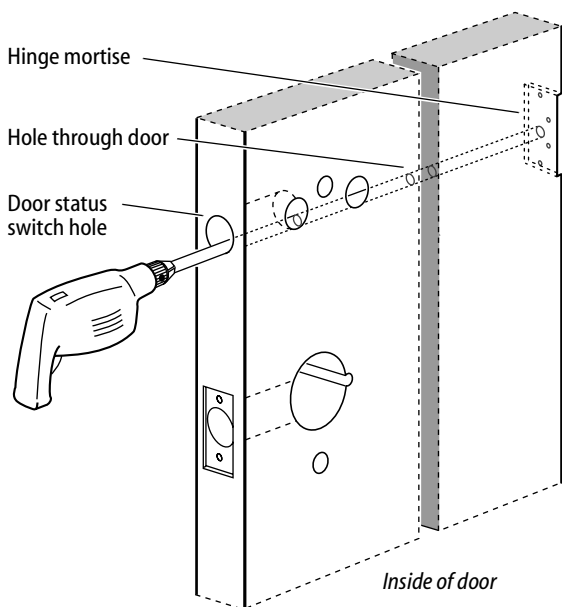

Figure 3 Drilling the hole for the field wire harness

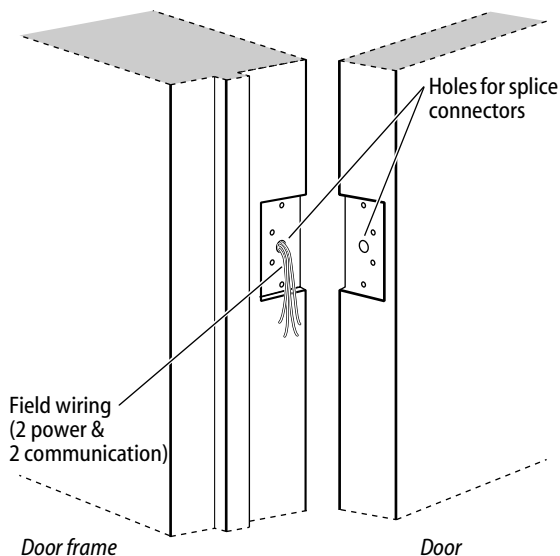

Figure 4 Preparing for the wire transfer hinge

3 Drill hole for field wire harness

Caution 1: Check with your local fire marshal before drilling a fire-rated door. Drilling through a fire-rated door may void the fire label.

Caution 2: Drill carefully through the door, making sure the drill does not break through the face of the door.

- 1 Remove the hinge nearest to the door status switch hole.
- 2 Using a three (3) to four (4) foot drill bit, drill a 3/8" diameter hole through the door, from the bottom of the door status switch hole to the center of the hinge mortise.

Note: It may be easier to drill halfway from each side of the door.

4 Prepare for wire transfer hinge and run field wiring

- 1 Drill a wire access hole through the frame side of the hinge mortise.
- 2 Drill holes (or pockets) for the splice connectors in the frame and door. Refer to the hinge manufacturer's specifications for the hole location.
- 3 De-burr the holes to prevent damage to the hinge leads.
- 4 Run the power field wiring from the location for the lock's power supply to the location for the wire transfer hinge.

Note: For an overview of the system, see the figure on page 1. For specifications for power and communication field wiring, see Components checklist, on page 2.

- 5 Run the communication field wiring from the location for the panel interface module to the location for the door transfer hinge.
- 6 Pull the field wiring down the wall and through the access hole in the frame.

Preparing the door and door jamb

5 Install latch

- 1 Install the latch in the door.

Note: *The latch tube prongs should be centered and should project into the chassis hole.*

- 2 Check that the door swings freely.

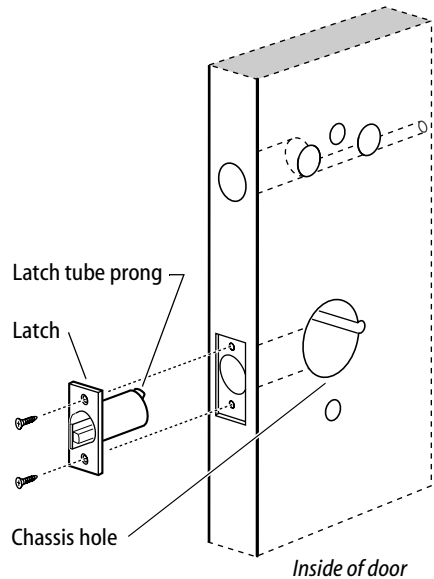

Figure 5 Installing the latch in the door

6 Use drill jig to drill through-bolt holes (9KW only)

- 1 Press the drill jig (KD303) onto the door, engaging it with the latch tube prongs. Make sure the front edge of the jig is parallel with the door edge.
- 2 Drill the through-bolt holes (5/16" diameter) halfway into the door.
- 3 Turn the drill jig over and repeat steps 1 and 2 from the opposite side of the door.

Note: *Replace the drill jig after 10 door preparations.*

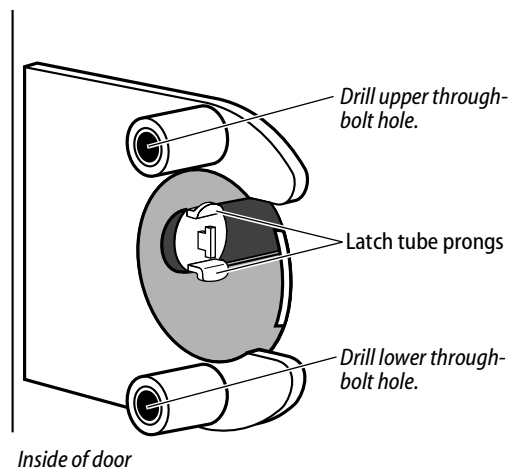

Figure 6 Installing the drill jig and drilling the through-bolt holes

Preparing the door and door jamb

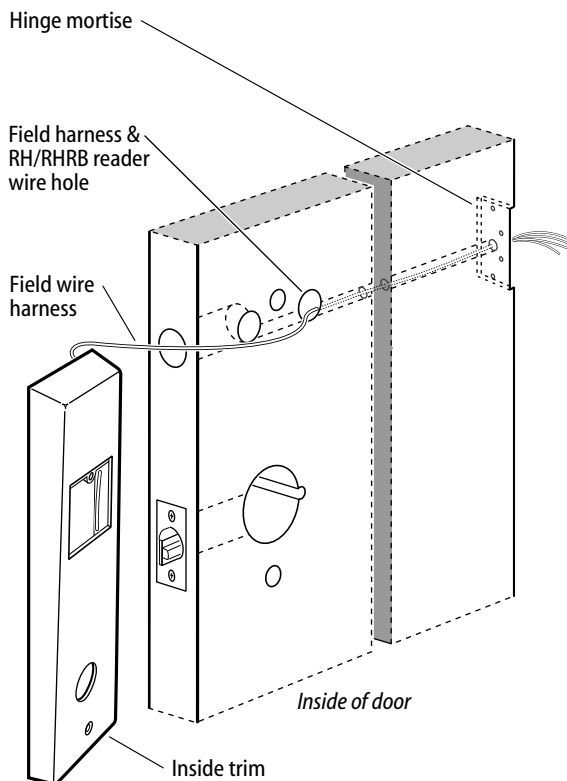

Figure 7 Pulling the field wire harness through the door

7 Pull field wire harness through door

- 1 Feed the field wire harness (connected to the inside trim) into the field harness & RH/RHRB reader wire hole and down into the hole drilled through the door to the hinge mortise.
- 2 From the latch edge of the door, fish the field wire harness through the door to the hinge mortise.
- 3 Make sure there are 3" to 4" of slack in the field wire harness to allow access to the control electronics circuit board in the inside trim.

Note: You can let the trim dangle from the field wire harness while completing tasks 8 through 14.

Preparing the door and door jamb

8 Install door status switch and magnet

- 1 On the door jamb, mark the drill point for the 1" diameter magnet hole. This hole should be directly opposite the door status switch reader wire hole when the door is closed.
- 2 Drill a 1" diameter hole for the magnet, at least 1 3/4" deep.
- 3 Insert the magnet in the hole.
- 4 Insert the door status switch assembly into the door status switch hole in the edge of the door, feeding the connectors out the wire hole to the inside of the door, as shown in Figure 8.

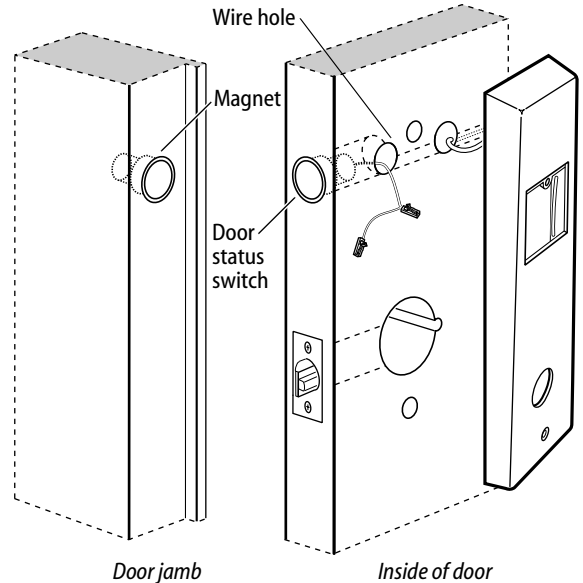
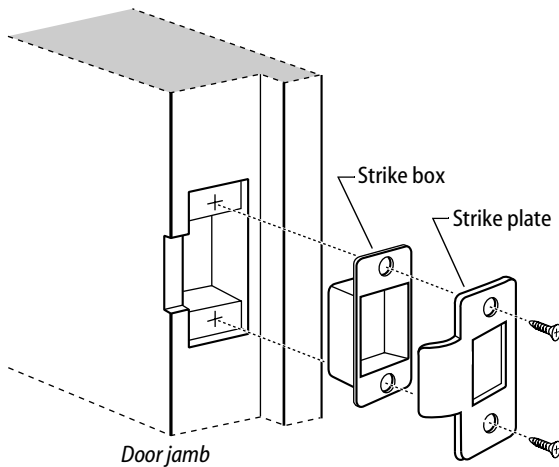

Figure 8 Installing the door status switch and magnet

Preparing the door and door jamb



9 Install strike box and strike plate

- 1 In alignment with the center of the latchbolt, mortise the door jamb to fit the strike box and strike plate.
- 2 Insert the strike box and secure the strike with the two screws provided.
- 3 Check the position of the deadlocking plunger against the strike plate.

Caution: The deadlocking plunger of the latchbolt must make contact with the strike plate, as shown in Figure 9b. The plunger deadlocks the latchbolt and prevents someone from forcing the latch open when the door is closed.

Figure 9a Installing the strike box and strike plate

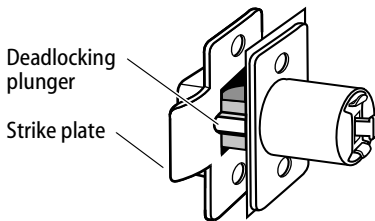

Figure 9b Aligning the deadlocking plunger with the strike plate

Installing the lock & through-bolt trim

10 Remove outside knob/lever

- 1 Insert the control key into the core and rotate the key 15 degrees to the right.
- 2 Insert a flat blade screwdriver into the figure-8 core hole and into the knob/lever.
- 3 Press the screwdriver blade in the direction of the arrow in Figure 10.

Note: You cannot remove the knob/lever if the screwdriver blade is inserted too far past the keeper.

- 4 Slide the knob/lever off of the sleeve.

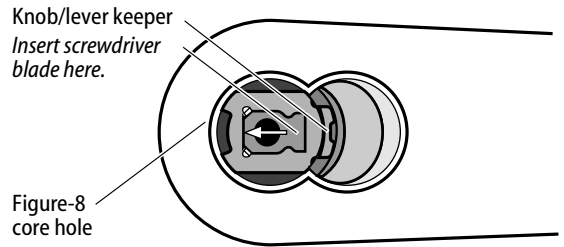

Figure 10 Removing the outside knob/lever

11 Adjust for door thickness

- 1 Determine the door's thickness.
- 2 Pull the rose locking pin and rotate the outside rose liner until the proper groove on the through-bolt stud lines up with the hub face.

Note 1: Make sure that the locking pin fully locks into the rose liner.

Note 2: The lockset fits doors 1 3/4" to 2 1/4" thick. (A spacer is available for 1 3/8" doors.)

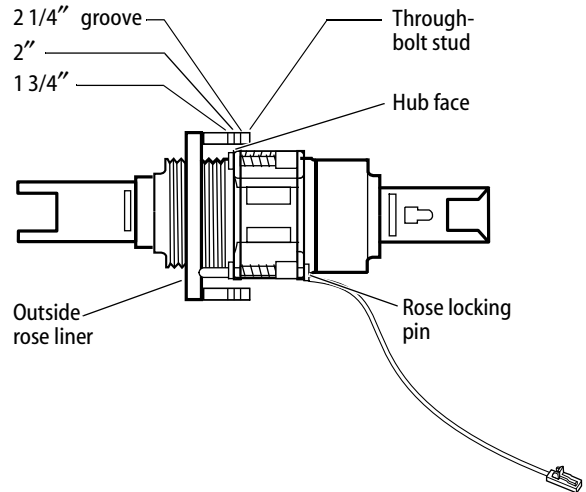

Figure 11 Adjusting the rose liner for the door thickness

Installing the lock & through-bolt trim

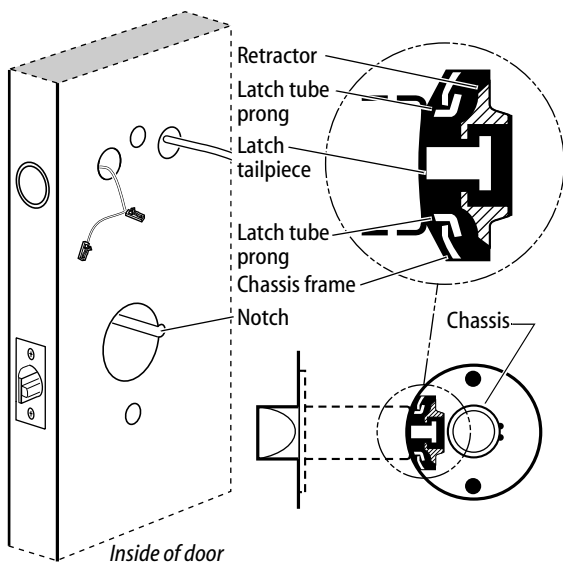

Figure 12 Installing the lock chassis and engaging the retractor in the latch

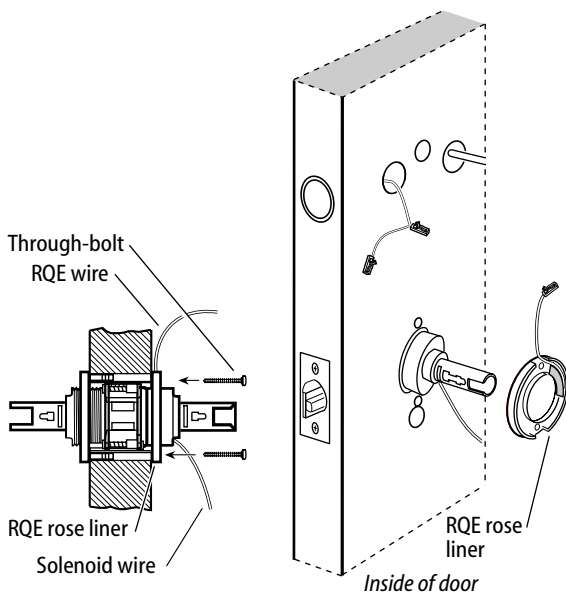

Figure 13 Installing the through-bolts and RQE rose liner

12 Install lock chassis and engage retractor in latch

From the outside of the door, insert the lock chassis into the 2 1/8" chassis hole, routing the solenoid wire through the notch.

Caution: Make sure that the latch tube prongs engage the chassis frame and that the latch tailpiece engages the retractor.

13 Install through-bolts and RQE rose liner

- 1 Place the RQE rose liner on the chassis, aligning the holes in the rose liner with the holes prepared in the door.

Caution: Make sure that there is clearance for the solenoid wire between the RQE rose liner and the door.

- 2 Install the through-bolts through the RQE rose liner and door in the top and bottom holes.
- 3 Tighten the RQE rose liner on the door with the through-bolts.

Note: You do **not** need to change the positions of the DIP switches on the control electronics circuit board located in the inside escutcheon.

- By default, switches 1 through 5 are set to ON. These switches are for possible future applications.
- By default, switches 6 and 7 are set to ON for automatic baud rate detection. This setting lets you determine the baud rate for communication between the lock's control electronics circuit board and the panel interface module by setting DIP switches on the panel interface circuit board. (See page 22.)
- Switch 8 is set to ON for locks with an insertion-type magnetic stripe card reader; it is set to OFF for locks with any other type of reader.

Installing the lock & through-bolt trim

14 Connect reader wire harness

1 For LH and LHRB doors

From the outside of the door, feed the reader wire harness connector through the door status switch & LH/LHRB reader wire hole.

For RH and RHRB doors

From the outside of the door, feed the reader wire harness connector through the field harness & RH/RHRB reader wire hole.

Caution: When routing the reader wire harness, make sure the reader wire harness is not routed across any sharp edges or over any surface that could damage its sleeving or wire insulation.

- 2 Temporarily rest the outside trim on the door by inserting the trim studs into the trim holes.
- 3 Connect the reader wire harness to the control electronics circuit board in the inside trim.

Caution: When connecting the reader wire harness, make sure:

- there are no loose wire connections where the wires are inserted into the reader wire connector
 - the reader wire harness connector is fully seated in its mating connector on the control electronics circuit board.
- 4 From the inside of the door, feed the solenoid and sensor wire harness from the control electronics circuit board, as well as the sensor wires and the solenoid wire, through the large opening in the inside trim.
 - 5 Insert the three bushings into the wire holes, as shown in Figure 14a and Figure 14b.

Note: The bushing used on the outside of the door should be inserted in the wire hole used in step 1.

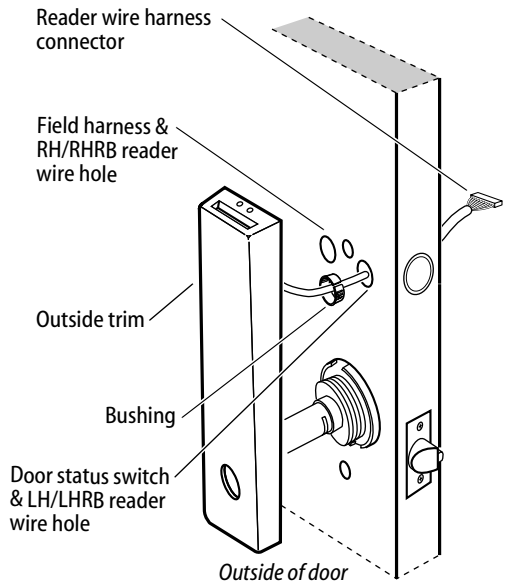

Figure 14a Feeding the reader wire harness connector through the wire hole

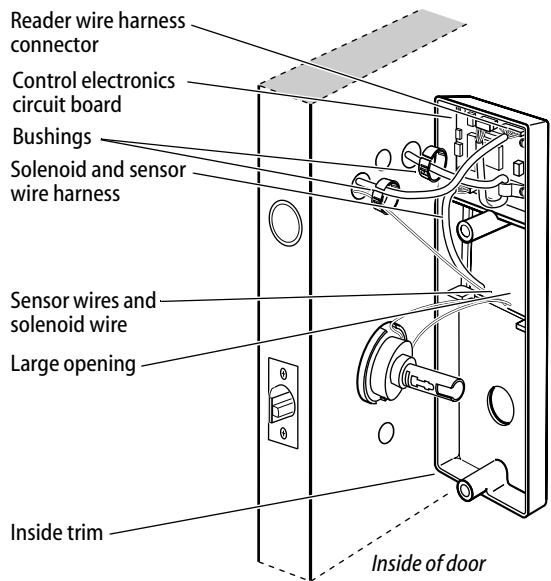

Figure 14b Connecting the reader wire harness to the control electronics circuit board

Installing the lock & through-bolt trim

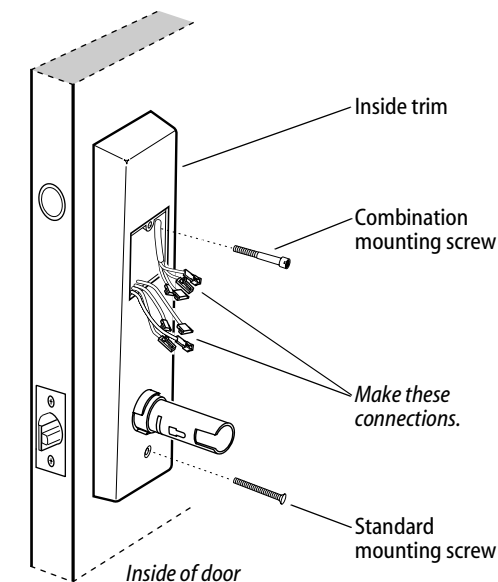

Figure 15 Securing the through-bolt trim and completing connections

15 Secure through-bolt trim and complete connections

- 1 Position the inside and outside trim onto the door.
- 2 **Making sure that the trim does not pinch the wires**, secure the trim to the door—but do not tighten. Use the combination mounting screw at the top trim hole and the standard mounting screw at the bottom trim hole.

Caution: When routing the solenoid and sensor wire harness, the sensor wires, and the solenoid wires, make sure the wires are not routed across any sharp edges or over any surface that could damage their sleeving or wire insulation.

- 3 Make the three (3) sensor connections and solenoid connection, and place the wires into the inside trim.

Wire connection	Color	No. of wires	No. of pins
Solenoid	Yellow	2	3
RQE	Brn/Org	2	3
Shorting connection	Purple	2	2
Door status sensor	White	2	2

Caution: When making the sensor connections and solenoid connection, make sure:

- there are no loose wire connections where the wires are inserted into the connectors
- the connectors are firmly mated.

Installing the lock & through-bolt trim

16 Install inside and outside knobs/levers

Note: To use a core and throw member from a manufacturer other than BEST with a 9KW Lock, see the Installation Instructions for 9K Non-interchangeable Cores & Throw Members (T56093). Skip task 16 and task 17.

1 For the inside and outside knobs

Push firmly on the knob until it is seated.

For the inside and outside levers

With the handle pointing toward the door hinges, push firmly on the lever until it is seated.

2 Tighten the trim mounting screws.

3 Turn the knobs/levers to check that they operate smoothly.

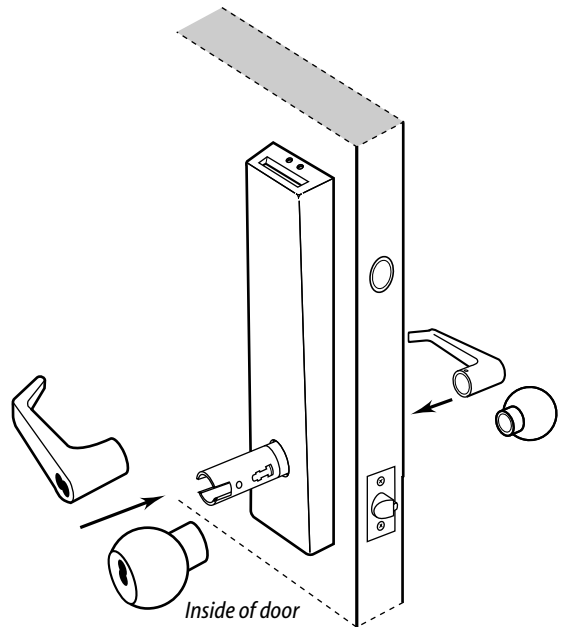

Figure 16 Installing the knobs/levers

Completing the installation at the door

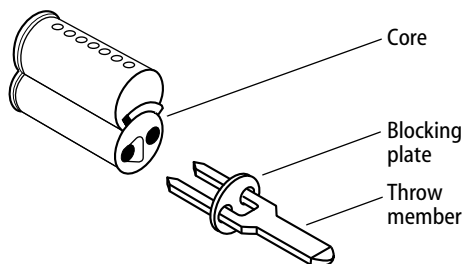

Figure 17a Installing the blocking plate and throw member

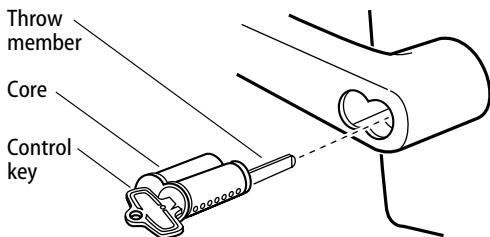

Figure 17b Installing the core

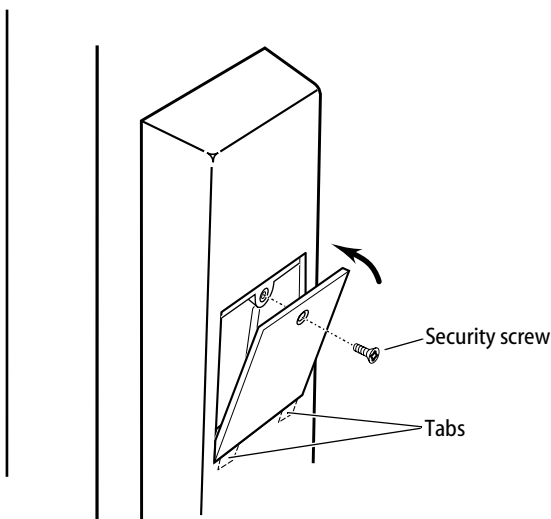

Figure 18 Installing the access door

17 Install core and throw member

- 1 Install the blocking plate onto the throw member.
Caution: You must use the blocking plate to prevent unauthorized access.
- 2 Insert the control key into the core and rotate the key 15 degrees to the right.
- 3 Insert the throw member into the core.
- 4 Insert the core and throw member into the knob/lever with the control key.
- 5 Rotate the control key 15 degrees to the left and withdraw the key.

Note: Be sure to insert the correct throw member into the core: 6-pin cores require the number "6" throw member; 7-pin cores require the number "7" throw member.

Caution: The control key can be used to remove cores and to access doors. Provide adequate security for the control key.

18 Install access door

- 1 **Making sure that the access door does not pinch any wires**, insert the tabs of the access door into its mating slots and swing the door closed.
- 2 Use a T15 TORX bit driver to secure the access door with the security screw. Tighten firmly.

Completing the installation at the door

19 Install the wire transfer hinge

- 1 Trim the four wires of the field wire harness, which you pulled through the hinge edge of the door in Task 7. Leave sufficient length to connect to the wire transfer hinge.
- 2 Splice the power and communication field wiring to the four pairs of leads on the frame side of the hinge, following the hinge manufacturer's instructions.
- 3 Splice the four field harness leads (listed in the table below) to the four pairs of leads on the door side of the hinge, matching each pair of leads to its corresponding field wire.

Wire	Color
Ground	Black
12 VDC	Red
Com+	Orange
Com–	Green

- 4 Insert the wires and splice connectors into the holes or pockets in the door and frame, being careful not to pinch the wires. Install the wire transfer hinge.

20 Install lock power supply (optional)

If you are providing a separate power supply for the lock instead of providing power via the panel interface module, connect the two power field wires (run from the wire transfer hinge) to the power supply. Make sure power (12 volts DC) and ground are connected properly.

Follow the instructions provided by the power supply manufacturer. Do not plug in the power supply yet.

Note: For specifications for the power supply, see Components checklist, on page 2.

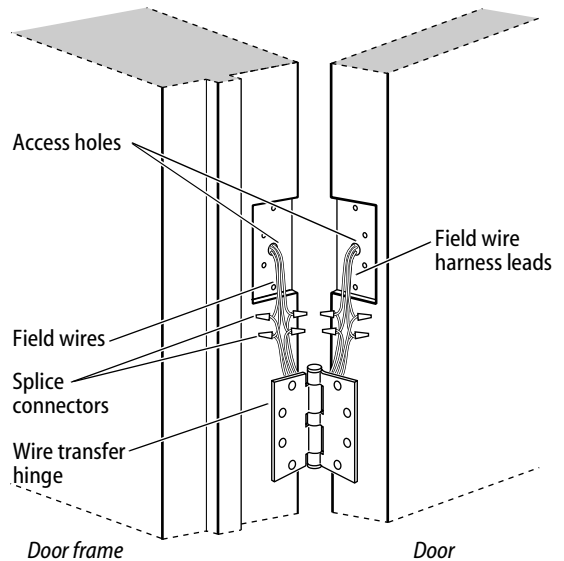
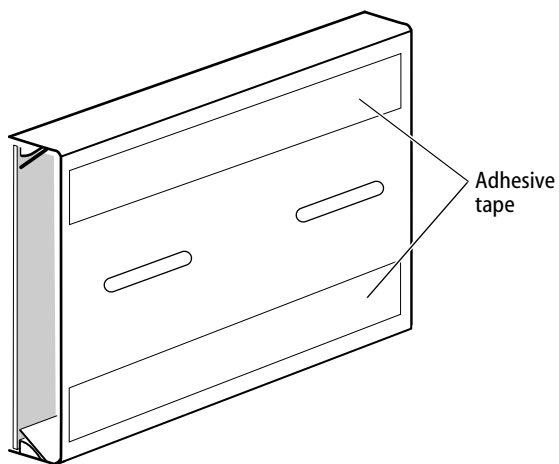

Figure 19 Installing the wire transfer hinge

Installing the panel interface module



21 Mount panel interface module

Peel the paper off the adhesive tape affixed to the back of the panel rail and press the panel rail into position.

Note: Mount the panel interface module in the enclosure with the access control panel/reader interface, if possible.

Figure 21 Mounting the panel interface module

Installing the panel interface module

22 Connect field wiring from wire transfer hinge to panel interface module

- 1 Connect the two communication field wires (run from the wire transfer hinge) to the COM+ and COM– terminals on the panel interface circuit board.

Note: The field wire harness leads, connected to the door side of the wire transfer hinge, are described in the table below.

Wire	Color
Ground	Black
12 VDC	Red
Com+	Orange
Com–	Green

- 2 If you are providing power to the lock through the panel interface module, connect the two power field wires (run from the wire transfer hinge) to the 12V and GND terminals on the panel interface circuit board.
- Note:** JP2 and JP3, shown in Figure 22a, are used for manufacturing purposes only.
- 3 Connect the RS-485 shield wire to one of the GND terminals on J1.

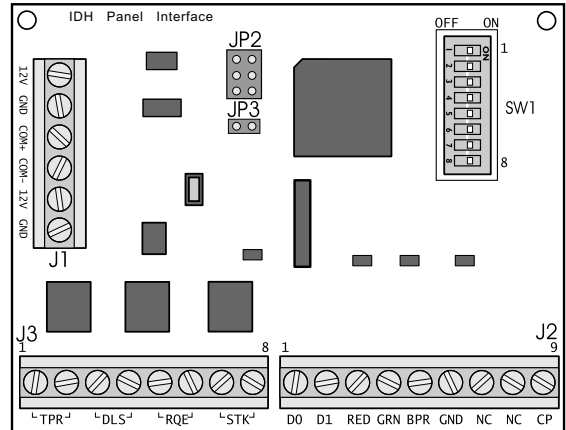

Figure 22a Panel interface circuit board

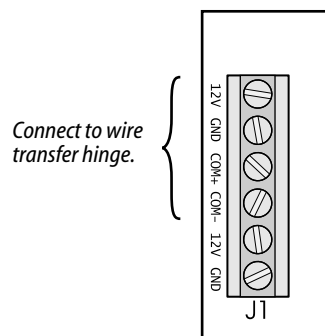
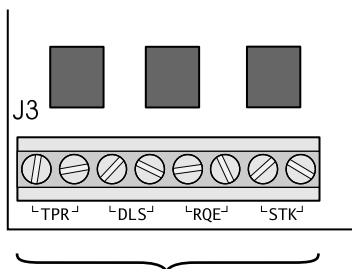

Figure 22b Connecting field wiring from the wire transfer hinge

Installing the panel interface module



Connect to access control panel/reader interface.

Figure 23a Connecting to the access control panel/reader interface

23 Connect panel interface module to access control panel/reader interface

With power removed from the panel interface circuit board and the access control panel/reader interface, connect the wiring between the panel interface circuit board and the access control panel/reader interface. Refer to the table below.

Connecting to the access control panel/reader interface

Terminals	Description	Related DIP switches
TPR (on J3) Communication tamper output	Switch-like output to the access control panel/reader interface that indicates the status of the communication connection between the panel interface circuit board and the lock's control electronics circuit board. By default, the output is closed to indicate communication is OK and open to indicate communication has been interrupted.	DIP switch 6 provides the ability to invert the signal. Set DIP switch 8 to ON.
DLS (on J3) Door status output	Switch-like output to the access control panel/reader interface that indicates the state of the lock's door status switch. By default, the output is closed to indicate the door status switch is closed. Note: The lock's door status switch is closed when the door is closed.	DIP switch 5 provides the ability to invert the signal. Set DIP switch 8 to ON.
RQE (on J3) Request-to-exit status output	Switch-like output to the access control panel/reader interface that indicates the status of the lock's RQE switch. By default, the output is closed to indicate the RQE switch is closed. Note: The lock's RQE switch is closed when the door knob/lever is turned, activating the switch.	DIP switch 4 provides the ability to invert the signal.
STK (on J3) Strike input	Input from the access control panel's/reader interface's strike relay, which provides the solenoid control signal. The access control panel/reader interface output usually has normally open (NO) and normally closed (NC) terminals, as well as a common terminal. The common and NO terminals should be connected to the two STK terminals on J3. To invert the operation, use the access control panel's/reader interface's common and NC terminals. The operation of the solenoid varies by lock function. See the <i>W Series Service Manual</i> (T60775).	None
D0, D1, & CP (on J2) Token data output	D0 is the Data 0 (Wiegand) or Strobe (ABA) token data output to the access control panel/reader interface. D1 is the Data 1 (Wiegand) or Data (ABA) output. D0 and D1 are capable of transmitting up to 250 feet. Note: The strobe signal is sometimes called 'clock'. CP is the Card Present (ABA) output. The card present signal is low (0 volts DC) during output of ABA token data.	None

continued

Installing the panel interface module

Terminals	Description	Related DIP switches								
RED & GRN (on J2) Reader LED input	<p>Input for the red and green LED control signal(s) from the access control panel/reader interface. This input is configured using DIP switch 1 for either one-wire LED operation or two-wire LED operation.</p> <p>Two-wire LED operation: Connect the access control panel's/reader interface's red LED output to the RED terminal and the access control panel's/reader interface's green LED output to the GRN terminal. The reader's red LED turns on when the access control panel/reader interface provides 0 volts DC to the input for the red LED. The reader's green LED turns on when the access control panel/reader interface provides 0 volts DC for the green LED.</p> <p>One-wire LED operation: Connect the access control panel's/reader interface's LED output to the RED terminal. The reader's LEDs are controlled as shown below.</p> <table border="1"> <thead> <tr> <th>Input signal</th> <th>LED response</th> </tr> </thead> <tbody> <tr> <td>0 volts DC</td> <td>Green LED ON</td> </tr> <tr> <td>5 volts DC</td> <td>Red LED ON</td> </tr> <tr> <td>Not driven</td> <td>Both LEDs OFF</td> </tr> </tbody> </table> <p>Note: The signals provided to the Reader LED input and the Sounder input must be greater than 3.5 volts DC to be interpreted as a 5 volts DC signal. Signals with voltage less than .8 volts DC are interpreted as 0 volts DC (connection to ground (GND)).</p>	Input signal	LED response	0 volts DC	Green LED ON	5 volts DC	Red LED ON	Not driven	Both LEDs OFF	DIP switch 1 configures this input for one-wire or two-wire operation.
Input signal	LED response									
0 volts DC	Green LED ON									
5 volts DC	Red LED ON									
Not driven	Both LEDs OFF									
BPR & GND (on J2) Sounder input	<p>Input for the sounder control signal from the access control panel/reader interface. By default, the lock's sounder turns on when the access control panel/reader interface closes the contact for the sounder, connecting the panel interface circuit board's BPR terminal to ground (GND).</p>	DIP switch 7 provides the ability to invert the interpretation of the sounder input signal.								
12V & GND (on J1) Power input	<p>Input for 12 volts DC at .1 amp power supply.</p> <p>Caution: To prevent damage and injury, connect the power supply after all other connections have been made.</p>	None								

Note: The two NC terminals on J2 are not used.

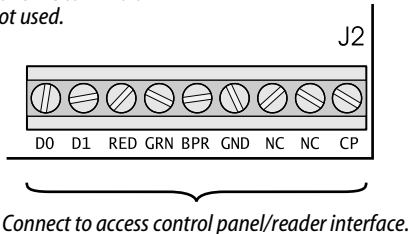

Figure 23b Connecting to the access control panel/reader interface

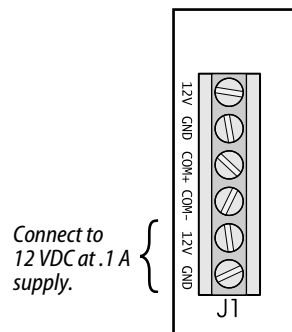

Figure 23c Connecting to the power supply

Installing the panel interface module

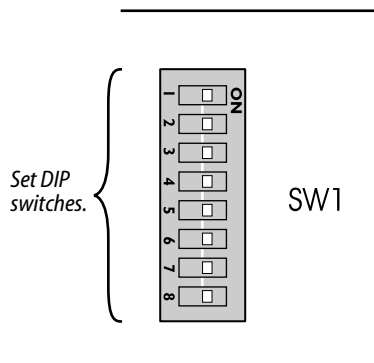

Figure 24 Setting DIP switches

24 Set panel interface module DIP switches

Set the DIP switches on the panel interface circuit board. Refer to the table below. Default settings are shown in boldface.

Note: DIP switch 8 is used in IDH Max Mortise installations. Leave this switch set to ON.

25 Set and connect power supply

- 1 Make sure that the output voltage of the power supply for the panel interface module and lock is set to 15 volts DC or lower.
- 2 Make the final power supply connections.
- 3 Adjust the power supply output voltage to 13.8 volts DC.

Setting DIP switches

Feature	Option	DIP Switch Setting
Reader LED input configuration Provides the ability to select between one-wire and two-wire LED operation for the reader LED input.	Two-wire operation	Switch 1–ON
	One-wire operation	Switch 1–OFF
Baud rate selection Provides the ability to select the baud rate for communication between the panel interface circuit board and the lock's control electronics circuit board. Note: To control the baud rate using DIP switches 2 and 3 on the panel interface circuit board, DIP switches 6 and 7 on the control electronics circuit board both must be set to ON (automatic baud rate detection).	38400 bps	Switch 2–OFF Switch 3–OFF
	19200 bps	Switch 2–ON Switch 3–OFF
	9600 bps	Switch 2–OFF Switch 3–ON
	2400 bps	Switch 2–ON Switch 3–ON
Request-to-exit (RQE) status output configuration Provides the ability to invert the request-to-exit (RQE) status signal. If DIP switch 4 is ON, the contact is closed when the door knob/lever is turned, activating the RQE switch.	Normally-open (NO)	Switch 4–ON
	Normally-closed (NC)	Switch 4–OFF
Door status output configuration Provides the ability to invert the signal for the door status output. If DIP switch 5 is ON, the contact is closed when the door is closed (the door status switch is closed).	Normally-closed (NC)	Switch 5–ON
	Normally-open (NO)	Switch 5–OFF
Communication tamper configuration Provides the ability to invert the signal for the communication tamper output. If DIP switch 6 is ON, the contact is closed when the communication connection between the panel interface circuit board and the lock's control electronics circuit board is OK.	Normally-closed (NC)	Switch 6–ON
	Normally-open (NO)	Switch 6–OFF
Sounder input configuration Provides the ability to invert the interpretation of the sounder input signal. The normal input configuration interprets a closed contact as sounder ON.	Normal input	Switch 7–ON
	Inverted input	Switch 7–OFF

Testing the installation

Perform the following steps to test the installation. Also, perform any standard testing recommended by the manufacturer of the access control panel. If you encounter problems, see *Troubleshooting the installation*, on page 24.

- 1 Check the control electronics' green status LED and the panel interface module's green status LED.
Both LEDs should be blinking, indicating that the communication connection between the panel interface circuit board and the lock's control electronics circuit board is OK.
- 2 After performing any necessary programming for the lock and putting the door in a locked mode, use a valid token to access the lock.
Confirm that the red reader LED, green reader LED, and sounder respond as expected.
The lock should allow access, verifying that the solenoid is working.
To check that the reader is working, view the lock's event history and verify that the information recorded for the token is correct.
- 3 Use an invalid token to attempt to access the lock.
Confirm that the red reader LED, green reader LED, and sounder respond as expected.
The lock should deny access.
- 4 With the door armed, attempt to exit through the door.
The request-to-exit (RQE) feature should let you exit without triggering an alarm by the access control panel.
- 5 Remove power from the lock and check whether the door remains locked or is unlocked.
Verify that the lock fails safe or secure, according to its function.
- 6 With the door armed, hold the door open. Hold a magnet against the edge of the door, over the door status sensor, until the access control panel sees the door as closed. Then remove the magnet.
Verify that the appropriate alarm response is triggered by the access control panel, indicating that the door status sensor is working.

Troubleshooting the installation

To troubleshoot installation problems, refer to the table below. For more information, refer to the *W Series Service Manual* (T60775) and to the documentation provided by the manufacturer of the access control panel/reader interface.

You notice . . .	Possible causes include . . .	You should . . .
<p>Control electronics' green status LED and panel interface module's green status LED are steadily on.</p> <p>Note: <i>You can check the control electronic's green status LED by removing the access door from the inside trim. You can see the reflection of the LED inside the upper-left corner of the trim.</i></p>	<p>Communication between the lock's control electronics circuit board and the panel interface circuit board has been interrupted.</p>	<p>Make sure DIP switches 6 and 7 on the lock's control electronics circuit board are both set to ON (automatic baud rate detection) or to the same positions as DIP switches 2 and 3 on the panel interface circuit board.</p> <p>Check the connections for all communication field wiring.</p> <p>Check the communication connections between the field wire harness and the wire transfer hinge.</p>
<p>Control electronics' green status LED is off.</p>	<p>Power is not being supplied to the lock.</p>	<p>Make sure that the lock's power supply is connected to electrical service.</p> <p>Check the connections for all power field wiring to the lock.</p> <p>Check the power connections between the field wire harness and the wire transfer hinge.</p>
<p>Panel interface module's green status LED is off.</p>	<p>Power is not being supplied to the panel interface module.</p>	<p>Check the connections for power wiring between the panel interface module and the access control panel (or other power source).</p>
<p>A 'door forced' alarm occurs when someone exits through the door.</p>	<p>RQE wiring and door status wiring is reversed between the panel interface module and the access control panel/reader interface.</p>	<p>Refer to <i>Connect panel interface module to access control panel/reader interface</i>, on page 20, and correct the wiring problem.</p>