

# Installation Instructions: C100 cylindrical lock

## 1 Technical specifications

### 1.1 Caution

**CAUTION:** If you use hollow metal doors, determine whether the doors are reinforced enough to support the lock. If door reinforcement is not adequate, consult the door manufacturer for information on proper reinforcement. Maximum door opening degree is 180°.

**CAUTION:** The deadlocking plunger of the latchbolt must not enter the strike plate opening. The plunger deadlocks the latchbolt and prevents forcing the latch when the door is closed. A gap of more than 1/8" may reduce security and/or cause improper operation of the latchbolt.

**CAUTION:** The control key can be used to remove cores and to access doors. Provide adequate security for the control key.

### 1.2 Tools recommended

Table 1

#2 and #3 Phillips screwdriver	2-1/8" (54 mm) hole saw
Tape measure	1" (25 mm) hole saw or drill bit
Hammer	Drill
1" (25 mm) wood chisel	Drill bit: 5/16" (8 mm) drill bit

### 1.3 Overview

Fig.1

Install the latch so that the bevel on the latchbolt faces the strike.

Adjust the outside rose assembly so that the chassis is centered in the door. Install the chassis from the outside of the door.

Install the inside liner, through-bolts, rose, lever and strike.

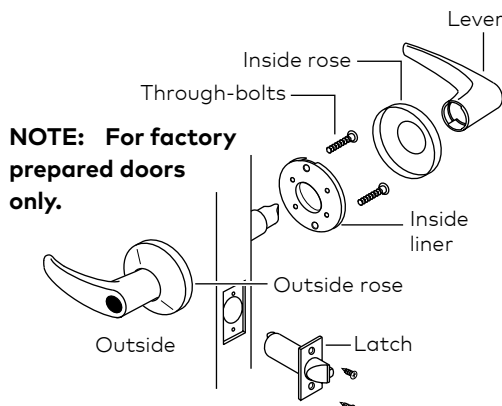

**NOTE: For factory prepared doors only.**

## 2 Installation instructions

### 2.1 Position template.

Fig.2

2.1.1 Fold the template and place it in position on the high edge of the door bevel.

2.1.2 Mark the drill points.

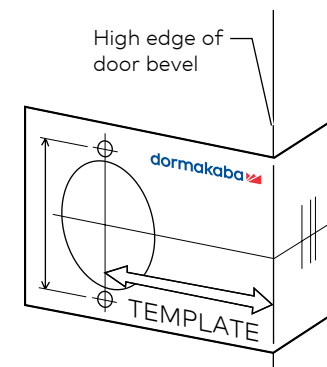

**NOTE: The suggested height from the floor to the centerline of the lock is 40 - 5/16" (1023 mm). If steel frames are used, the latch centerline must be in line with the center of the strike preparation.**

### 2.2 Bore two holes and install latch.

- 2.2.1 Bore a 2-1/8" (54 mm) diameter hole from both sides of the door to the center of the door.
- 2.2.2 Drill a 1" (25 mm) diameter hole from the edge of the door that intersects the 2-1/8" (54 mm) hole.
- 2.2.3 Mortise the door edge for the latch face.
- 2.2.4 Install the latch and check the door swing. Latch tabs should project into the 2-1/8" (54 mm) diameter hole.

### 2.4 Engage retractor in latch.

Fig.4

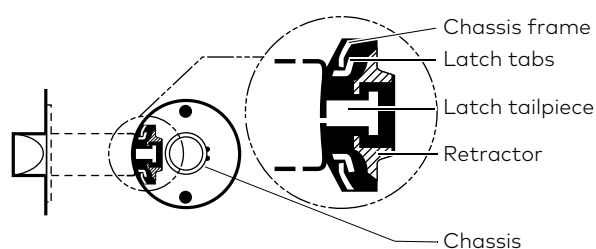

2.4.1 With the latch in place, install the chassis from the outside. Make sure the latch tabs engage the chassis frame and the latch tail piece engages the retractor.

### 2.3 How to adjust lockset to door thickness other than 1-3/4" (44 mm)

Fig.3a—Fig.3b

Fig.3a

**NOTE: This step is NOT necessary if installing the lockset on a 1-3/4" (44 mm) door.**

**NOTE: Locksets are preset at the factory for 1-3/4" (44 mm) thick doors.**

**NOTE: Locksets will fit doors 1-3/4" (44 mm) to 2-1/4" (57 mm) thick. (A spacer is available for 1-3/8" (35 mm) doors.) See Fig. 3a, the enlarged view, for the correct rose adjustment for these thicknesses.**

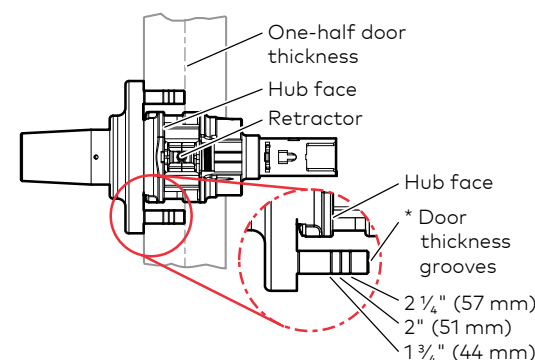
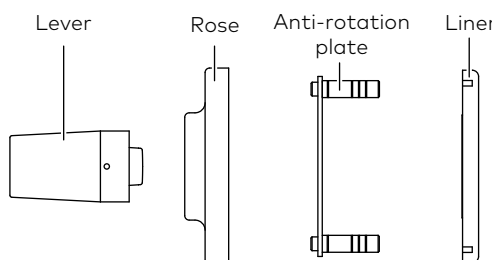

Fig.3b



**Follow these steps to adjust thickness:**

- 2.3.1 Remove the lever and the rose.
- 2.3.2 If the cylinder is in the lever, insert the key and rotate 90° to the right.
- 2.3.3 Depress the keeper and pull the lever off.
- 2.3.4 With the rose removed, slide the anti-rotation plate off.
- 2.3.5 Adjust for the door thickness by rotating the liner.
- 2.3.6 Check for the correct adjustment by sliding the anti-rotation plate back onto the liner and check the \*door thickness groove indicators. See Fig. 3a.

### 2.5 Install liner, through-bolts, rose and lever.

Fig.5

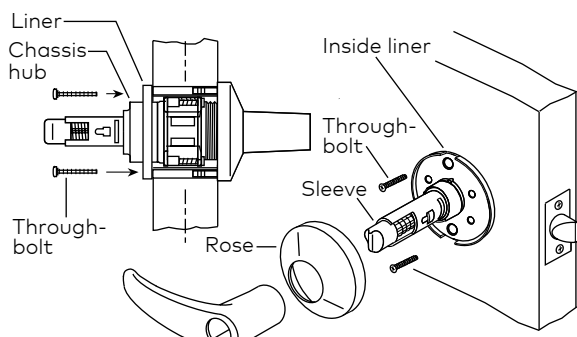

- 2.5.1 Align the holes in the liner with the holes prepared in the door.
  - 2.5.2 Install the through-bolts through the liner and the door in the top and bottom holes.
  - 2.5.3 Tighten the liner onto the door with the through-bolts.
  - 2.5.4 Slide the rose over the sleeve, then press the rose onto the liner. The rose should fit closely to the door surface.
  - 2.5.5 With the lever pointing toward the hinges, push the lever on firmly until seated.
- NOTE: For lead-lined locksets, slide the lead shield (not shown) over the sleeve and into the 2 -1/8" (54 mm).**

### 2.6 Install strike plate.

Fig.6

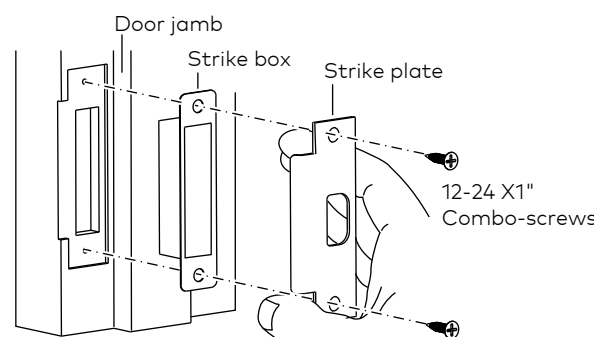

- 2.6.1 In alignment with the center of the latchbolt, mortise the door jamb to fit the strike box and the strike plate.
  - 2.6.2 Insert the strike box and secure the strike with the screws provided.
- CAUTION:** The deadlocking plunger of the latchbolt must not enter the strike plate opening. The plunger deadlocks the latchbolt and prevents forcing the latch when the door is closed. A gap of more than 1/8" (3 mm) may reduce security and/or cause improper operation of the latchbolt.

## 3 Instructions - C100 key-in-lever cylinders

### 3.1 Assemble and install OEM key-in-lever cylinder.

Fig.7a—Fig.7c

**NOTE:** The following steps, 3.1.1—3.1.2, are NOT necessary if the cylinder is installed at the factory.

These instructions describe how to install a key-in-lever cylinder into a C100 dormakaba lever handle. Use these instructions only after completing the installation of the cylindrical chassis.

The C100 key-in-lever cylinder cylindrical lock accepts the following keying system adaptations:

- Schlage, Corbin, Sargent, Yale, Medeco

**NOTE:** For Schlage or Corbin keying systems and key-in-lever cylinders provided by dormakaba.

Follow these steps to install a Schlage or Corbin key-in-lever cylinder into the dormakaba C100 lever handle, as well as the key-in-lever cylinder provided by dormakaba:

- 3.1.1 Install the dormakaba adaptation throw member.
- 3.1.2 Install the throw member and the cylinder into the handle. See Fig. 7a.

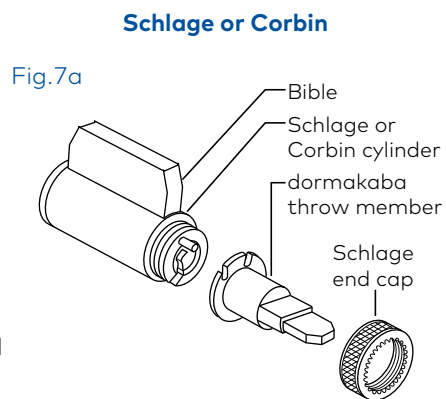

**NOTE:** For Sargent or Yale keying systems

Follow these steps to install a Sargent or Yale key-in-lever cylinder into the dormakaba C100 lever handle:

**NOTE:** For Yale cylinders install the throw member so that the countersunk hole is nearest the pin.

- 3.1.1 Install the dormakaba adaptation throw member.
- 3.1.2 Install the throw member and the cylinder into the handle. See Fig. 7b.

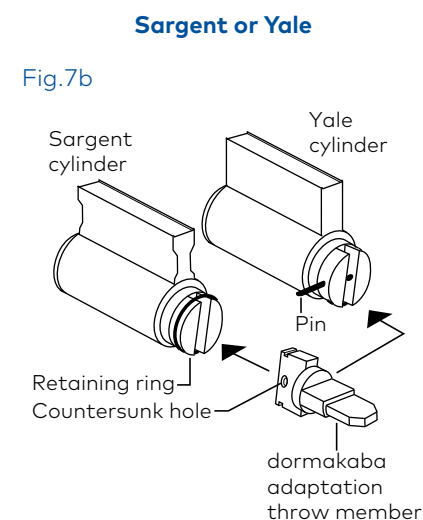

**NOTE:** For Medeco keying systems

Follow these steps to install a Medeco key-in-lever cylinder into the dormakaba C100 lever handle:

**Two adaptation throw members exist:**  
**Gold:** Use with Medeco-style levers.  
**Silver:** Use with Sargent-style levers.

- 3.1.1 Install the dormakaba adaptation throw member.
- 3.1.2 Install the throw member and the cylinder into the handle. See Fig. 7c.

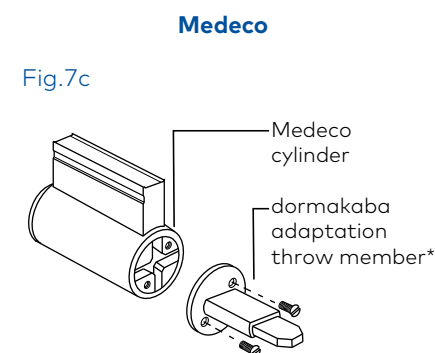

### 3.2 Install lever insert and support ring.

Fig.8a—Fig.8b

**NOTE:** The support ring is necessary to completely secure the lever.

Fig.8a

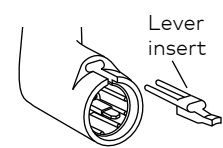

- 3.2.1 Install the lever insert.

Fig.8b

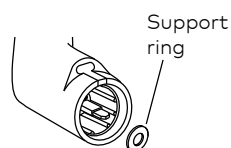

- 3.2.2 Install the support ring.

### 3.3 Orient locking cam.

Fig.9

- 3.3.1 Carefully turn the locking cam using a Phillips-head screwdriver to the left until it stops.

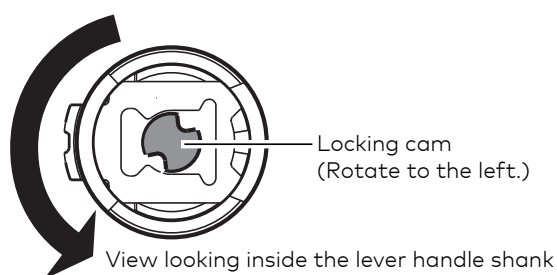

### 3.4 Install lever handle.

- 3.4.1 Insert the key into the cylinder.
- 3.4.2 Turn the key 90° to the left.
- 3.4.3 Insert the lever handle until seated.
- 3.4.4 Remove the key from the cylinder.
- 3.4.5 For double-keyed units, repeat steps 1–4.

## 4 Instructions - C100 BEST interchangeable cores

### 4.1 Assemble and install optional BEST I/C core.

Fig.10

**CAUTION:** The control key can be used to remove cores and to access doors. Provide adequate security for the control key.

**NOTE:** For 6-pin core users only: Slide the spacer — supplied with your 6-pin cores — over the 7-pin throw member.

**NOTE:** For "85" functions only: Install the proper throw member.

**NOTE:** If you have ordered 6-pin cores, you will get one spacer per core with your order. Spacers are not supplied with the locks.

- 4.1.1 Install the throw member into the back of the core.
- 4.1.2 Insert the control key into the core and rotate the key 15° to the right.
- 4.1.3 Insert the core and throw member into the lever with the control key.
- 4.1.4 Rotate the control key 15° to the left and withdraw the key.

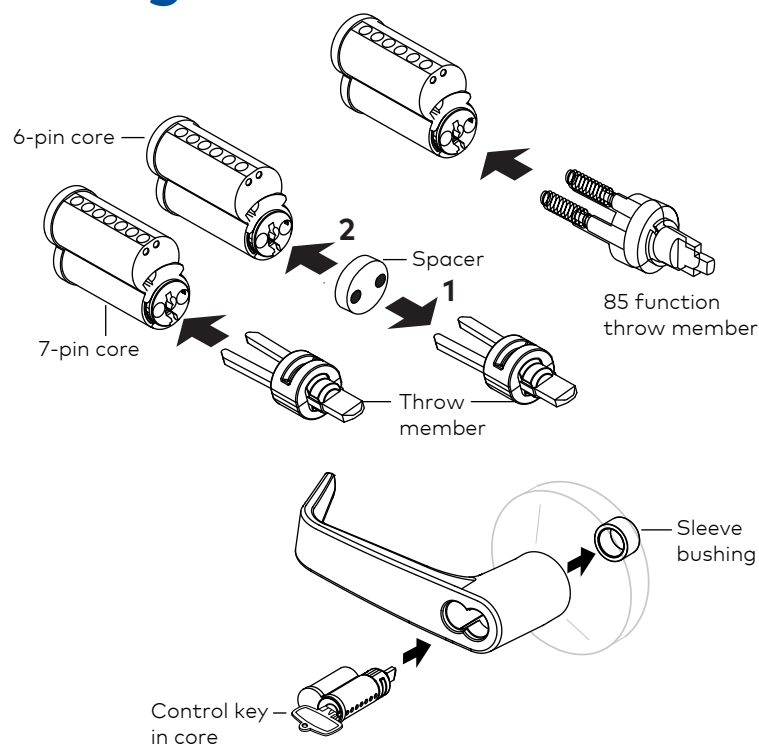

For online instructions visit:  
<https://dhwsupport.dormakaba.com/hc/en-us>  
 For assistance or warranty information:  
 Call 1-800-392-5209 or visit  
<https://dhwsupport.dormakaba.com/hc/en-us>