

Core and Key

SERVICE MANUAL

CORES C & KEYS A SERIES

CREDITS/COPYRIGHT

Copyright ©2022 dormakaba USA Inc. All rights reserved.

Information in this document is subject to change without notice and does not represent a commitment on the part of dormakaba USA Inc. The software described in this document are furnished under a license agreement or nondisclosure agreement.

This publication is intended to be an accurate description and set of instructions pertaining to its subject matter. However, as with any publication of this complexity, errors or omissions are possible. Please call dormakaba USA Inc. at 1-800-392-5209 if you see any errors or have any questions. No part of this manual and/or databases may be reproduced or transmitted in any form or by any means, electronic or mechanical, including photocopying, recording, or information storage and retrieval systems, for any purpose, without the express written permission of dormakaba USA Inc.

This document is distributed as is, without warranty of any kind, either express or implied, respecting the contents of this book, including but not limited to implied warranties for the publication's quality, performance, merchantability, or fitness for any particular purpose. Neither dormakaba USA Inc., nor its dealers or distributors shall be liable to the user or any other person or entity with respect to any liability, loss, or damage caused or alleged to be caused directly or indirectly by this publication.

Written and designed by:
dormakaba USA Inc.
6161 East 75th Street
Indianapolis, IN 46250

T35527_Rev C B1823547 ER7991-6 April 2022

CONTENTS

FIGURES v

GETTING STARTED 1-1

- Introduction 1-1
- Product family diagram 1-2
- Certifications and standards 1-2
- Documentation package 1-3
- Technical support 1-3
 - Support services 1-3
 - Telephone technical support 1-3

PARTS 2-1

- Overview of the BEST core 2-2
 - Exploded view of the 1C 7-pin core 2-2
 - Core descriptions and figures 2-3
 - Segments, springs, and caps 2-6
 - UL application of the 5C core 2-7
 - Dust cover option 2-8
- Overview of the BEST key 2-9
 - Diagram of the 1A key 2-9
- Key types 2-9
- Tools 2-12

SERVICING AND TROUBLESHOOTING 3-1

- Placing pin segments, springs, and caps in a core 3-2
 - Overview of how a key works in the core 3-2
 - Loading the core 3-3
 - Checking a core for proper operation 3-7
- Replacing a dust cover assembly 3-8

Contents

Lubricating a core 3-9

Thawing a core 3-10

Troubleshooting 3-11

GLOSSARY A-1

INDEX B-1

FIGURES

GETTING STARTED

Core and key product family 1-2

PARTS

1C 7-pin core 2-2

Cross section view of a core 2-2

Segments, springs, and caps 2-6

Loading the 5C core for the 1E7K4 cylinder 2-7

Dust cover components 2-8

Standard key features 2-9

Tools used for servicing cores and keys 2-12

Stamping tools 2-14

Lubrication items 2-15

SERVICING AND TROUBLESHOOTING

Cross section of a core showing control and operating shearlines 3-2

Identifying the parts of the core 3-3

Pushing the control lug into the thrown position 3-3

Inserting the segments into the barrel 3-4

Inserting the stop pin and core into the capping block 3-5

Seating the cap in the barrel 3-5

Dust cover assembly in position 3-8

Using the ejector pin to mark the segment stack height 3-14

Using the key cut indicator 3-15

1

GETTING STARTED

INTRODUCTION

The *Core and Key Service Manual* contains essential information to help you maintain your BEST cores and keys.

PRODUCT FAMILY DIAGRAM

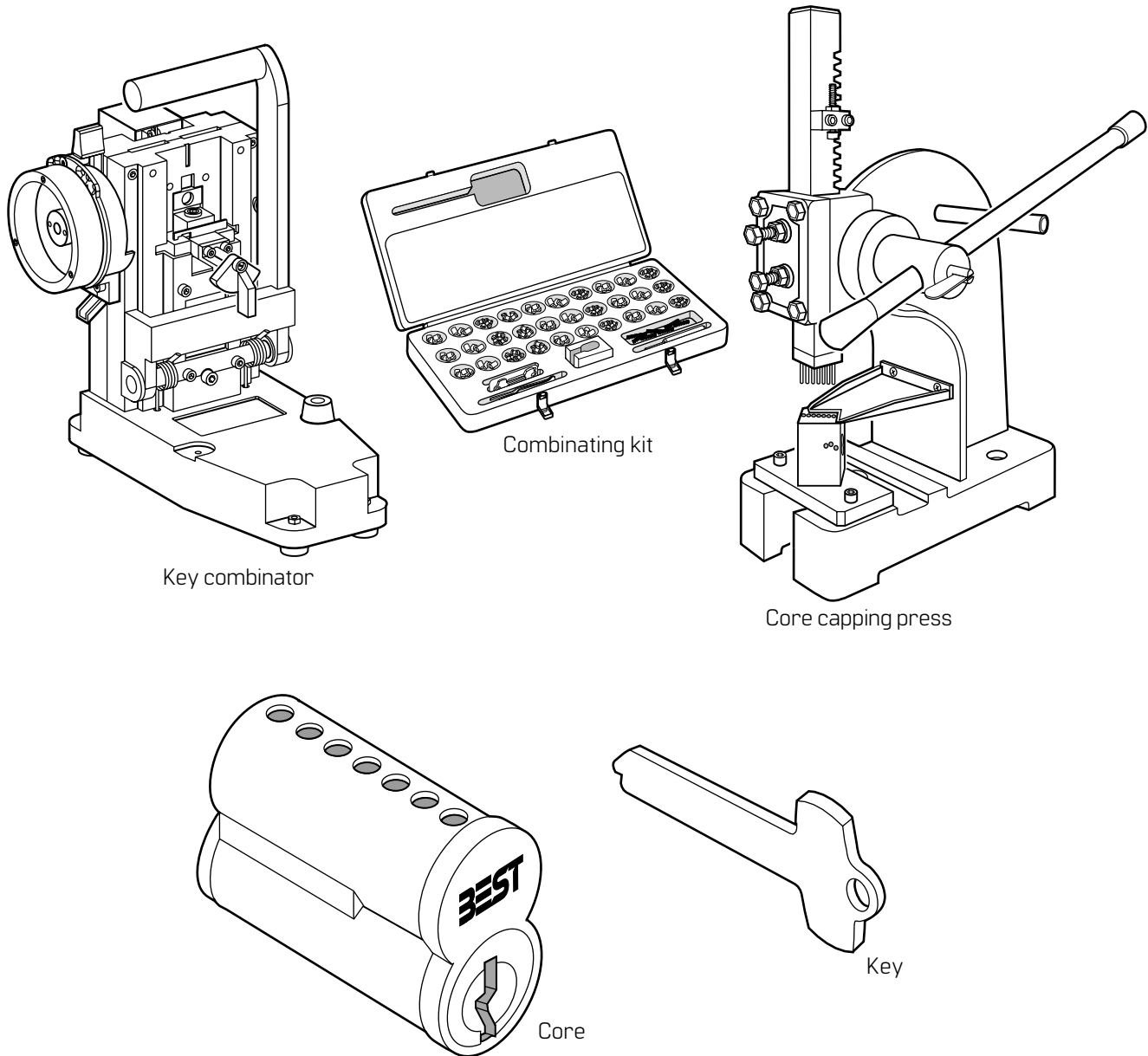

Figure 1.1 Core and key product family

CERTIFICATIONS AND STANDARDS

- BEST cores conform to ANSI/BHMA 156.5.

DOCUMENTATION PACKAGE

The following documentation is available to help you with the installation, operation, and maintenance of your BEST cores and keys along with associated service equipment. These documents also can be ordered separately from the product.

Document Title	Doc. No.
<i>Installation Instructions for Construction Cores Operating</i>	T35526
<i>Instructions for AD432 Key Combinator Operating</i>	T35531
<i>Instructions for AD433 Key Combinator Operating</i>	T35529
<i>Instructions for AD502 Micrometer Key Gauge Key</i>	T35530
<i>Combinator Service Manual</i>	T35532
<i>A2 System Service Manual</i>	T35534
<i>A3 System Service Manual</i>	T35535
<i>A4 System Service Manual</i>	T35536

TECHNICAL SUPPORT

Support services

When you have a problem with a BEST core or key, your first resource for help is the *Core and Key Service Manual*. If you cannot find a satisfactory answer, contact your local dormakaba Representative.

Telephone technical support

A factory-trained Certified Product Specialist [CPS] is available in your area whenever you need help. Before you call, however, please make sure that the product is in your immediate vicinity, and that you are prepared to give the following information:

- what happened and what you were doing when the problem arose
- what you have done so far to correct the problem.

dormakaba USA Inc. representatives provide telephone technical support for all B Series products. You may locate the representative nearest you by calling (800) 392-5209 Monday through Friday, between 8:00 a.m. and 5:00 p.m. eastern standard time; or visit the web page, <https://dhwsupport.dormakaba.com/hc/en-us>.

dormakaba holds training sessions for its customers. The seminars are specifically designed for dormakaba end-users who have a registered a dormakaba [BEST branded product] masterkeyed system and registered a dormakaba [BEST branded product] security equipment. If you are interested, you may contact your local dormakaba representative for details.

2

PARTS

The following pages contain descriptions and figures of cores, keys, and tools for servicing them.

OVERVIEW OF THE BEST CORE

Exploded view of the IC 7-pin core

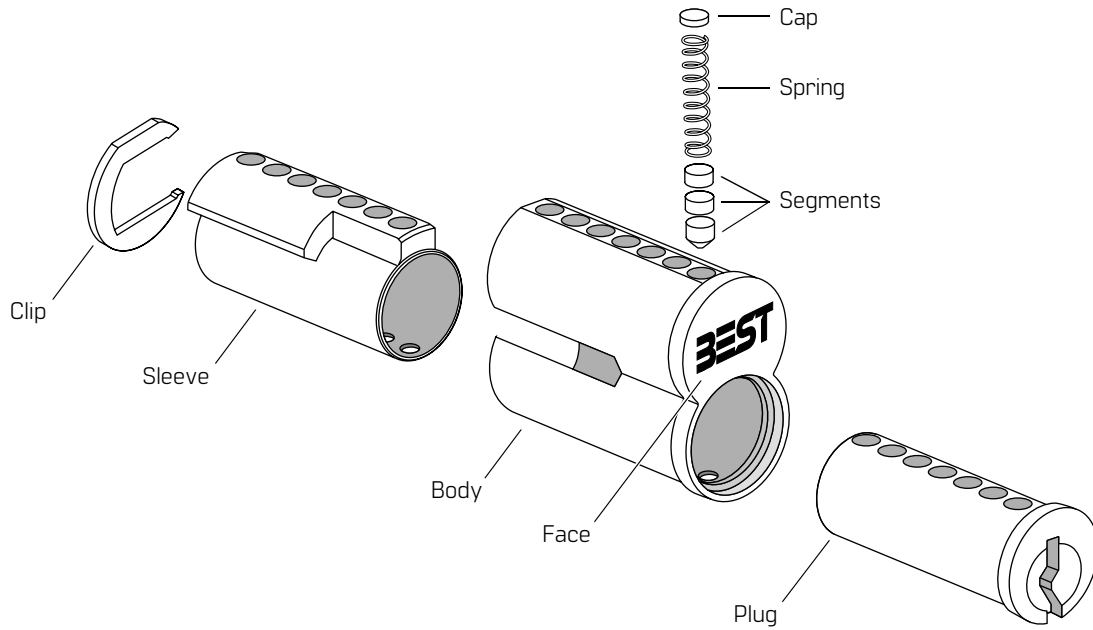

Figure 2.1 IC 7-pin core

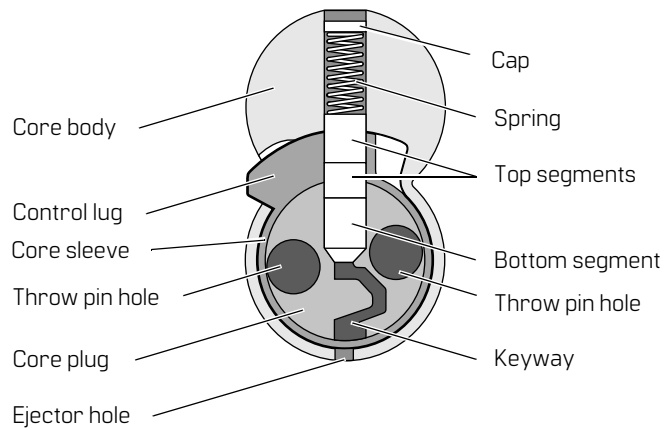

Figure 2.2 Cross section view of a core

Core descriptions and figures

Use the following table to help you order a BEST core.

1C	7	A	1		606
Core type	Core size	Keyway	Combining code	Options	Standard finishes
1C–Standard	5–5-pin	Designate specific keyway (A, E, etc.)	1–Uncombined 2–Combined	Blank–Standard	605–Bright brass
1CP–Premium key system	(1C core only)			B–Pick & drill resistant	606–Satin brass
1CCOBP–Plastic construction core	6–6-pin (1C and 2C cores only)			C–Dust cover	612–Satin bronze
2C–Extended plug				D–Drill resistant	613–Oxidized satin bronze, oil rubbed
3C–European 5C–High security 6C–Core for 4S	7–7-pin			K–Key trap	625–Bright chromium plated
				P–Pick resistant	626–Satin chromium plated
				S–Set screw (6C only)	
				T–Key retained operation (6C only)	
				W–Wear resistant	

See [Table 2.3](#) for more information.

See [Table 2.4](#) for more information.

Table 2.3 Core type descriptions

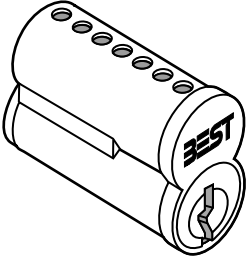
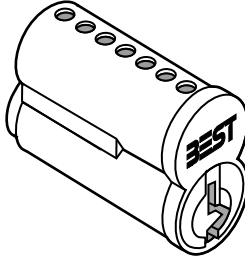
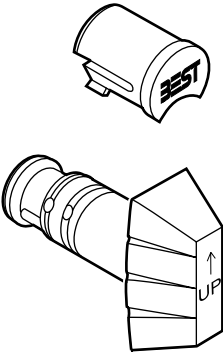
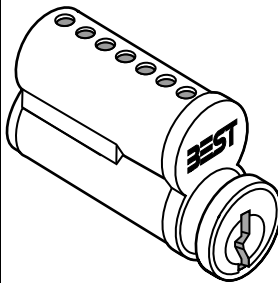
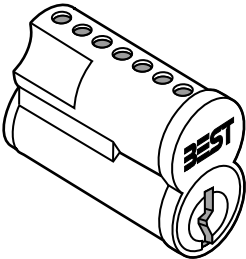
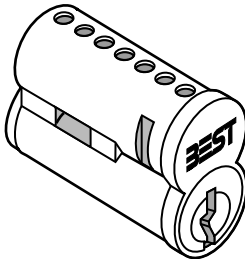
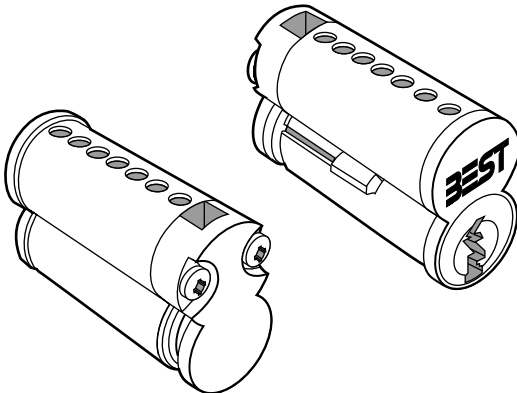
<p>1C core</p>  <p>Standard interchangeable core.</p>	<p>1CP core</p>  <p>Premium interchangeable core.</p>
<p>1CCOBP core</p>  <p>Black plastic, non-keyed construction core used to secure interior doors at a construction site.</p>	<p>2C core</p>  <p>Interchangeable core used in the 8L mailbox lock.</p>
<p>3C core</p>  <p>Interchangeable core used with the 8E European lock adaptation.</p>	<p>5C core</p>  <p>High security interchangeable core used in the 1E cylinder for mortise applications.</p>
<p>6C core^a</p>  <p>Interchangeable core used in the 4S sliding door cylinder lock.</p> <p>Regardless of the cores's finish, the lost-motion assembly on the back of the core has a stainless steel finish.</p>	

a. The set screw style is not shown.

Table 2.4 Core options

Option	Nomen- clature	Description
Pick & drill resistant	B	Provides enhanced resistance to picking and drilling the core. Hardened ball bearings are used in the throw pin holes and hardened stainless steel segments are used as the top and bottom segments in the first two barrels of the core. Spooled segments are used as the top and bottom segments in each remaining barrel of the core.
Dust cover	C	Prevents the keyway from accumulating dust and dirt. Stainless steel spring-loaded dust cover is installed over the keyway. For part numbers, see page 2–8 . Note: If the core is housed in a cylinder, use the cylinder dust cover instead of the core dust cover for maximum protection.
Drill resistant	D	Provides enhanced resistance to drilling the core. Hardened ball bearings are used in the throw pin holes and hardened stainless steel segments are used as the top and bottom segments in the first two barrels of the core.
Key trap	K	Eliminates a key from the system by trapping it in the core. This option is useful if a key has been lost, or if someone has a key and will not give it back. When the key is inserted into the core and is turned, the key is trapped in the core. The key cannot be returned vertically nor withdrawn from the core. The core and trapped key must be drilled out of the lock. This special core is modified at the factory to match the key that you want to trap.
Pick resistant	P	Provides enhanced resistance to picking the core. Spooled segments are used as the top and bottom segments in each barrel of the core.
Set screw (for 6C core only)	S	Alternate design of the 6C core used in the 4S sliding door cylinder lock. A set screw is used to hold the core in the lock.
Key retained (for 6C core only)	T	Provides an extra measure of security by trapping the key in the core while the core is unlocked. The core stays locked unless the key is left in it. A sleeve without a slot is used to hold the key in the core.
Wear resistant	W	Provides longer life for cores in high traffic areas. Hardened stainless steel segments are used as the bottom segments in each barrel of the core.

Segments, springs, and caps

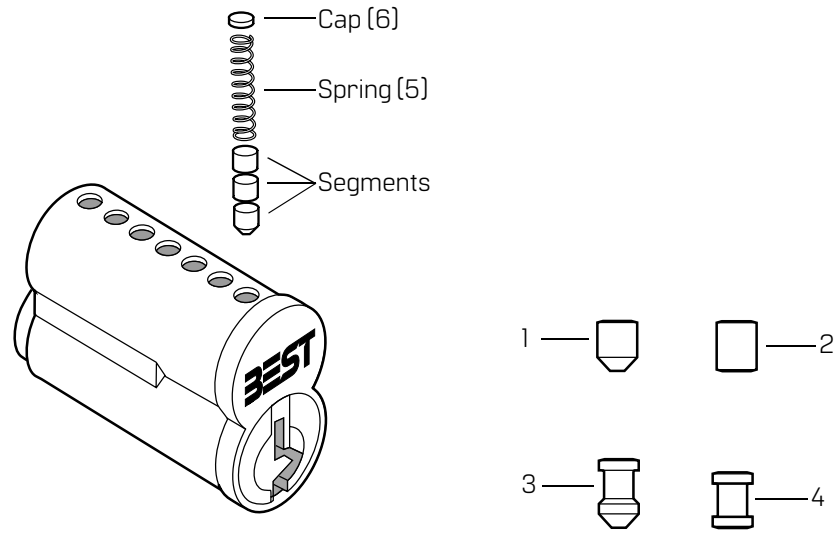

Figure 2.5 Segments, springs, and caps

Item	System	Nomenclature	Description
1	A2	A	Standard beveled (bottom) segment. Available in nickel silver or hardened stainless steel.
	A3	C	
	A4	E	
2	A2	B	Standard flat (top) segment. Available in brass or hardened stainless steel.
	A3	D	
	A4	F	
3	A2	A	Spooled beveled (bottom) segment. Available in nickel silver.
	A3	C	
	A4	E	
4	A2	B	Spooled flat (top) segment. Available in brass.
	A3	D	
	A4	F	
5		22S	Spring (500 per package)
		22S20M	Spring (20,000 per package)
6		21C	Cap (500 per package)

Note: For more information, see the *A2 System Service Manual* (T35534), the *A3 System Service Manual* (T35535), and the *A4 System Service Manual* (T35536).

UL application of the 5C core

The 5C core is used in the 1E7J4 and 1E7K4 high-security cylinders. It is also used in the 71B, 81B, and 91B high-security padlocks.

To have the 1E7J4 cylinder qualify for the Underwriters Laboratories (UL) high-security rating, the 5C core must be combined and loaded at the factory. Likewise, any core that needs to be recombined and reloaded must be sent to the factory. If the 5C core is combined and loaded outside of the factory, the cylinder no longer qualifies for the UL rating, and the UL-stamped cylinder faceplate cannot be used.

The 1E7K4 cylinder does not have the UL-stamped faceplate. You can combine and load the 5C core to be used in a 1E7K4 cylinder. For high-security applications, combine and load the 5C core as you would any other core *with the following exceptions*:

- Use hardened stainless steel segments in barrels six and seven.
- Use spooled segments in all remaining barrels, except where 6B segments are required. In those cases, use standard 6B segments.

Note: 5C cores used in 71B, 81B, and 91B padlocks do not need to be combined and loaded as described above to provide high-security features.

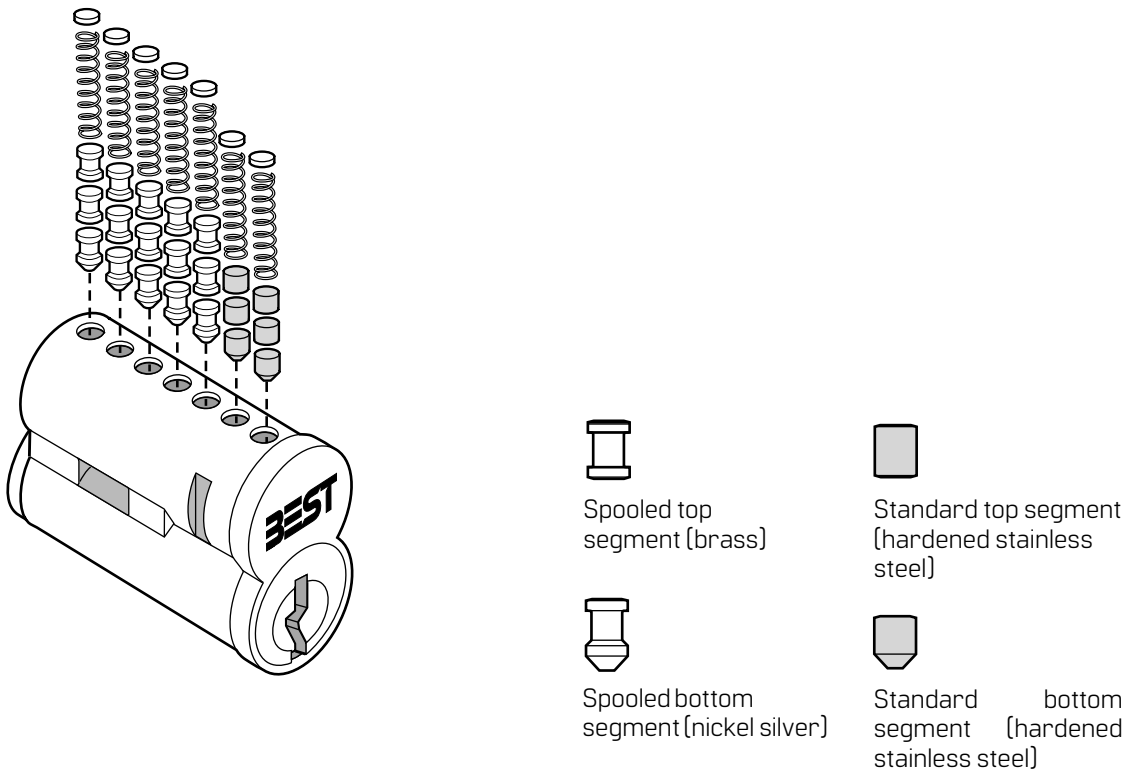

Figure 2.6 Loading the 5C core for the 1E7K4 cylinder

Dust cover option

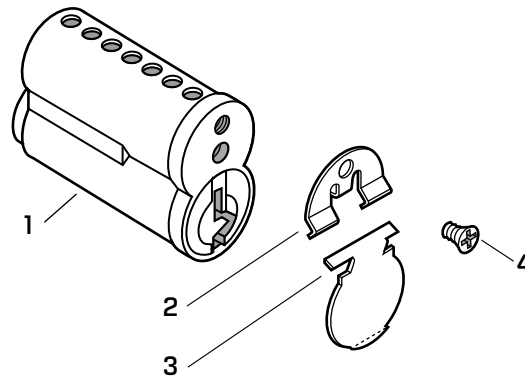

Figure 2.7 Dust cover components

Item	Part No.	Description
1	A40305	Core
2	B26247	Dust cover hinge
3	A00127	Dust cover
4	A40083	#4-40 Pan head screw

OVERVIEW OF THE BEST KEY

Diagram of the 1A key

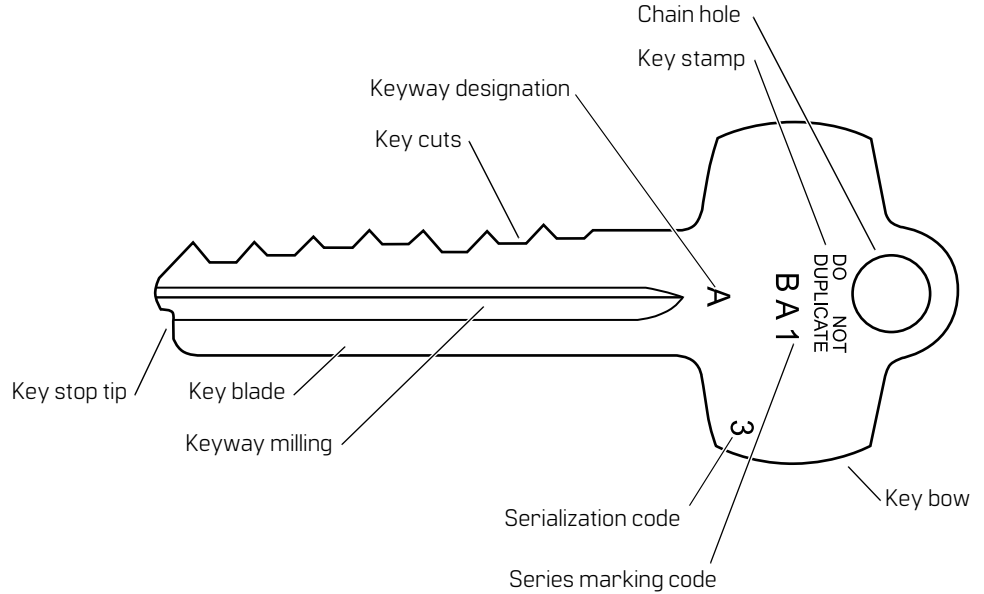

Figure 2.8 Standard key features

Key types

1A	1	A	1	Key stamp ^a	Options	
Key shape (bow)	Key type	Keyway	Cut code			
1A–Standard	0–Blockout blade	Designate specific keyway or keyways if multiple milling ^b is required. (A, E, etc.)	1–Blank	KS654 & KS292–Standard embossing supplied if not designated. KS567–Premium (For 1AP only) KS594–Premium (For 1AP only) Specify KS#–Price for most custom design stamps available upon request.	B–Long blade ^b	
1AP–Premium (PKS)	1–Operating or blank		2–Cut		H–No hole (For 2A only)	
2A–Round bow	2–Control				N–Long nose ^b	
3A–Rectangular bow	3–Master				NKW–No keyway designation (Standard for 1AP)	
4A–Access bow	4–Submaster				P–Plastic insert (For 4A only)	
9A–Extractor keys and blockout blades.	5–Grandmaster				S–Key serialization	
9AP–Blockout blade (Premium)	9–Extractor key					
See Table 2.9 for more information.					See Table 2.10 for more information.	

a. You must designate a front key stamp and a back key stamp. There is no standard back key stamp for the Premium key.

b. Not available for 1AP keys.

Table 2.9 Key type descriptions



<p>1A key</p>  <p>Standard</p> <p>Long blade</p> <p>Long nose</p> <p>Standard key with the standard bow.</p>	<p>1AP key</p>  <p>Premium</p> <p>Premium key used with the ICP core.</p>
<p>2A key</p>  <p>Round bow</p> <p>Round bow without key chain hole</p> <p>Standard key with the round bow.</p>	<p>3A key</p>  <p>Rectangular bow</p> <p>Standard key with a rectangular bow.</p>
<p>4A key</p>  <p>Access bow with window</p> <p>Access bow</p> <p>Standard key with the large offset bow. Comes with or without a window and plastic insert. Used with hotel locks.</p>	<p>9A blackout blade and 9A9 blackout blade extractor</p>  <p>9A blackout blade</p> <p>9A9 blackout blade extractor key (included with 9A blade)</p> <p>The 9A blackout blade slides in a keyway and blocks out other keys. 9A9 is a special tool used to remove the 9A blackout blade segment.</p>

Table 2.10 Key stamp descriptions

<p>KS654 key stamp</p>  <p>Standard front key stamp for full embossing.</p>	<p>KS292 key stamp</p>  <p>Standard back key stamp for embossing.</p>
<p>KS567 key stamp</p>  <p>Standard front key stamp for the IAP premium key.^a</p>	<p>KS594 key stamp</p>  <p>Alternative front key stamp for the IAP premium key.^a</p>

a. There is no standard back key stamp for the IAP premium key.

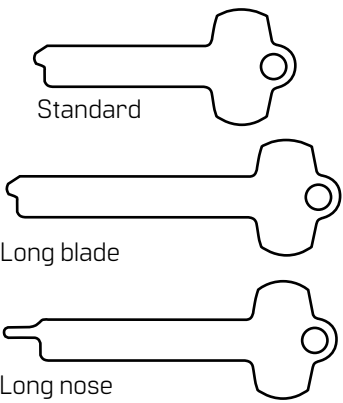
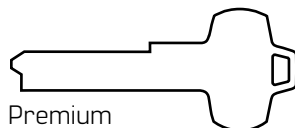
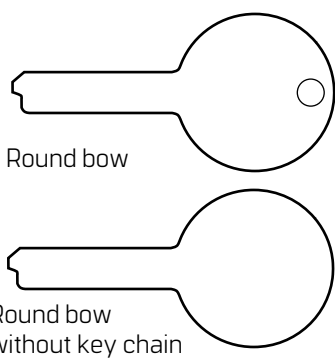
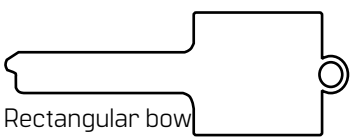
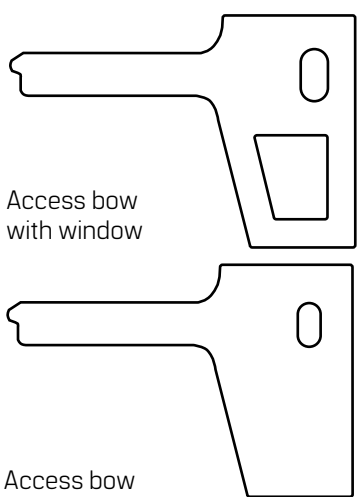
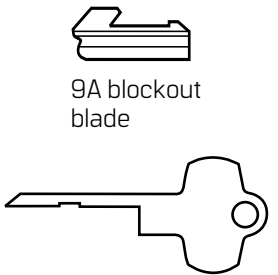
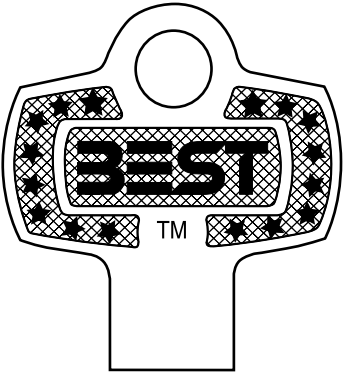
Note: Custom stamps are available upon request.

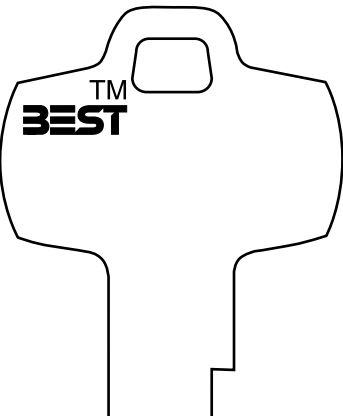
TOOLS

The following tools are used for servicing cores and keys.

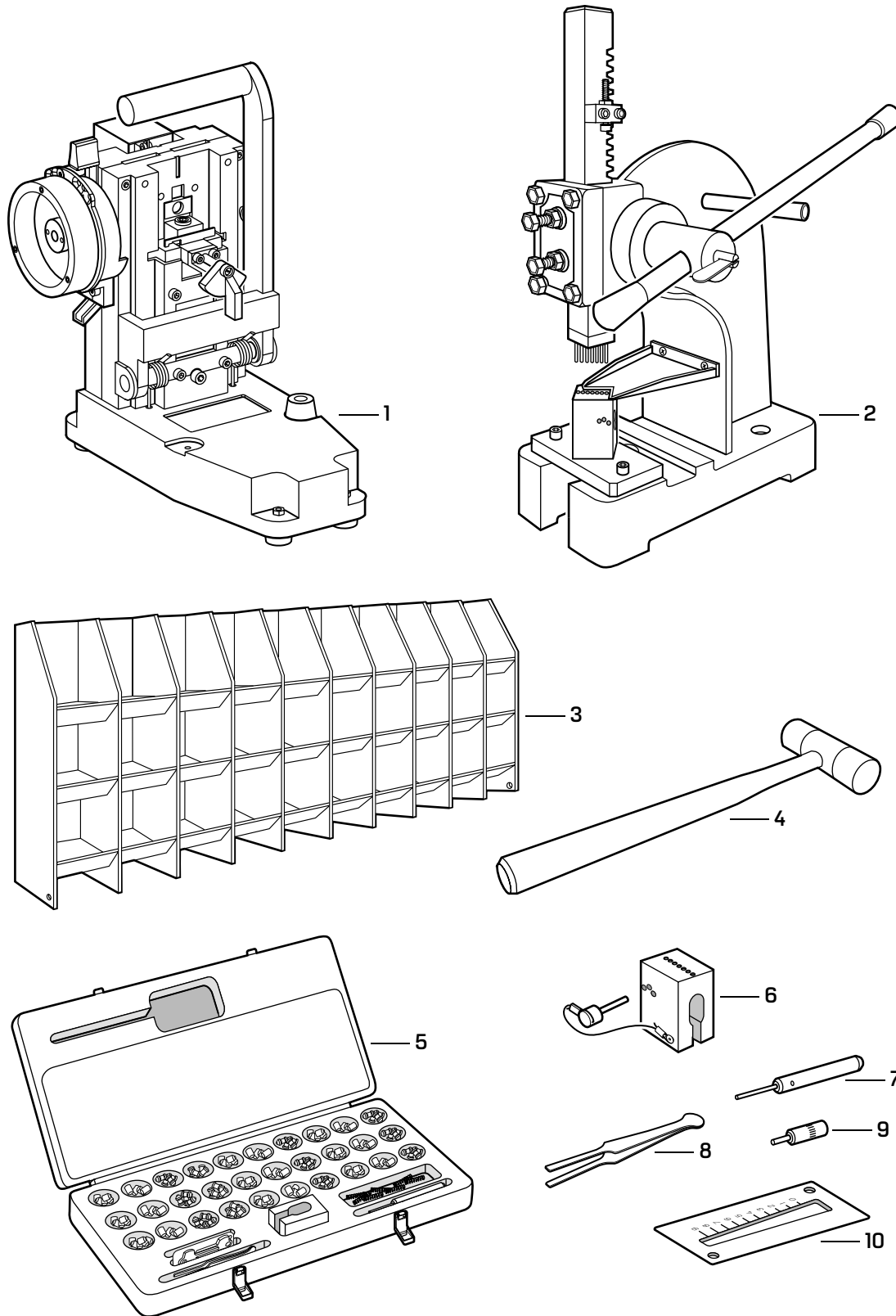

Figure 2.11 Tools used for servicing cores and keys

Item	Nomenclature	Description
1	AD433	Key combinator ^{a, b}
2	CD517	Core capping press
3	CD433	Combining bin
4	DD550	Combining hammer
not shown	DD551	Plastic heads for combining hammer
5	CD431	Complete combining kit ^b
6	CD540	Capping block ^c
7	CD548	Ejector pin ^c
8	CD549	Tweezers ^c
9	CD547	Hand capping pin ^c
10	AD501	Key cut indicator ^{b, c}

a. For other parts associated with the key combinator, see the *Key Combinator Service Manual*.

b. Specify A2, A3, or A4 Keying System when ordering.

c. Also is included in the complete combining kit (CD431).

The following tools are used for stamping cores and keys in your system.

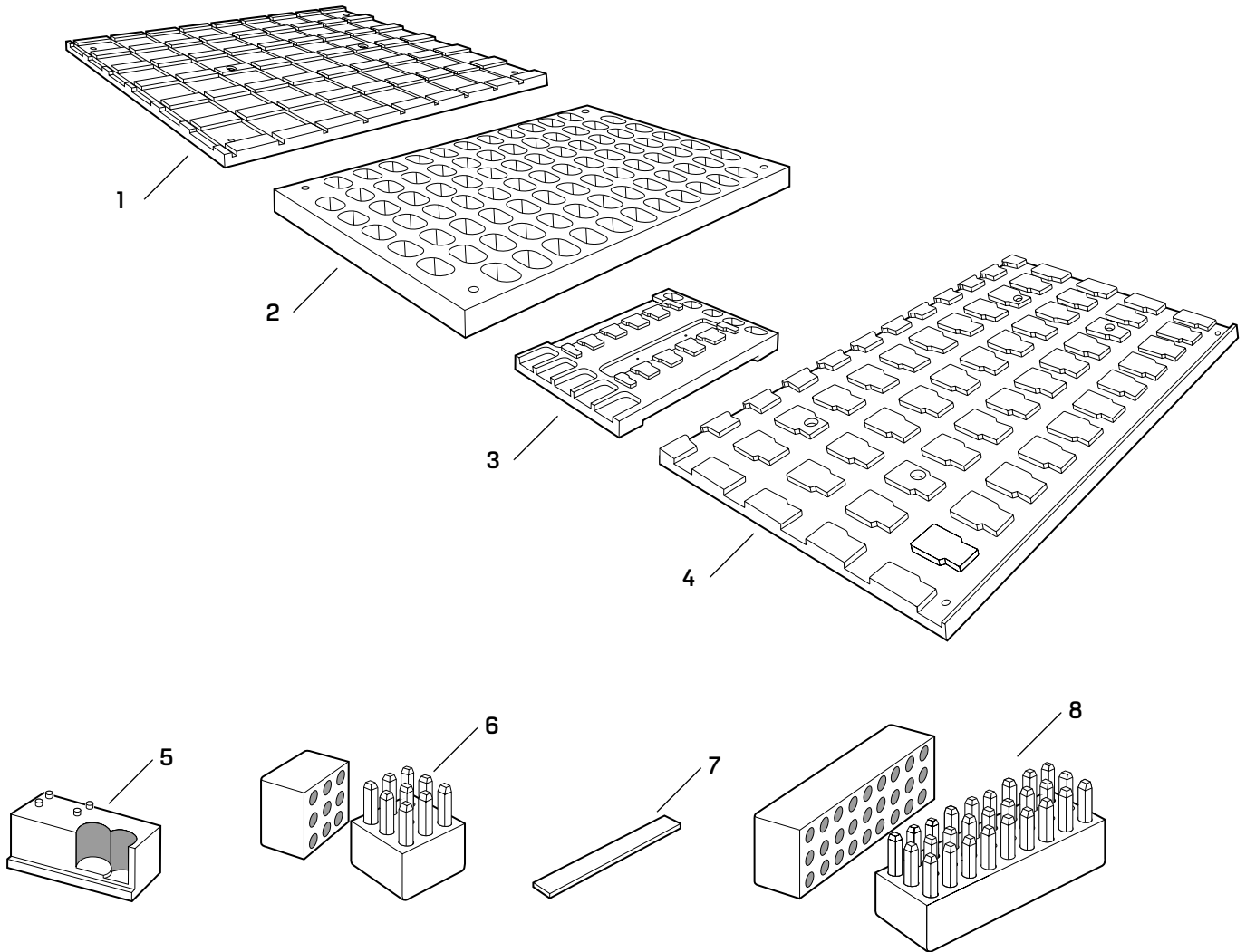

Figure 2.12 Stamping tools

Item	Nomenclature	Description
1	CD504C	Core stamping plate—side only [for 50 cores]
2	CD504B	Core stamping plate—face only [for 87 cores]
3	DD514	Core/key marking plate
4	AD504A	Key stamping plate [for 55 keys]
5	DD513	Core/key marking block
6	DD503	Number dies [1/16" or 3/32"]
7	DD514A	Magnetic strip ^a
8	DD502	Letter dies [1/16" or 3/32"]

a. A set of 3 is included with the core/key marking plate (DD514).

The following items are used to lubricate cores and keys.

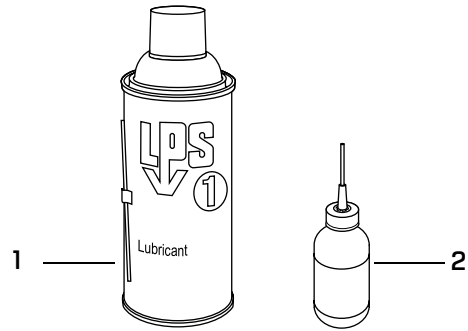

Figure 2.13 Lubrication items

Item	Nomenclature	Description
1	DD537	LPS spray can
2	CD535	Graphite gun
not shown	CD535A	1 pound container of graphite

3

SERVICING AND TROUBLESHOOTING

This chapter contains instructions for servicing components and troubleshooting common problems.

PLACING PIN SEGMENTS, SPRINGS, AND CAPS IN A CORE

Overview of how a key works in the core

BEST cores have two shearlines. The upper, or control, shearline lets you remove the core from the door. The lower, or operating, shearline lets you operate the key in the lock.

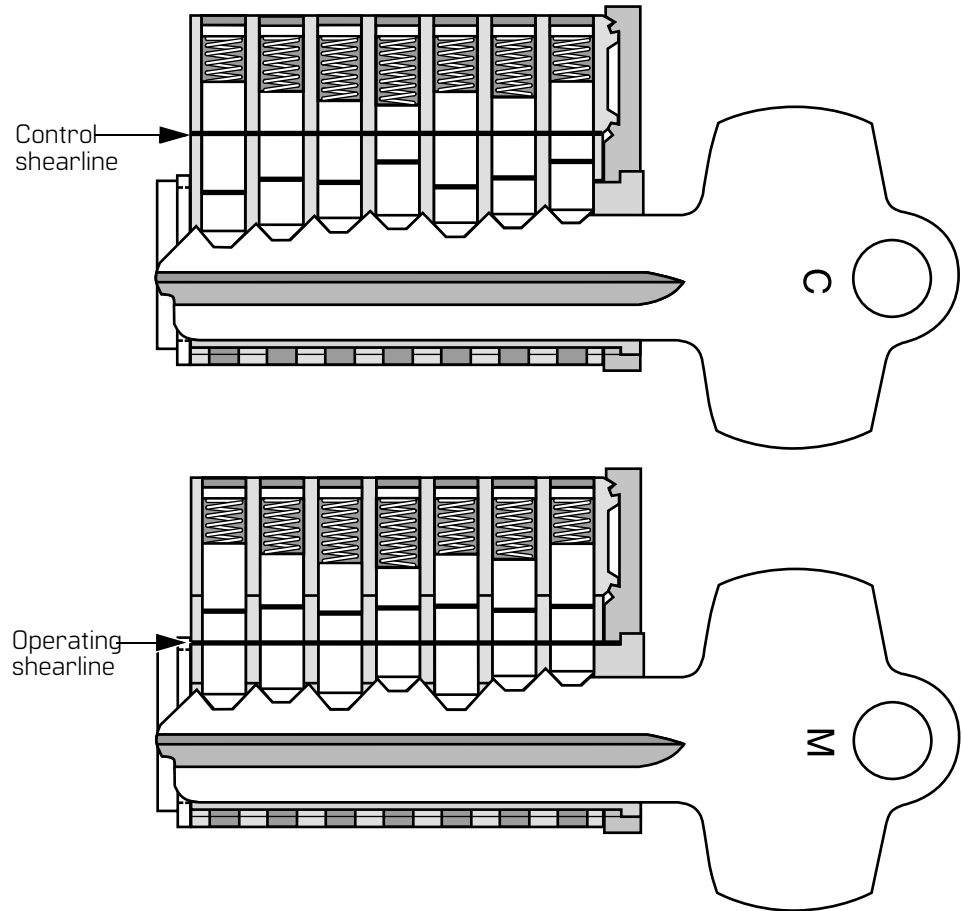

Figure 3.1 Cross section of a core showing control and operating shearlines

Loading the core

To determine the specific sequence of segments to place in each core, please refer to the *Masterkey Code Sheet* and the *Combining Instruction Sheet* supplied to you by dormakaba.

Note: For information about loading cores used for UL applications, see [page 2–7](#).

1. Before you begin, identify the parts of the core you will be working with. The front of the core is identified by the BEST logo. Barrel number one is at the back of the core.

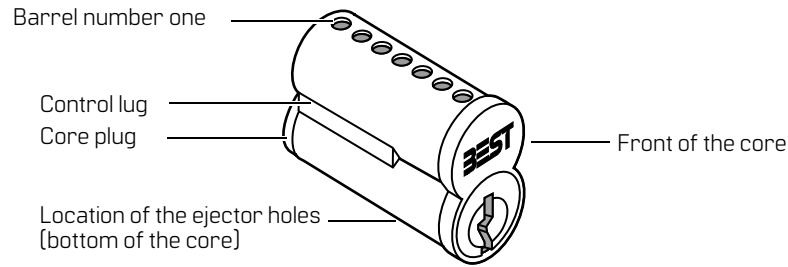

Figure 3.2 Identifying the parts of the core

2. Insert the ejector pin into the notch on the back of the sleeve and push the control lug into the thrown (extended) position. Remove the ejector pin from the notch.

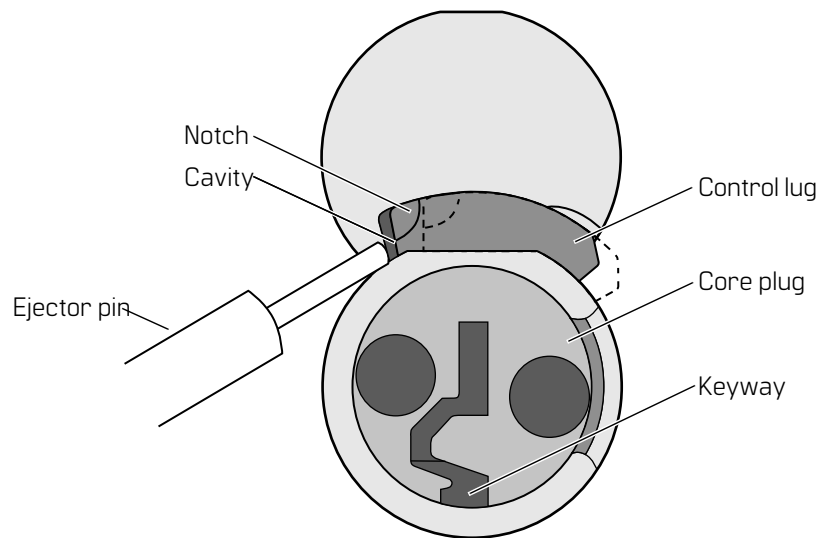

Figure 3.3 Pushing the control lug into the thrown position

3. Insert the ejector pin into the cavity between the lug and core body to hold the lug in the thrown position. Use your thumb and forefinger to rotate the core plug until the keyway is straight up and down, and the bottom of the keyway is in the six o'clock position. Remove the ejector pin from the cavity.

4. Insert the ejector pin into barrel number seven to ensure that the barrels stay aligned. Leave the ejector pin inserted while you perform the next step.
5. Use your combining instruction sheet to determine what segments are required for barrel number one. Insert the bottom segment, beveled end down, into barrel number one.
6. Remove the ejector pin from barrel number seven and use it to tap down the segment until it seats at the bottom of the barrel. You should see the segment protruding into the keyway.
7. Insert the next required segment into barrel number one. Use the ejector pin to tap down the segment until it is seated.
8. Repeat step 5 through step 7 until all of the required segments are loaded into all of the barrels.

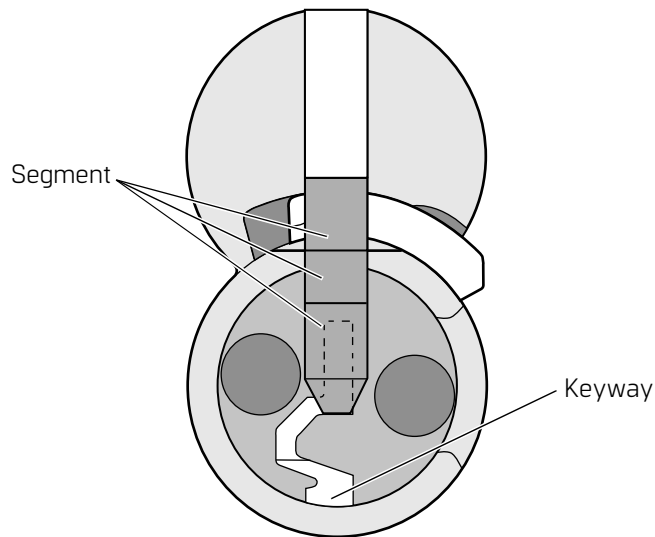

Figure 3.4 Inserting the segments into the barrel

9. Insert the stop pin into the appropriate hole in the side of the capping block to align the core barrels with the holes in the capping block.

10. Insert the core into the capping block.

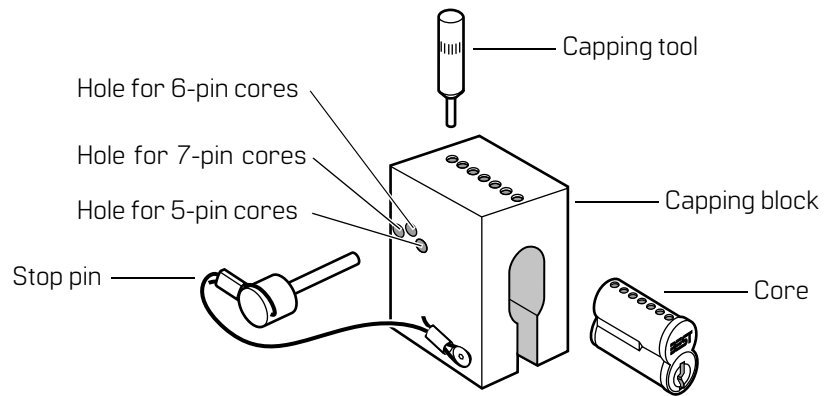

Figure 3.5 Inserting the stop pin and core into the capping block

11. Insert a spring into barrel number one. Place a cap over the barrel.

Note: Do not cut the segment springs and insert an extra cap.

12. Insert the capping tool into barrel number one. Use a hammer to tap the capping tool and drive down the cap until the bottom of the capping tool hits the top of the capping block.

Drive cap to this depth. (.025 to .040 inches)

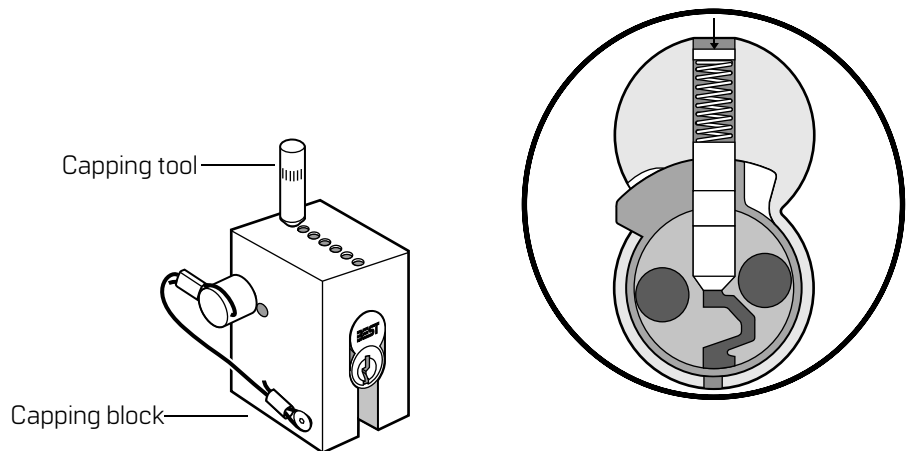

Figure 3.6 Seating the cap in the barrel

13. Repeat step 11 and step 12 until all of the barrels are capped.

14. Test all keys, including the control, grandmaster, and operating keys, in the core to make sure that each barrel is loaded correctly. **Note:** If a barrel is not loaded correctly, insert the ejector pin through the ejector holes and tap out the segments, spring, and cap. Discard the used segments, spring, and cap, and reload the barrel.

Special guidelines

When stamping and loading the core, follow the guidelines below.

- If the core is not operating smoothly while you are loading it, do not tap the core against a metallic block. Use a block made of nylon or an equivalent material.
- Do not use a metal-headed hammer on cores. Use a plastic-headed hammer only.
- Do not use excessive force to stamp core markings on the side of cores. Excessive force may cause the barrel opening to close slightly.
- Do not stamp the core on the bottom lobe.
- Do not enlarge segment holes. This may cause problems with segment capping.

Checking a core for proper operation

Periodically test all of your keys, including the control, grandmaster, and operating keys in the core to make sure that the core is operating properly.

Insert a key in the core. If you can insert, turn, and remove the key easily, the core and key are working properly. If not, see the troubleshooting section on [page 3-11](#).

REPLACING A DUST COVER ASSEMBLY

1. Unscrew the screw and remove the dust cover and dust cover hinge.
2. Place the dust cover over the key hole in the core so that the lip faces away from the core. Place the dust cover hinge on the face of the core with the prongs covering the dust cover, as shown in [Figure 3.7](#). Install the screw.

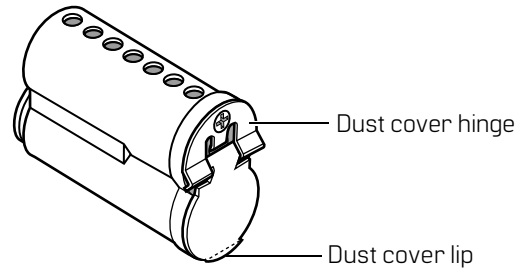

Figure 3.7 Dust cover assembly in position

LUBRICATING A CORE

Create a preventive maintenance plan that includes lubricating the core. To extend the life of the core, lubricate it regularly. Powdered graphite is the best choice for lubrication; LPS spray is also used.



Do not lubricate a core with oil. Doing so will attract dirt.

For powdered graphite lubrication:

1. Remove the core from the lock.
2. Dip a key in graphite. With the core inverted, insert the key into the keyhole and remove it; repeat several times, allowing the graphite to penetrate the barrels. *OR*

With the core inverted, spray graphite into the keyhole. Insert the key into the keyhole and remove it; repeat several times, allowing the graphite to penetrate the barrels.

For LPS lubrication:

1. Remove the core from the lock.
2. Spray compressed air or LPS lubricant into the core to clean out all of the existing lubricant.
3. With the core inverted, spray the lubricant into the key opening, allowing the spray to penetrate the barrels.



Do not mix graphite with LPS lubricant.

THAWING A CORE



Caution

Do not heat the core with a propane torch. This will cause internal damage and possibly cause the core to become inoperable.

If the core is frozen, try the following techniques to thaw it.

- Spray LPS lubricant into the key opening to reduce the moisture inside the core.
- Heat the key and insert it into the core.
- Spray a commercial lock antifreeze or ice dissolver into the core.

TROUBLESHOOTING

This table summarizes the possible causes for the most common core and key problems. The causes are listed in the order of likelihood. [The most likely cause is first, and so forth.]

You notice...	Possible causes include...	You should...
It is difficult to insert or remove the key.	<ul style="list-style-type: none"> a. Key's keyway is not compatible with the core. b. Key is damaged. c. There is foreign material on the key or in keyway of the core. d. Keyway of the core has been damaged. e. Barrels of the core are not loaded correctly. f. Caps are inserted too deeply into the barrels. 	<ul style="list-style-type: none"> a. Look at the end of the key and the keyway of the core. If the profiles do not match, check your <i>Masterkey Specification</i> to see what type of keyway must be used with the core. b. Check the key to see whether it has been damaged. If it has, replace the key. c. Check the key and the keyway of the core for foreign material. If there is foreign material, remove it with compressed air or LPS lubricant. d. Check the keyway of the core for damage. If it is damaged, contact your dormakaba Representative. e1. Check inside the keyway to see whether the ends of the bottom segments that protrude into the keyway are flat or beveled. If any of the bottom segments appear to be inserted incorrectly, reload that barrel with new segments, spring, and cap. Make sure the beveled end of the bottom segment is inserted first into the barrel. e2. Perform the thumb check procedure to see whether the height of any segment stack varies. [See page 3–14.] e3. If the problem still is not solved, check the <i>Masterkey Specification</i> for errors. Reload the core and cut new keys as necessary. f. From the top of the core, look into the barrels, or use a depth gauge to see whether one or more caps is inserted more deeply into the barrel. [The correct cap depth is .025 to .040 inches from the top of the core.] If so, reload the barrel with new segments, spring, and cap.

You notice...	Possible causes include...	You should...
Key does not rotate the core plug or control lug.	a. Key is cut improperly. b. Barrels of the core are not loaded correctly. c. Key combinator needs to be recalibrated.	a. Use the key cut indicator to determine whether the key was cut correctly. [See page 3–15 .] If the key cuts are not correct, cut a new key. b. Reload the core with new segments, springs, and caps. If the key still does not rotate, check the <i>Masterkey Specification</i> for errors. c. If you cut a new key and you are still having the problem, the Key Combinator may need to be recalibrated. See the <i>Key Combinator Service Manual</i> .
Key does not rotate smoothly.	a. Key is cut improperly. b. Barrels of the core are not loaded correctly. c. Key combinator needs to be recalibrated.	a. Use the key cut indicator to determine whether the key was cut correctly. [See page 3–15 .] If the key cuts are not correct, cut a new key. b1. Check inside the keyway to see whether the ends of the bottom segments that protrude into the keyway are flat or beveled. If any of the bottom segments appear to be inserted incorrectly, reload that barrel with new segments, spring, and cap. Make sure the beveled end of the bottom segment is inserted first into the barrel. b2. Perform the thumb check procedure to see whether the height of any segment stack varies. [See page 3–14 .] b3. If the problem still is not solved, check the <i>Masterkey Specification</i> for errors. Reload the core and cut new keys as necessary. c. If you cut a new key and you are still having the problem, the Key Combinator may need to be recalibrated. See the <i>Key Combinator Service Manual</i> .

You notice...	Possible causes include...	You should...
Core does not insert into cylinder/receptacle.	<ul style="list-style-type: none"> a. Core lug is not fully retracted. b. Throw pins inside the receptacle are not aligned with the holes in the core. c. There is foreign material in the cylinder/receptacle. d. For mortise locks only, the cylinder set screw is installed too tightly. 	<ul style="list-style-type: none"> a. Check behind the lug for any foreign material. Clean it as necessary. b. Check to see whether the throw pins are out of alignment. Use a screwdriver to align the throw pins with the throw pin holes in the core. c. Check the cylinder/receptacle for foreign material. Clean it as necessary. d. Remove the mortise case faceplate and loosen the cylinder set screw.

Performing the thumb check procedure

Perform the following steps to check each barrel of the core to make sure that the segment stacks are of equal height.

1. Insert the ejector pin into the number one ejector hole.
2. Use your thumb to mark the depth on the ejector pin. Keep your thumb in place.

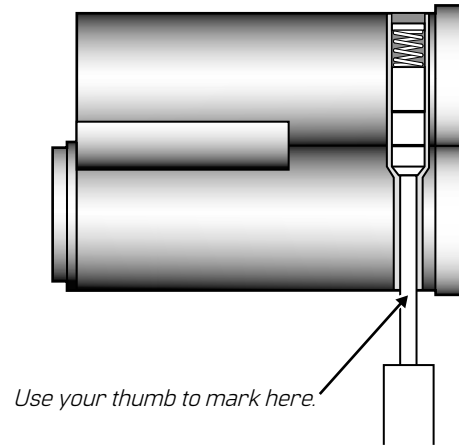

Figure 3.8 Using the ejector pin to mark the segment stack height

3. Insert the pin into the other ejector holes. If the segment stack height varies, use the ejector pin to force out the segments, springs, and caps of the barrels that are incorrectly loaded. Discard the used segments, springs, and caps. Reload the barrels with new segments, springs, and caps.

Using the key cut indicator

1. Insert your key into the key cut indicator that is appropriate for your keying system, with the key cuts facing the numbers on the key cut indicator.
2. Slide the key until it contacts the indicator at the top and bottom. Read the key cut number that aligns with the position of the key.
3. Make sure that the key cut corresponds to the key cut for that position listed on your *Masterkey Specification*. If the key cut does not match what is listed, cut a new key.
4. Repeat step 1 through step 3 for each key cut on your key.

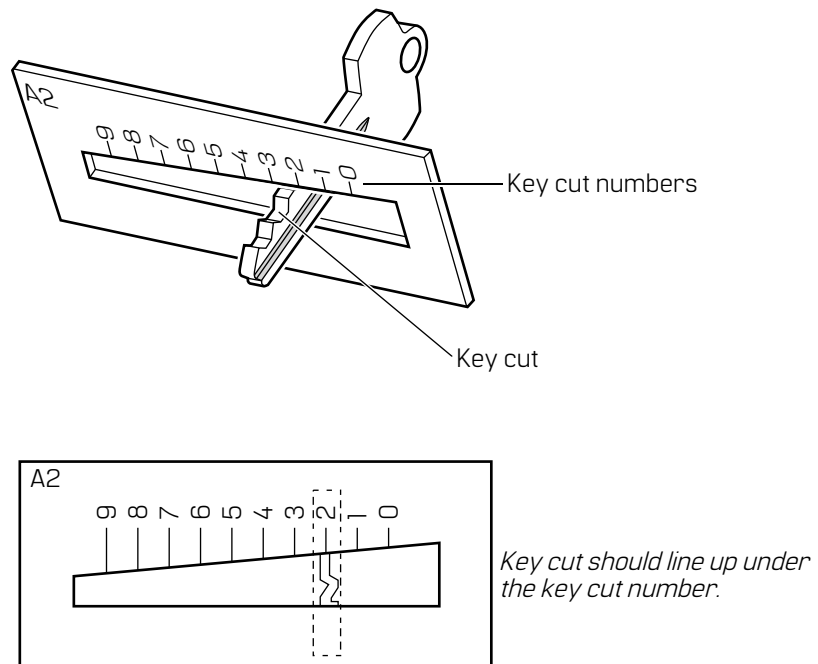

Figure 3.9 Using the key cut indicator

A

GLOSSARY

Combining	The process of determining the combination of the length of segments used and the order they are loaded into the barrels of a core. Also, the process of making the cuts of different depths in a key blade that let it operate or remove a corresponding core.
Control key	A key that can insert or remove any core in a system.
Grandmaster key	A key that can unlock any lock in a system.
Interchangeable core	A figure-8 shaped device that contains all mechanical parts for a masterkeyed system. The interchangeable core can be removed by a special control key and can be recombined without disassembling the lock.
Key blank	A key that has no key cuts.
Key cut	A notch in a key.
Keyway	The slot in the core used to receive and guide the key. Also, the shape of the key blade determined by the location, length, width, and depth of grooves milled in the key blade.
Loading a core	The process of inserting segments, springs, and caps into each barrel of a core according to predetermined specifications.
Masterkeying	A method of keying locks that allows a single key to operate many locks, but also allows each lock to be operated by its own key.
Operating key	A key that can unlock a single lock within a system.

- Shearline** The alignment of segments in the core that is created when a key is inserted. The shearline lets the key operate the core or remove the core from the lock.
- Submaster key** A key that can unlock only specified groups of locks within a system.
- Thumb check procedure** A series of steps performed to check that the segment stacks are of equal height in each barrel of a core.

B

INDEX

Symbols

#4-40 pan head screw [2-8](#)

C

capping block

part drawing for [2-12](#)

part number for [2-13](#)

caps [2-6](#)

certifications and standards [1-2](#)

checking a core for proper operation [3-7](#)

combinating bin

part drawing for [2-12](#)

part number for [2-13](#)

combinating code

ordering [2-3](#)

combinating hammer

part drawing for [2-12](#)

part number for [2-13](#)

combinating kit

part drawing for [2-12](#)

part number for [2-13](#)

combinating the core [3-3](#)

control shearline [3-2](#) core

loading [3-3](#)

lubricating [3-9](#)

ordering [2-3](#)

overview diagram [2-2](#)

thawing [3-10](#)

core capping press

part drawing for [2-12](#)

part number for [2-13](#)

core marking plate

see marking plate

core options

descriptions [2-5](#)

ordering [2-3](#)

core size

ordering [2-3](#)

core stamping plate

see stamping plate

core type

core [2-3](#)

descriptions [2-4](#)

ordering [2-3](#)

cut code

ordering [2-9](#)

D

dies [2-14](#)

documentation package [1-3](#)

dust cover [2-8](#)

dust cover assembly [2-8](#), [3-8](#)

dust cover hinge [2-8](#)

E

ejector pin

part drawing for [2-12](#)

part number for [2-13](#)

G

graphite [2-15](#)

graphite gun [2-15](#)

H

hand capping pin

part drawing for [2-12](#)

part number for [2-13](#)

how to order

see ordering

K

key

ordering 2-9

overview diagram 2-9

key combinator

part drawing for 2-12

part number for 2-13

key cut indicator

part drawing for 2-12

part number for 2-13

using 3-15

key marking plate

see marking plate

key options

ordering 2-9

key shape

ordering 2-9

key stamp

descriptions 2-11

ordering 2-9

key stamping plate

see stamping plate

key type

descriptions 2-10

ordering 2-9

keyway, core

ordering 2-3

keyway, key

ordering 2-9

L

letter dies

see dies

loading the core 3-3

LPS spray can 2-15

lubricating a core 3-9

M

magnetic strip 2-14

marking block 2-14

marking plate 2-14

N

number dies

see dies

O

operating shearline 3-2

ordering

caps 2-6

key 2-9

segments 2-6

springs 2-6

overview

core 2-2

how a key works in a core 3-2

key 2-9

product family diagram 1-2

P

performing the thumb check

procedure 3-14

plastic heads for combining

hammer 2-13

product family diagram 1-2

R

replacing a dust cover assembly 3-8

S

segments 2-6

shearline 3-2

springs 2-6

stamping plate 2-14

standard finishes

ordering 2-3

support, technical 1-3

T

technical documentation package

1-3

technical support 1-3

thawing a core 3-10

thumb check procedure 3-14

troubleshooting 3-11

tweezers

part drawing for 2-12

part number for 2-13

U

using the key cut indicator 3-15

