

# Installation Instructions Surface Vertical Rod Exit Device - Reversible

## Series 2200, FL2200, 2200LBR & FL2200LBR

For online instructions, assistance or warranty information:  
Call 1-800-392-5209 or visit <https://dhwsupport.dormakaba.com/hc/en-us>

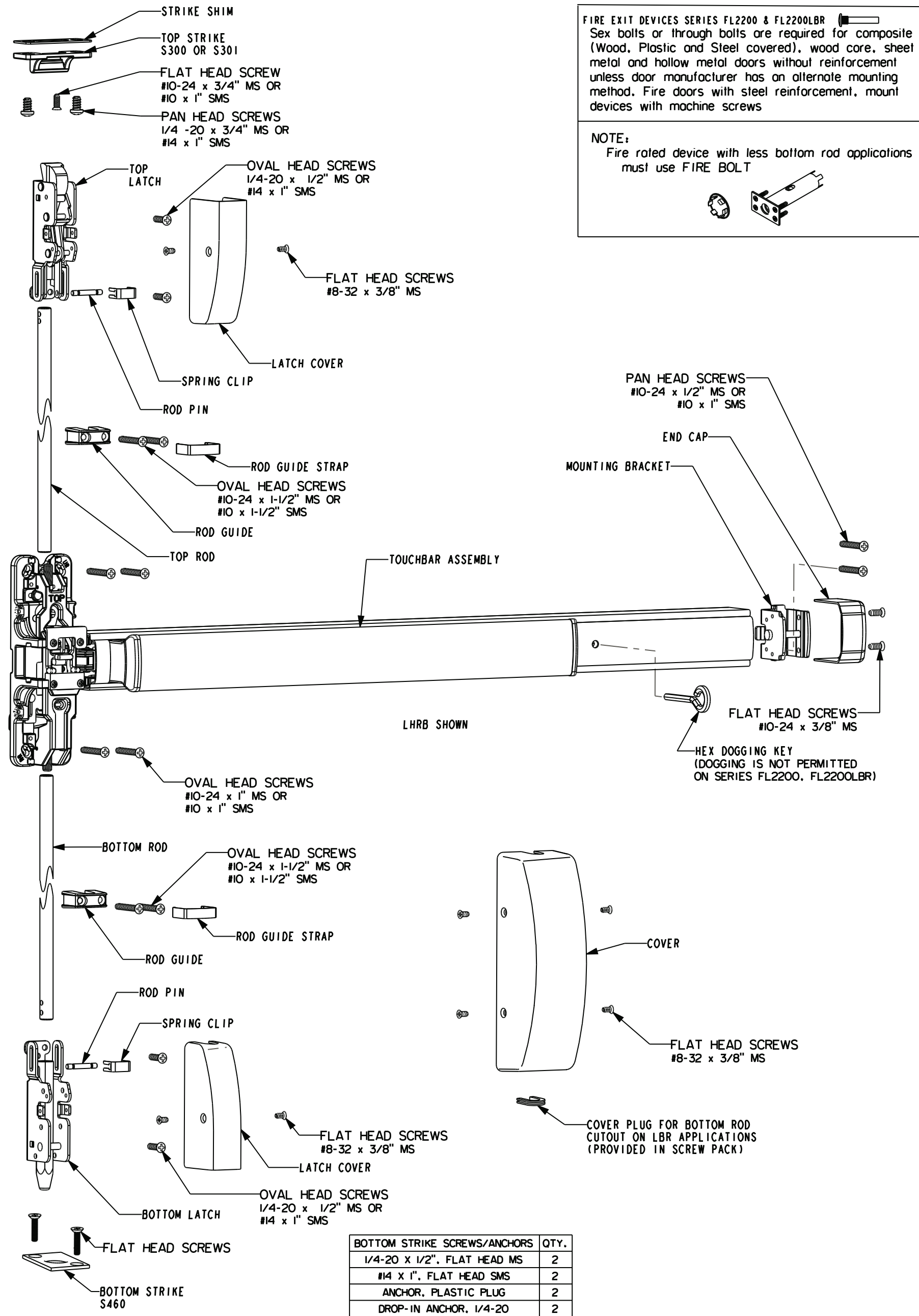

### INSTRUCTIONS TO CHANGE HAND

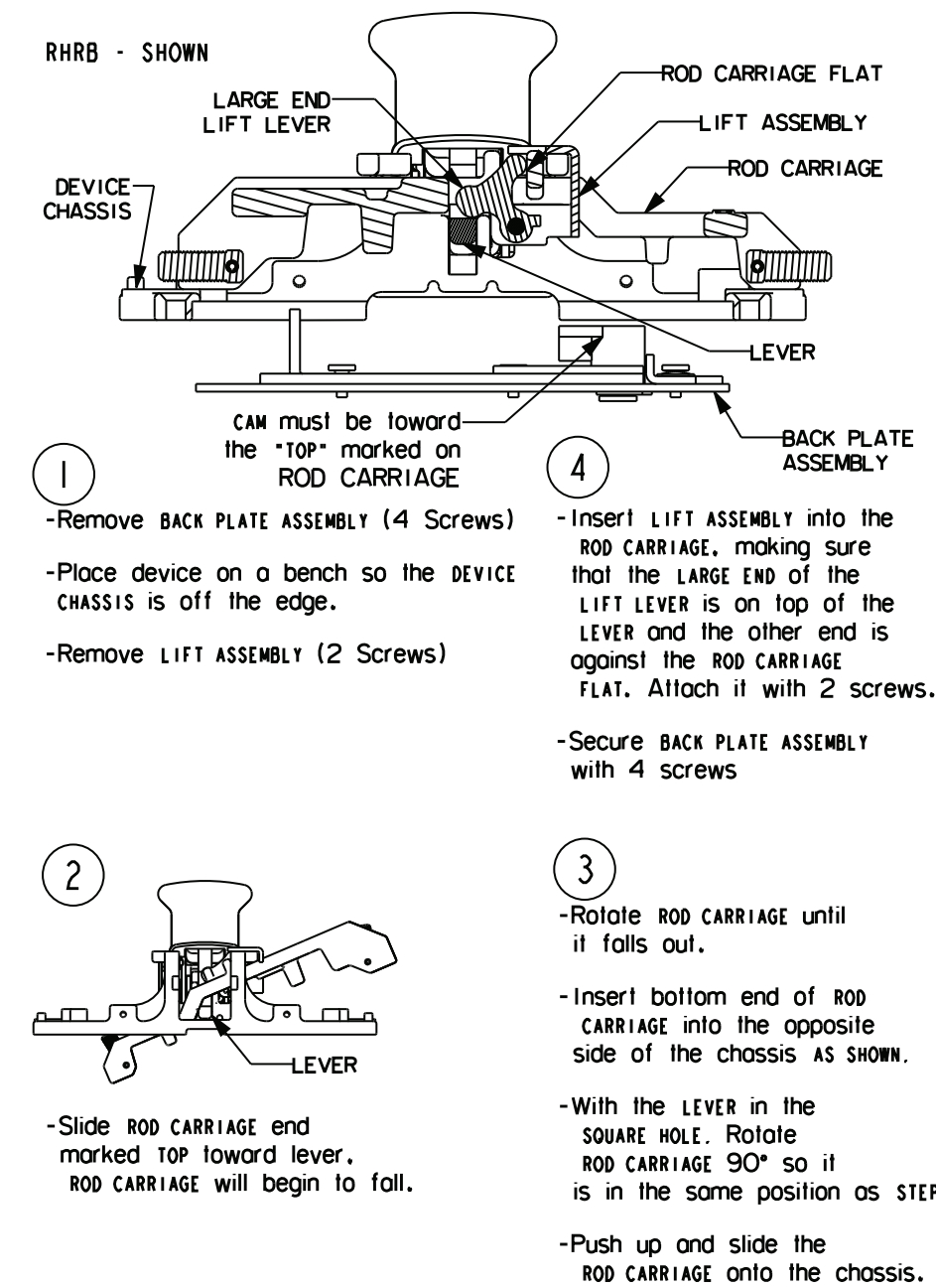

### INSTRUCTIONS TO CHANGE FUNCTION

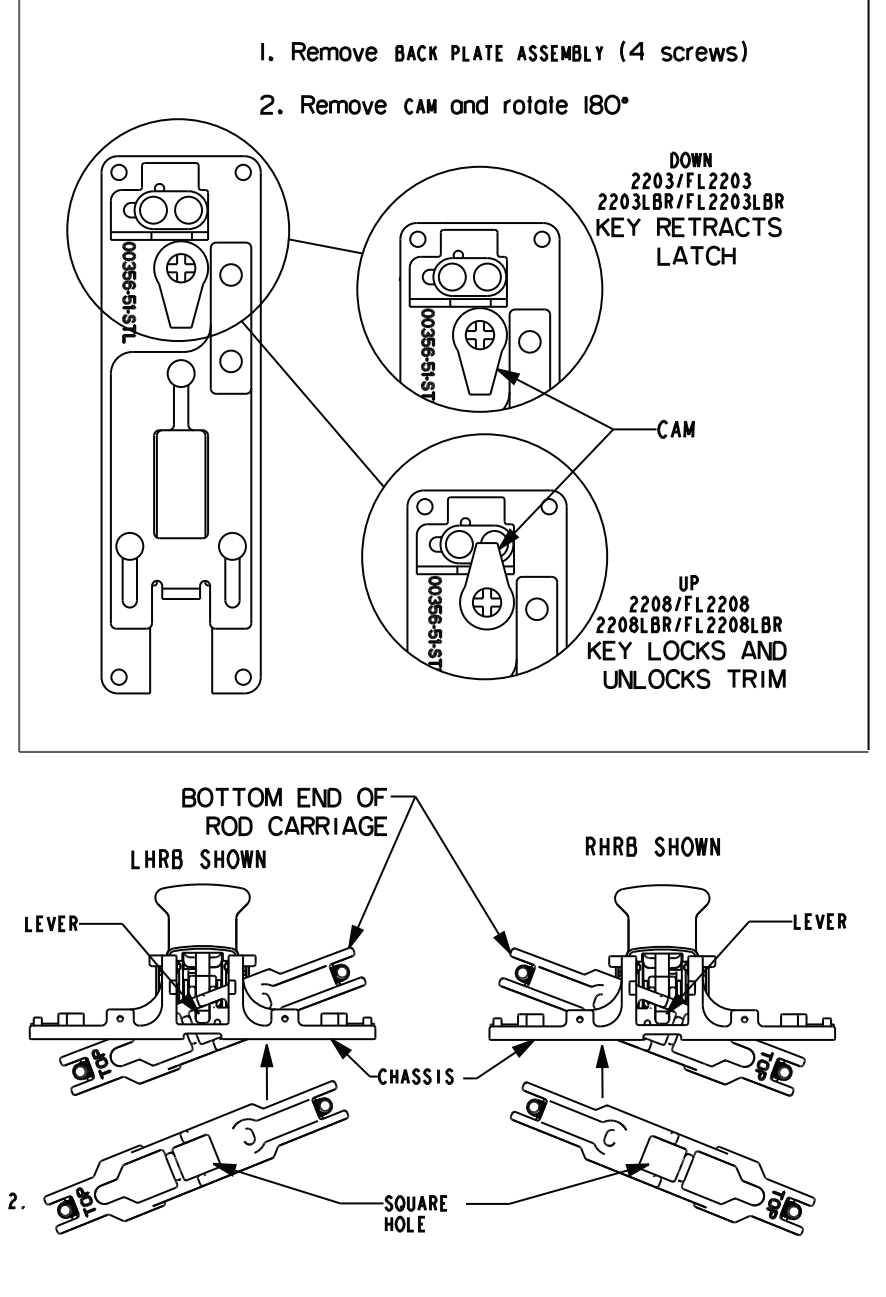

### DEVICE PREPARATION

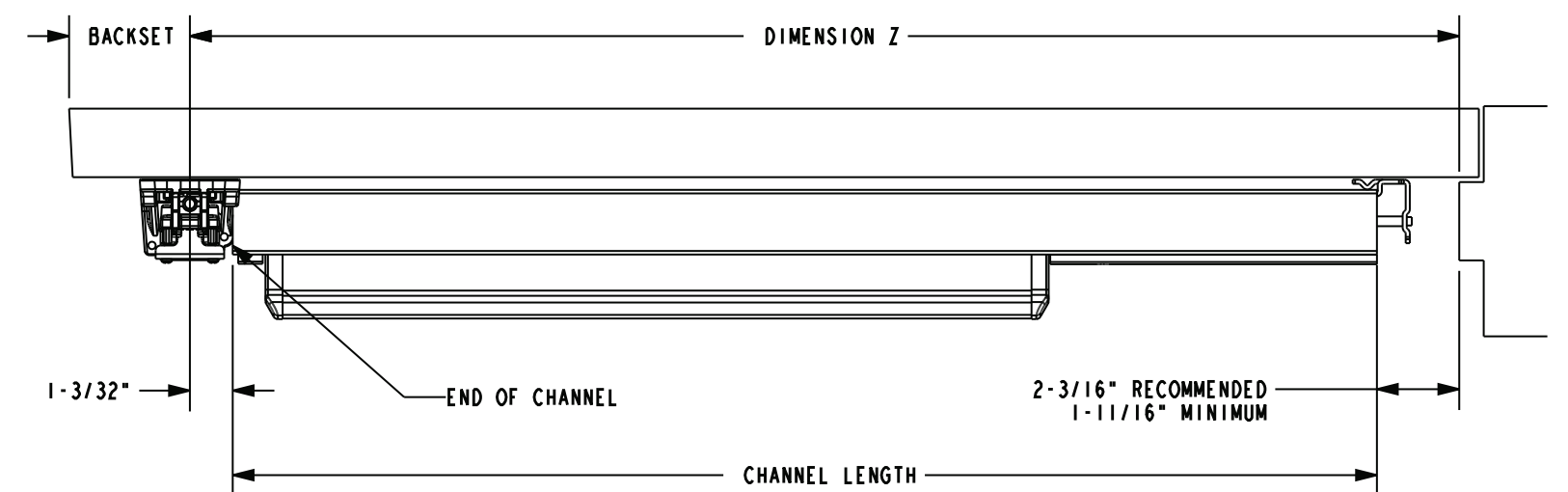

# 1 DOOR PREPARATION

1. Circle the TRIM NUMBER, (if specified) at various locations (holes B and C) on the TRIM TEMPLATE.
  2. Mark HORIZONTAL CENTERLINE on inside face of door 39-15/16" from finished floor as shown. (Continue horizontal centerline to outside face of door if Trim is specified).
  3. Mark VERTICAL CENTERLINE per BACKSET indicated at lock side on full height of door and carry it onto the under side of the DOOR STOP. (If trim is specified mark vertical centerline at lock side using Backset dimension on outside face of door).
- CAUTION: Vertical centerlines on both sides of the door should be the same dimension from the edge of the door.
4. Tape LOCK STILE CASE, TOP LATCH, and BOTTOM LATCH Templates (and Trim Template if Trim specified) to the door so that the centerlines on the Template line up with centerlines on the door. Mark centers and drill the required holes as indicated on the templates.

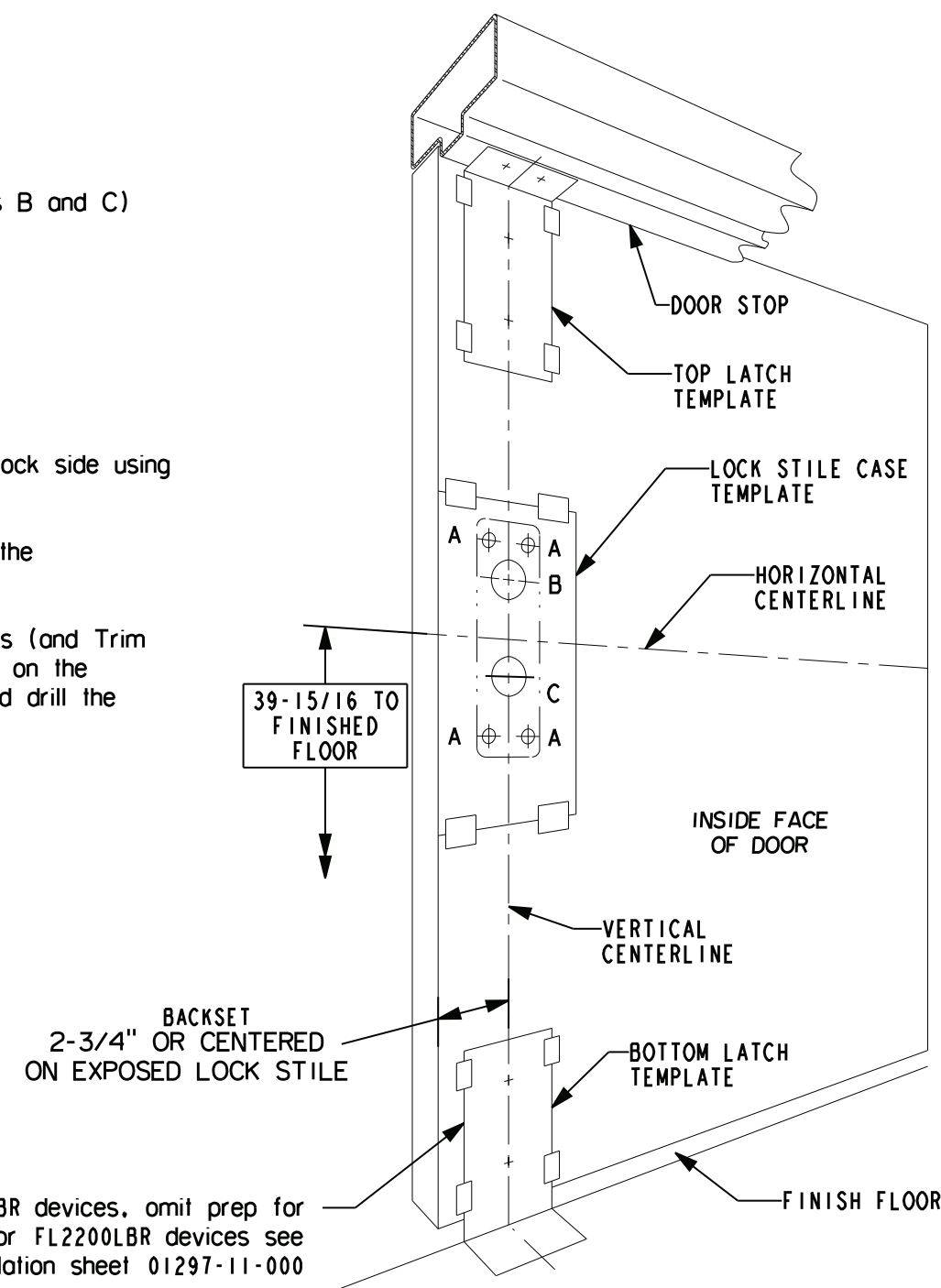

CAUTION: For LBR devices, omit prep for bottom latch, for FL2200LBR devices see fire bolt installation sheet 01297-11-000

# 2 APPLY DEVICE

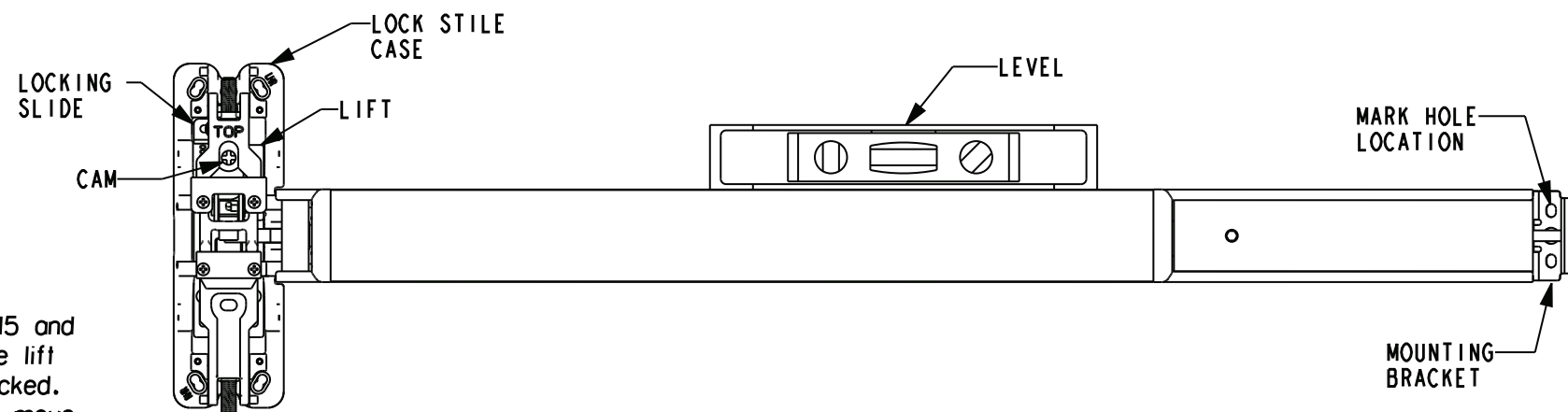

CAUTION: For 1715, 2015 and 4914 trim the lift must be unlocked. The cam will move locking slide away from lift to unlock.

NOTE: If Trim is specified: See the Trim installation instructions packaged with the trim. If the Exit Device has Electrical or other options see specific option instructions packaged in exit device carton.

1. Lock Stile Case Mounting  
 DEVICE WITH TRIM - See Trim instructions  
 CYLINDER ONLY - Install cylinder with cylinder back plate as shown. Make sure the tailpiece is extending 1/2" to 7/8" from the inside face of door. Insert tailpiece into CAM in the lock stile case and mount it to the door with 4 screws.  
 EXIT ONLY - Mount Lock Stile Case to the door with 4 screws.
2. Insert MOUNTING BRACKET into touch bar assembly tight against channel. Level device, mark and drill 2 holes for #10 sheet metal screws or #10-24 machine screws. Fasten MOUNTING BRACKET to door and attach ENDCAP with 2 flat head screws.

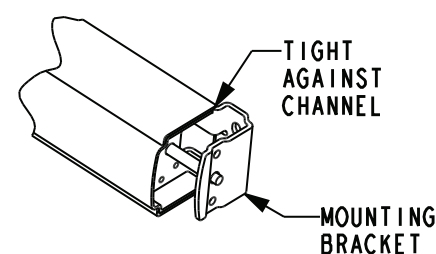
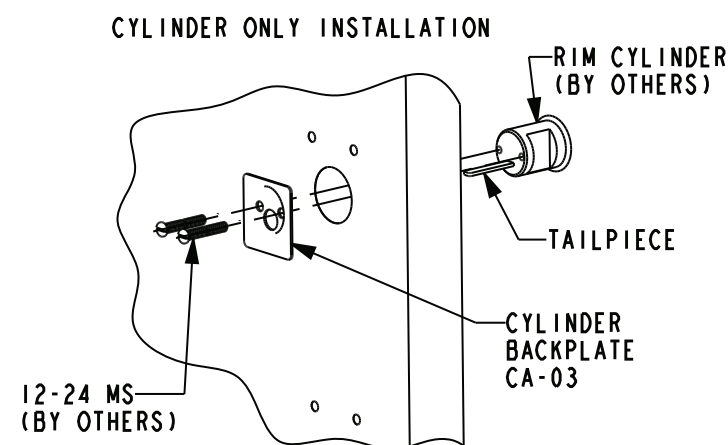

# 3 APPLY LATCHES AND RODS

1. Mount top latch assembly with 2 pan head screws.
2. Fasten top strike to frame with 2 screws and star washers. Adjust strike so that device latches without binding. Strike shims are provided if an excessive gap is apparent between latchbolt and strike. Apply third screw in center hole of strike once adjustment is complete.
3. Determine rod lengths as shown. Cut rod if necessary. Cut end of rod with holes; NOT THE THREADED END. Drill 3/16 diameter hole thru rod. See ILLUSTRATION 1.
4. With rod carriage down, thread top rod onto stud in rod carriage until hole in top rod aligns with bottom of slot in top channel. Pull link down so the hole in the link is at the bottom of the slot in the channel. Insert rod pin thru channel, link and rod. Push spring clip onto rod pin until it snaps into place.
  - A. Pushing on touchbar will retract the latchbolt and open the door. Latchbolt will stay retracted and device is in HOLDBACK.
  - B. IF NO HOLDBACK: Remove spring clip and rod pin, Turn rod counter clockwise one half turn, insert rod pin and check holdback. Repeat if necessary.
  - C. When top latch is in holdback, extend latchbolt by rotating II. Fully extended latchbolt should be in deadlock. DEADLOCKED Latchbolt can not be pushed down into the latch channel.
  - D. IF NO DEADLOCK: Remove rod pin, Turn rod clockwise one half turn, insert rod pin and check deadlock. Repeat if necessary and install spring clip.
5. For "LBR" devices attach latch and lock stile case covers.
6. Mount bottom channel with 2 pan head screws.
7. With the rod carriage down, thread the bottom rod onto the stud in the rod carriage until the appropriate hole (see ILLUSTRATION 1 below) in the rod aligns with bottom of slot in the bottom channel, insert rod into the bolt by lifting it up. Insert rod pin thru channel, bolt and then rod.
8. Place device in holdback by pushing on touchbar. Clearance between the bottom of the bolt and the surface where strike will be mounted should be 1/4". If clearance is not 1/4", remove rod pin and thread rod into the rod carriage to achieve 1/4" clearance. Install rod pin and spring clip.
- 9A. FOR FLOOR APPLICATION: Center strike around bolt. Mark floor for fasteners, prepare floor according to the type of fastener furnished. Provide clearance in floor for bolt.
- 9B. FOR THRESHOLD APPLICATION: Center strike around bolt. Provide hole in threshold to accept the bolt. Mark threshold for fasteners. Prepare the threshold according to type of fasteners furnished.
10. Position rod guides midway between latches and lock stile case, centered on rods. Mark, drill and fasten guides with 2 screws - Snap rod guide straps into position.
11. Attach all covers with screws. For LBR applications, install cover plug (provided in screw pack) for bottom rod cutout in chassis cover prior to securing cover with screws.

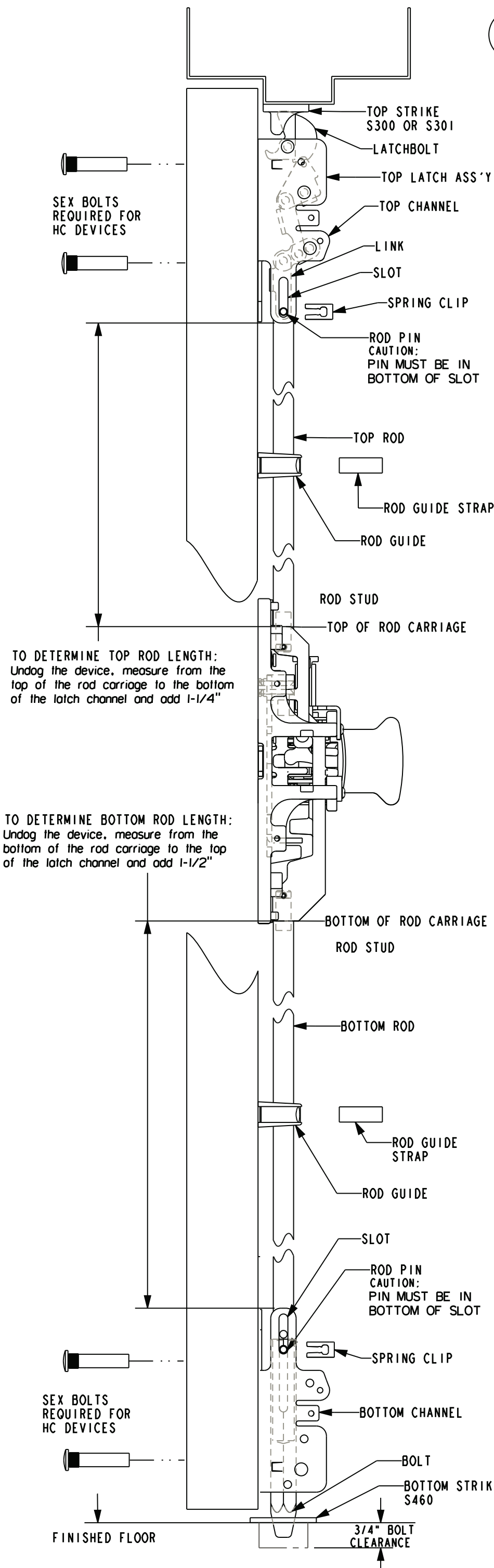

TO DETERMINE TOP ROD LENGTH: Undo the device, measure from the top of the rod carriage to the bottom of the latch channel and add 1-1/4"

TO DETERMINE BOTTOM ROD LENGTH: Undo the device, measure from the bottom of the rod carriage to the top of the latch channel and add 1-1/2"

