

Installation Instructions Surface Vertical Rod Exit Device - Reversible Series 5200, FL5200, 5200LBR & FL5200LBR

For online instructions, assistance or warranty information:
Call 1-800-392-5209 or visit <https://dhwsupport.dormakaba.com/hc/en-us>

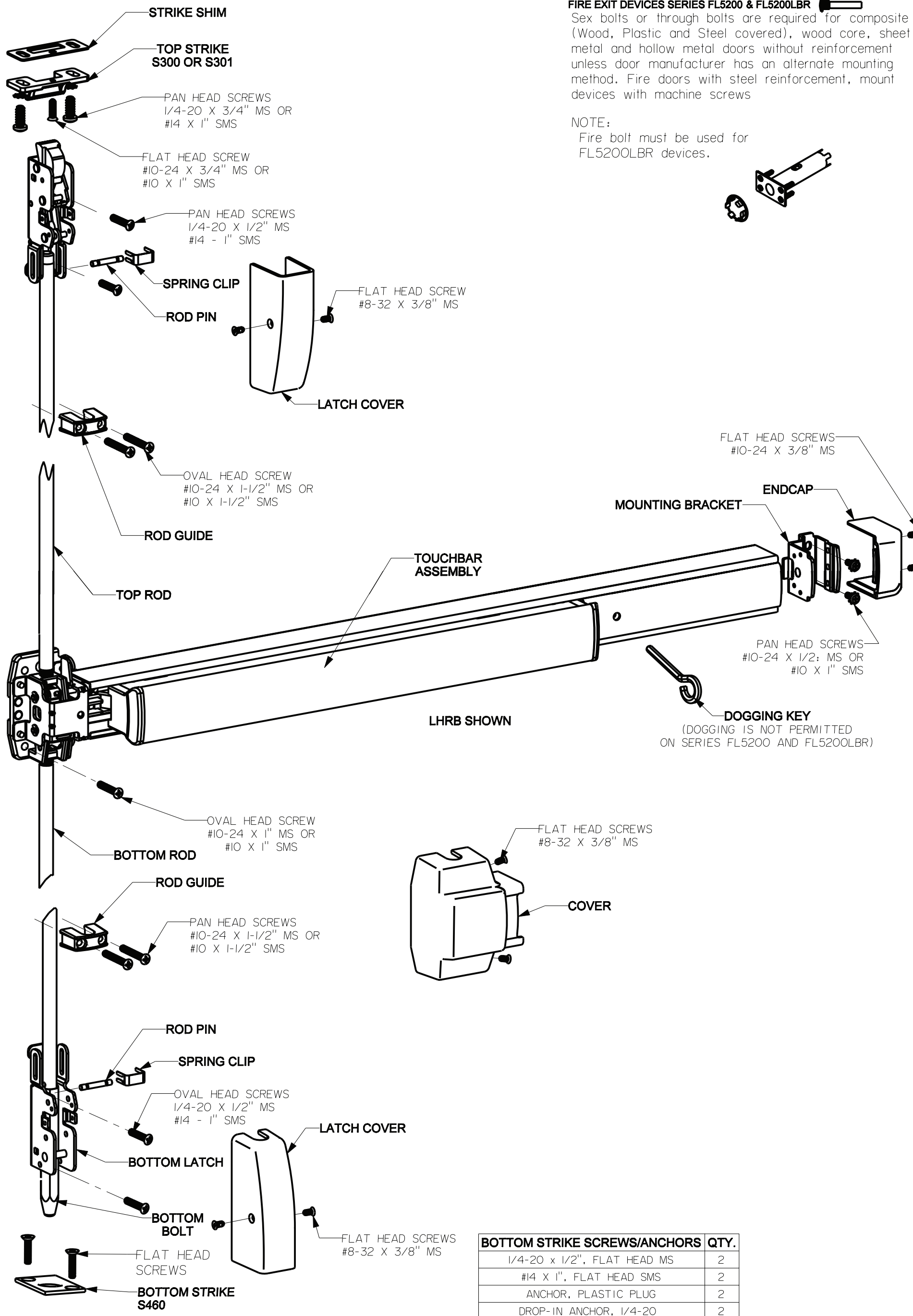

FIRE EXIT DEVICES SERIES FL5200 & FL5200LBR
Six bolts or through bolts are required for composite (Wood, Plastic and Steel covered), wood core, sheet metal and hollow metal doors without reinforcement unless door manufacturer has an alternate mounting method. Fire doors with steel reinforcement, mount devices with machine screws

NOTE:
Fire bolt must be used for FL5200LBR devices.

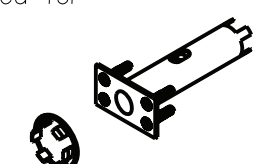

INSTRUCTIONS TO CHANGE HAND

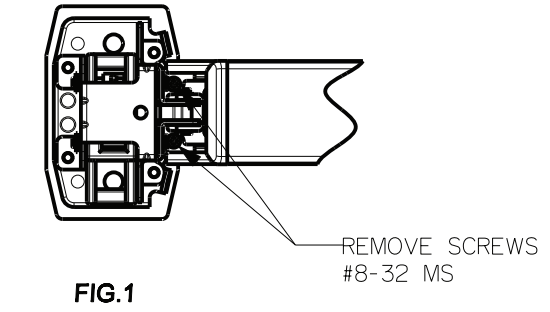

1. Remove the 2 channel screws.(fig. 1) and slide device channel away from chassis (fig. 2)
2. Remove Lift by removing retaining ring and sliding the pin out.
3. Insert screwdriver in the sub plate slot to keep lever end down.
4. Slide pin out from the opposite side by removing retaining ring. Secure Lift at this location with pin and retaining ring
NOTE: Make sure the large end of Lift is on top of lever and the other end is against the rod carriage flat.
5. Slide the other pin back and secure it with retaining ring.
6. Slide device channel back to the chassis and secure it with 2 screws. Slide in the hinge filler.

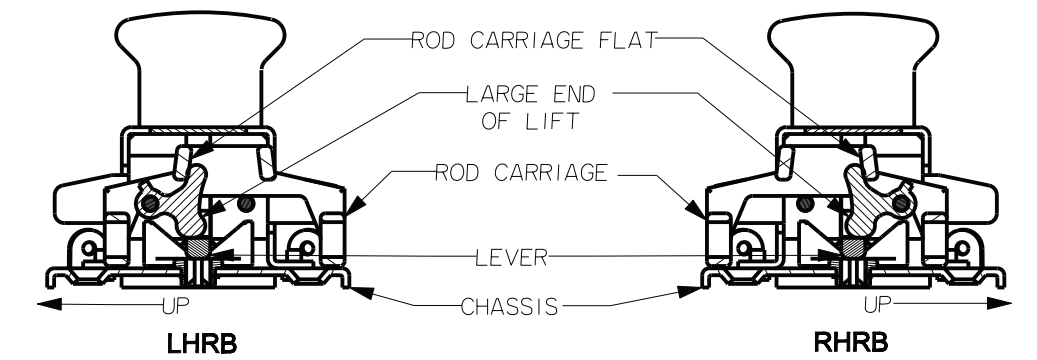
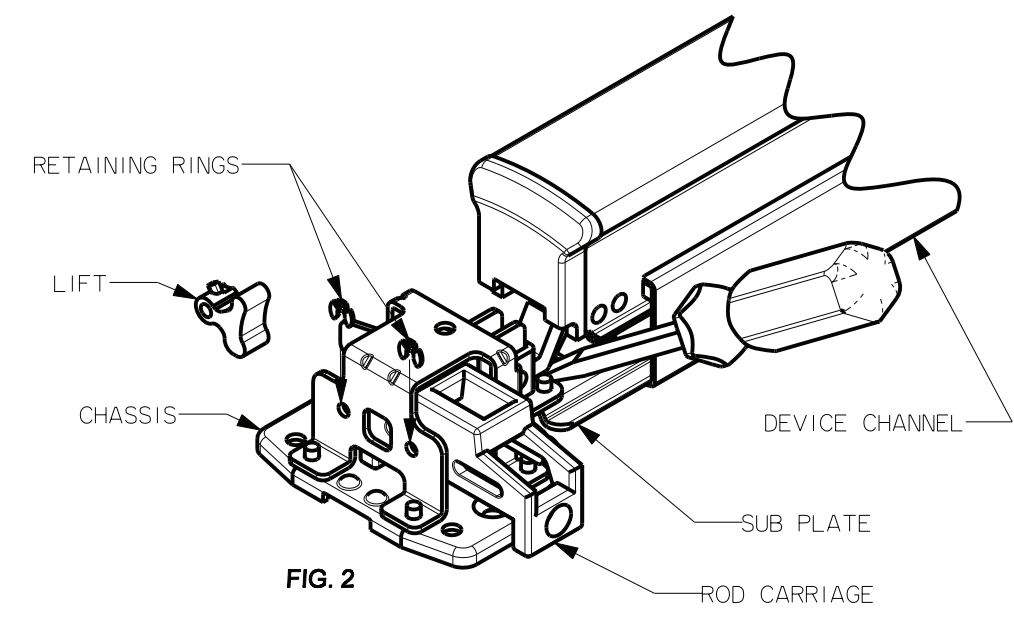

DEVICE PREPARATION

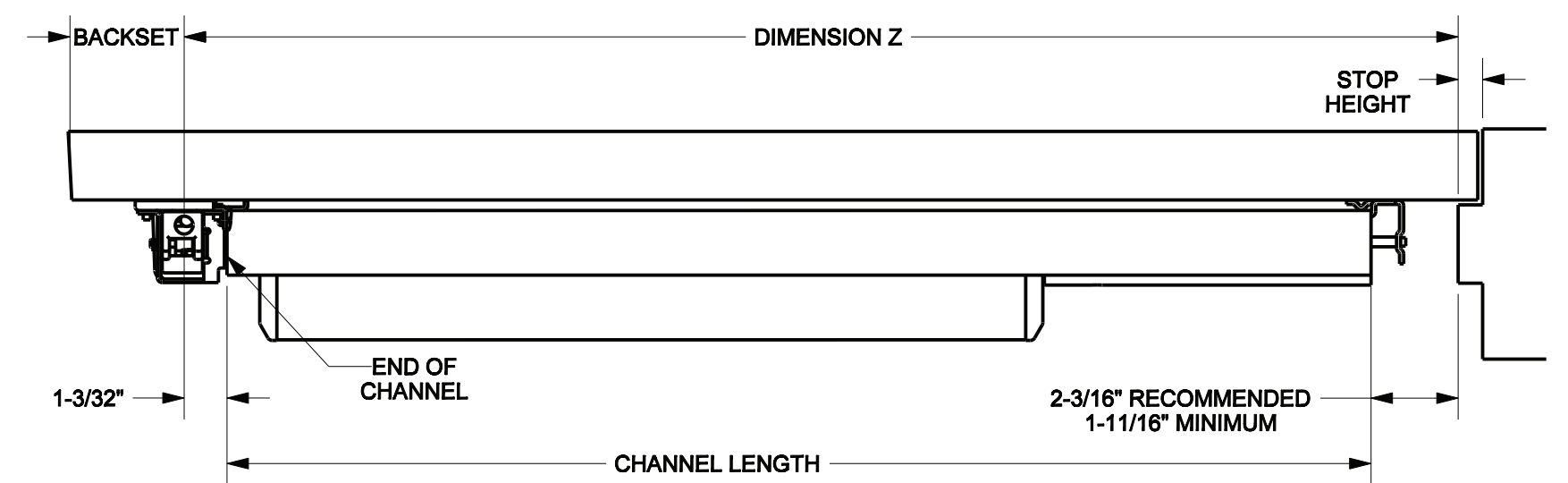

- CUT DEVICE: - If Required**
1. Determine proper **CHANNEL LENGTH** by subtracting 3 1/4" from dimension **Z**.
 2. Mark cut off point (hinge side filler must be all the way inside of channel).
 3. Cut off channel and hinge side filler and deburr.

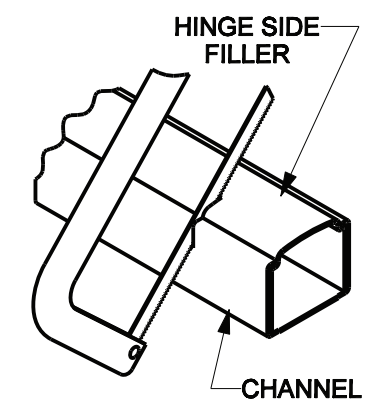

- CAUTION -
PROTECT INSIDE OF DEVICE FROM METAL SHAVINGS

BOTTOM STRIKE SCREWS/ANCHORS	QTY.
1/4-20 x 1/2", FLAT HEAD MS	2
#14 X 1", FLAT HEAD SMS	2
ANCHOR, PLASTIC PLUG	2
DROP-IN ANCHOR, 1/4-20	2

1 DOOR PREPARATION

1. Circle the **TRIM NUMBER** (if specified) at various locations (holes B and C) on the **TRIM TEMPLATE**.
2. Mark **HORIZONTAL CENTERLINE** on inside face of door 40-5/16" from finished floor as shown. (Continue horizontal centerline to outside face of door if Trim is specified).
3. Mark **VERTICAL CENTERLINE** per **BACKSET** indicated at lock side on full height of door and carry it onto the under side of the **DOOR STOP**. (If trim is specified mark vertical centerline at lock side using Backset dimension on outside face of door).

CAUTION: Vertical centerlines on both sides of the door should be the same dimension from the edge of the door.

4. Tape **LOCK STILE CASE**, **TOP LATCH** and **BOTTOM LATCH** (and Trim Template if Trim specified) to the door so that the centerlines on the Template line up with centerlines on the door. Mark centers and drill the required holes as indicated on the templates.

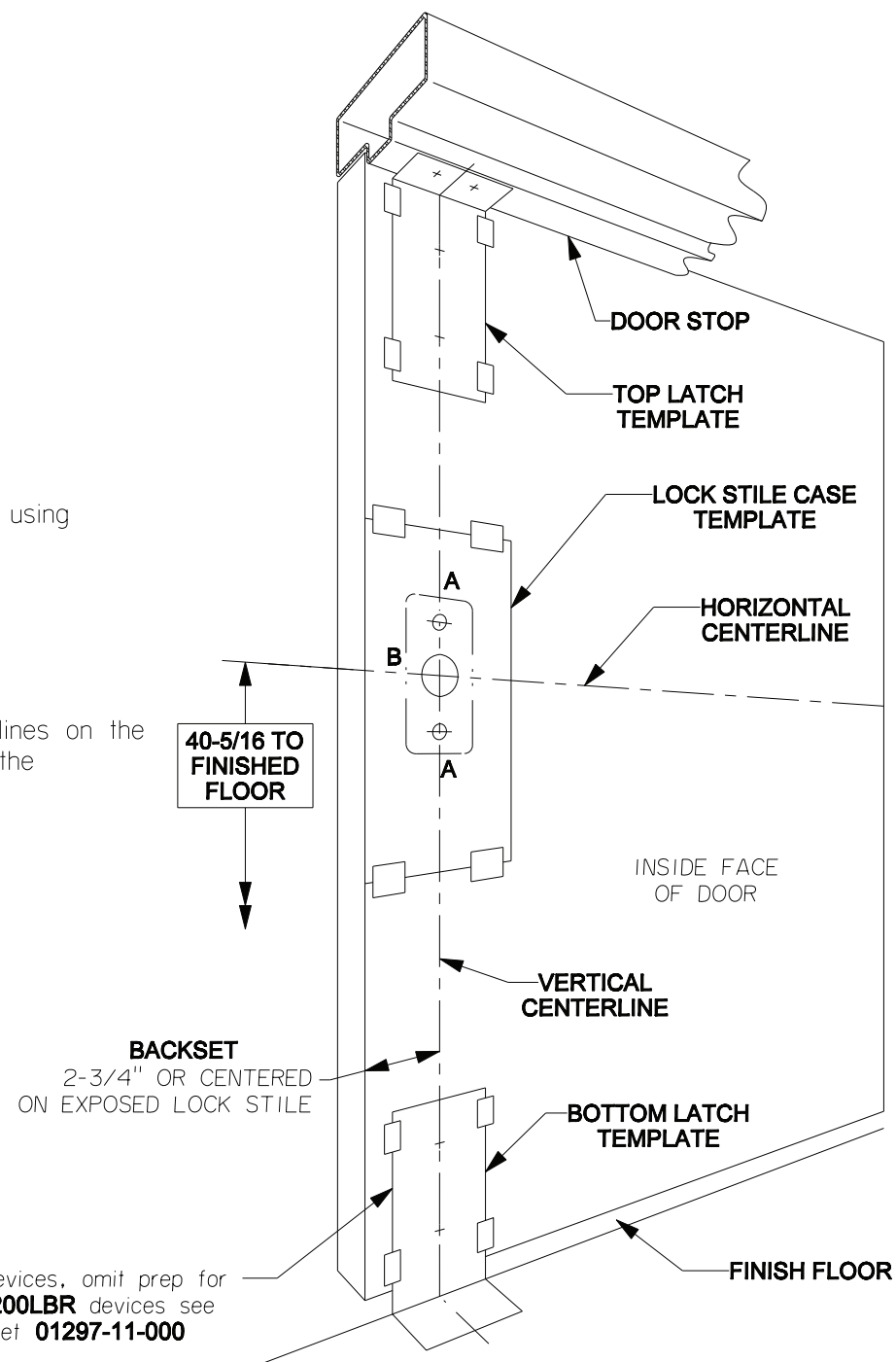

2 APPLY DEVICE

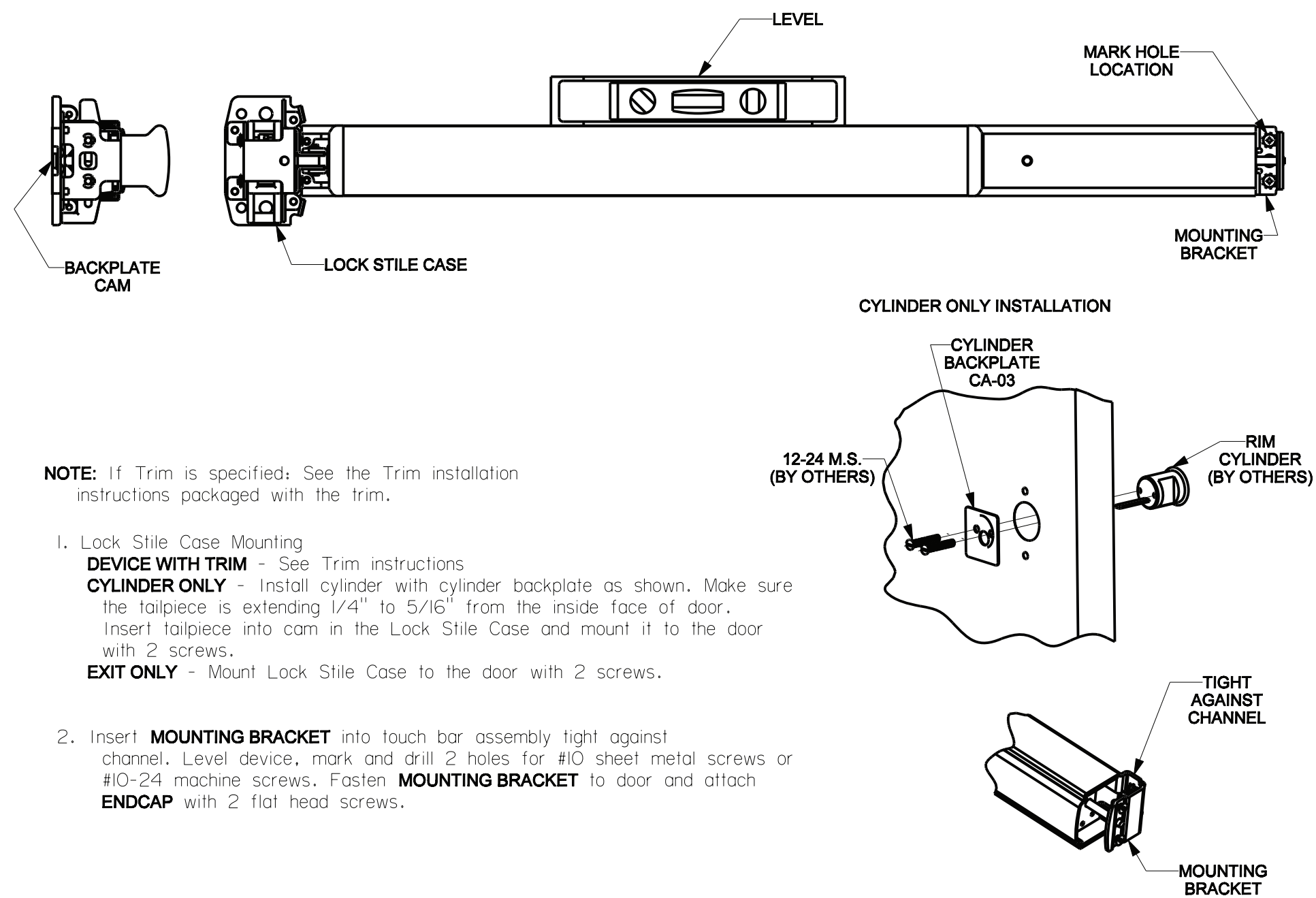

1. Lock Stile Case Mounting
DEVICE WITH TRIM - See Trim instructions
CYLINDER ONLY - Install cylinder with cylinder backplate as shown. Make sure the tailpiece is extending 1/4" to 5/16" from the inside face of door. Insert tailpiece into cam in the Lock Stile Case and mount it to the door with 2 screws.
EXIT ONLY - Mount Lock Stile Case to the door with 2 screws.
2. Insert **MOUNTING BRACKET** into touch bar assembly tight against channel. Level device, mark and drill 2 holes for #10 sheet metal screws or #10-24 machine screws. Fasten **MOUNTING BRACKET** to door and attach **ENDCAP** with 2 flat head screws.

3 APPLY LATCHES AND RODS

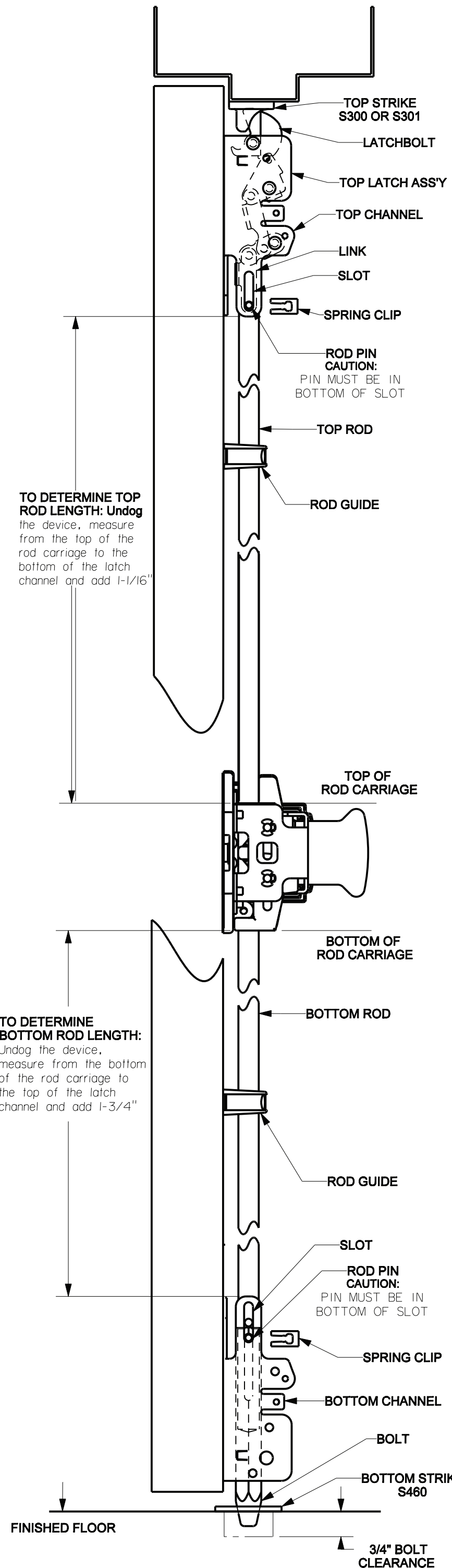

1. Mount top latch assembly with (2) 1/4-20 MS pan head screws or #14 X 1 SMS.
2. Fasten top strike to frame with 2 screws and star washers. Adjust strike so that device latches without binding. Strike shims are provided if an excessive gap is apparent between latchbolt and strike. Apply third screw in center hole of strike once adjustment is complete.
3. Determine rod lengths as shown. Cut rod if necessary: Cut end of rod with holes; NOT THE THREADED END. Drill 3/16 diameter hole thru rod. See ILLUSTRATION 1.
4. With rod carriage down, thread top rod into rod carriage until hole in top rod aligns with bottom of slot in top channel. Pull link down so the hole in the link is at the bottom of the slot in the channel. Insert rod pin thru channel, link and rod. Push spring clip onto rod pin until it snaps into place.
 - A. Pushing on touchbar will retract the latchbolt and open the door. Latch will stay retracted and device is in **HOLDBACK**.
 - B. If no holdback: Remove spring clip and rod pin. Turn rod counter clockwise one half turn, insert rod pin and check holdback. Repeat if necessary.
 - C. When top latch is in the holdback, extend latchbolt by rotating it. Fully extended latchbolt should be in **DEADLOCK**. Latchbolt can not be pushed down into the latch channel.
 - D. If no deadlock: Remove rod pin. Turn rod clockwise one half turn, insert rod pin and check deadlock. Repeat if necessary and install spring clip.
5. For "LBR" devices attach latch and lock stile case covers.
6. Mount bottom channel with (2) 1/4-20 pan head screws or #14 X 1 SMS.
7. With the rod carriage down, thread the bottom rod into the rod carriage until the appropriate hole (see ILLUSTRATION 1 below) in the rod aligns with bottom of slot in the bottom channel, insert rod into the bolt by lifting it up. Insert rod pin thru channel, bolt and then rod.
8. Place device in holdback by pushing on touchbar. Clearance between the bottom of the bolt and the surface where strike will be mounted should be **1/4"**. If clearance is not **1/4"**, remove rod pin and thread rod into the rod carriage to achieve **1/4"** clearance. Install rod pin and spring clip.
- 9A. **FOR FLOOR APPLICATION:** Center strike around bolt. Mark floor for fasteners, prepare floor according to the type of fastener furnished. Provide clearance in floor for bolt.
- 9B. **FOR THRESHOLD APPLICATION:** Center strike around bolt. Provide hole in threshold to accept the bolt. Mark threshold for fasteners. Prepare the threshold according to type of fasteners furnished.
10. Position rod guides midway between latches and lock stile case, centered on rods. Mark, drill and fasten guides with 2 screws.
11. Attach all covers with screws.

