

# OMNILOCK®

## Adaptation Instructions for Omnilock OMEM-M with Schlage L-series Locks

### Planning the installation

#### Contents

These adaptation instructions describe how to install your OMEM-M Omnilock with a Schlage L-series Mortise Lock. Topics covered include:

*Planning the installation*.....1  
*Installing the lock*.....3  
*Testing the lock*.....5

#### Site survey

Use the following survey to record information about the installation site. You need this information to determine how to prepare the door for the lock.

#### Door information

Door handing and bevel:

If a handing change is required, see the Schlage instruction sheet.

- Left hand (LH)
- Left hand, reverse bevel (LHRB)
- Right hand (RH)
- Right hand, reverse bevel (RHRB)

Door thickness: Check your Schlage instruction sheet for proper door thickness.

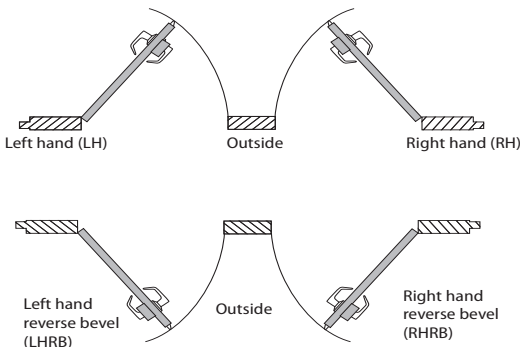

Figure 1 Door handing chart

#### Components checklist

Use the following checklist to make sure that you have the items necessary to install your OMEM-M Mortise Lock.

#### Components provided in the box:

- Outside escutcheon assembly
- Back plate with hardware
- Batteries

#### Other components:

- Programming Default ID Card (provided with software)
- Schlage L-series mortise lock from manufacturer

#### Environment information

Model	Side of door	Temperature Range	Exposure
Standard	Outside	+32°F to +129°F 0°C to +54°C	Drip proof. Inadvertent splashing of water spray acceptable.
Weatherized	Outside	-4°F to +129°F -20°C to +54°C	Direct exposure to rain and snow

## Planning the installation

For hole sizes, see Installation Template for OMEM-M Mortise Locks OM-12 (T83348)

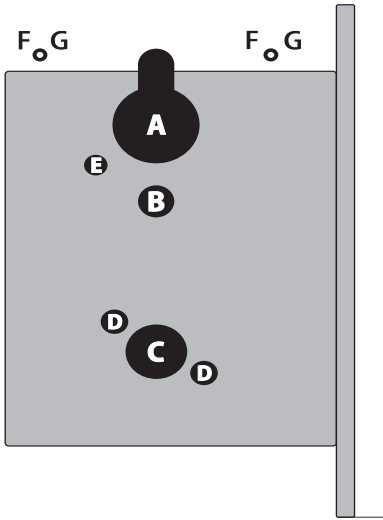

Figure 2 Identifying holes to drill

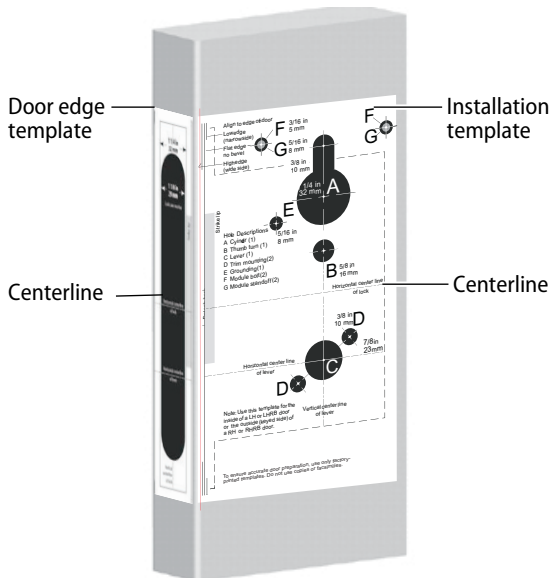

Figure 3 Aligning the templates

### 1 Additional holes to drill

**Note:** Use the Schlage instructions for drilling holes A through D.

- 1 Determine the inside and outside of the door.
- 2 See the table below and Figure 1 to determine which side of the door the holes will be drilled.

Door side	Inside	Outside
<b>E</b> Grounding hole		■
<b>F</b> Through bolt hole	Through door	
<b>G</b> Standoff hole		■

### 2 Position template and mark drill points

**Note:** If the door is a fabricated hollow metal door, determine whether it is properly reinforced to support the lock. If door reinforcement is not adequate, consult the door manufacturer for information on proper reinforcement.

- 1 Separate the templates provided on the Installation Template for OMEM-M Mortise Locks OM-12 (T83348)
- 2 Position one of the door edge templates on the door, making sure that the lock case mortise shown on the template aligns with the mortise pocket prepared in the door.
- 3 Using the centerlines on the door edge templates as guides, position the appropriate door template on each side of the door. You need to take the bevel into account. Tape the templates to the door.

## Installing the lock

### 3 Center punch and drill holes

- 1 Center punch the necessary drill points. See the instructions on the template.
- 2 Drill the holes.

### 4 Install mortise case

**Note:** Use the Schlage instructions for installing the mortise, thumb turn, levers, and/or the strike box.

### 5 Install batteries

Four alkaline AA batteries (or two weatherized packs if installing a weatherized unit) are furnished with your Omnilock system and must be installed before proceeding with operation verification and system installation.

- 1 Remove the gasket from the rear of the housing assembly as shown in Figure 4.
- 2 Remove the screw from the battery cover and remove the cover.
- 3 Install batteries with proper polarity as shown in Figure 5. (For weatherized battery packs, simply connect the wires from the battery pack to the circuit board as shown in Figure 6.)

**Note:** Be sure red and black motor wires are connected before attempting step 4. Align the wires together so that the wire colors match.

- 4 Press and hold the reset button on the PC board (as shown in Figure 5) until the green light on the keypad flashes (about three seconds) then release the button. If green light does not flash, see "Troubleshooting" on page 5.
- 5 Replace the battery cover. See Figure 4. Make sure that the tabs on the lower edge of the battery cover are hooked over the edge of the back plate and secure the cover with the screw.
- 6 Replace the gasket. See Figure 4. Make sure that it is inside the edge of the housing.

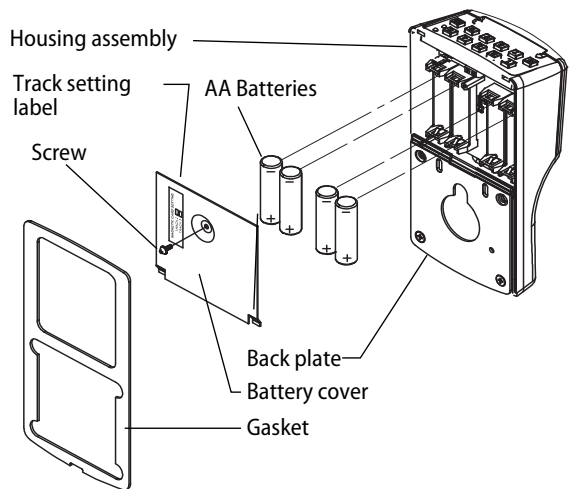

Figure 4 Installing batteries

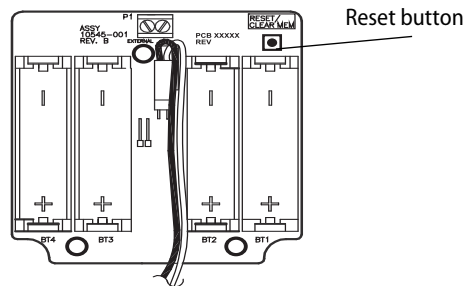

Figure 5 Using the reset button

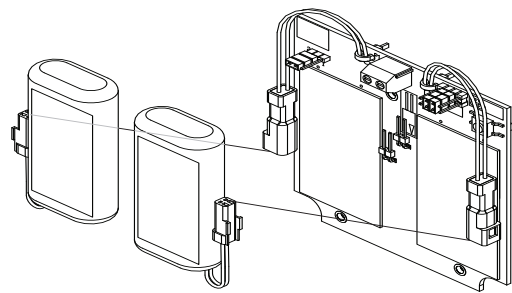

Figure 6 Installing weatherized batteries

## Installing the lock

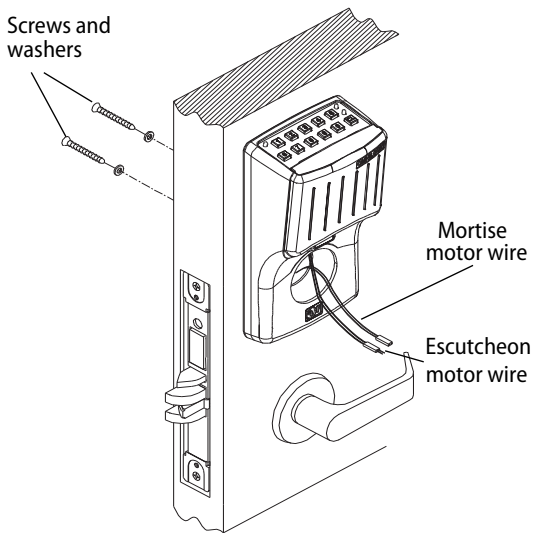

Figure 7 Installing the outside escutcheon

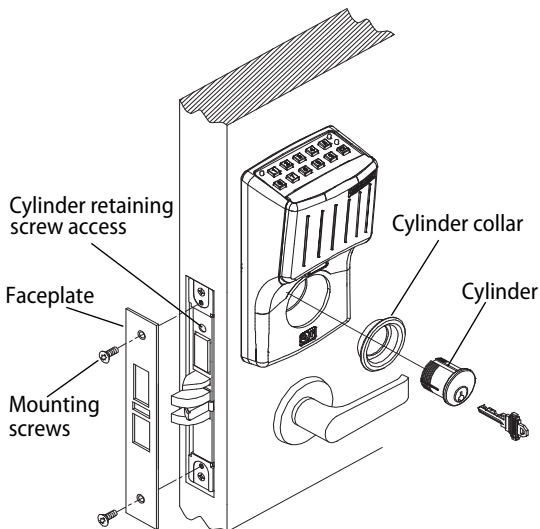

Figure 8 Installing the standard cylinder

### 6 Install outside escutcheon

- 1 Ensure that no wires are pinched when attaching the escutcheon to the door.
- 2 Insert the standoffs and grounding spring into the predrilled holes. Use provided screws and washers to attach the escutcheon from the inside of the door.
- 3 Connect the red and black motor wire from the mortise case to the red and black escutcheon motor wire. **Align the wires so that the wire colors match.**
- 4 **(Optional)** Connect the yellow Key Override Switch (KOS) wires of the escutcheon wiring harness to the corresponding wires on your mortise case. Polarity on the KOS wires is not an issue.

### 7 Install cylinder and faceplate

- 1 Push any excess wire into the escutcheon housing. Make sure no wires are pinched.
- 2 Make sure cylinder collar provided in the OMEM-M kit is positioned on the cylinder.
- 3 Thread the cylinder into the mortise case until the cylinder is almost flush against the collar. Position the cylinder core in the 6 o'clock position. See Figure 8.

**Caution: A malfunction can occur if the cylinder is threaded in too far.**

- 4 With the cylinder vertical as in Figure 8, tighten the cylinder retaining screw.
- 5 Secure the mortise case faceplate to the mortise case with the faceplate mounting screws.
- 6 Check the lock for proper operation.

## Testing the lock

### 8 Check operation

Check the operation of the lock. For example, check that:

- door latches and opens properly
- deadbolt, if available, operates properly
- key access works
- door gap is not more than 1/8" (3 mm)

For assistance, contact your local dormakaba Omnilock dealer.

### 9 Test lock

To test the lock for proper operation before the lock is programmed, follow these instructions:

#### For keypad locks

- 1 Press **1234 for the 2000 series, or 5011234 for the 500 series.**

*The green light flashes and the latch unlocks.*

- 2 Turn the lever and open the door.

*During the unlock time, the green light flashes. Then the red light flashes and the latch relocks.*

#### For magnetic stripe card locks

- 1 Align the magnetic stripe card with the V mark by the card slot.

- 2 Insert and then remove the card.

*The green light flashes and the latch unlocks.*

- 3 Turn the lever and open the door.

*During the unlock time, if using the Programming Default ID Card, the green light flashes. Then the red light flashes and the latch relocks.*

#### For proximity card locks

- 1 Align the proximity card over the recess on the front of the escutcheon.

*The green light flashes and the latch unlocks.*

- 2 Turn the lever and open the door.

*During the unlock time, if using the Programming Default ID Card, the green light flashes. Then the red light flashes and the latch relocks.*

### 10 Troubleshooting

If the mechanism does not unlock, remove the battery cover and check for proper orientation and seating of the batteries and motor connector. Ensure that wires are not pinched. Reset the electronics by pressing and holding the reset button on the circuit board until the light flashes green (approximately 3 seconds), then releasing the button. See Figure 9.

**Note:** *The system will go through a self-test and the green light will flash five times. You will hear the lock unlock, then relock three times. A red flash indicates a PC board or drive system problem. If a red flash or no flash is observed, check for proper orientation and seating of the batteries and motor connector, ensure that wires are not pinched, then repeat the reset process.*

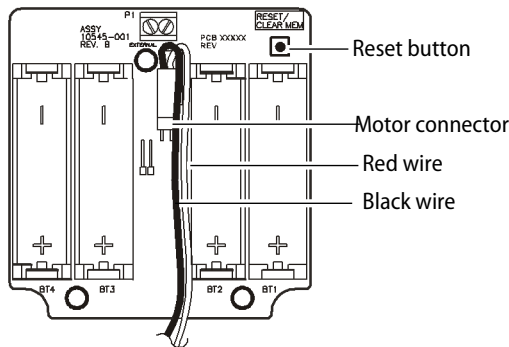

Figure 9 Using the reset button





