

6K SERIES

SERVICE MANUAL

**6K GRADE 2
CYLINDRICAL LOCKS**

CREDITS/COPYRIGHT

Copyright ©2021 dormakaba USA Inc. All rights reserved.

Information in this document is subject to change without notice and does not represent a commitment on the part of dormakaba USA Inc. The software described in this document are furnished under a license agreement or nondisclosure agreement.

This publication is intended to be an accurate description and set of instructions pertaining to its subject matter. However, as with any publication of this complexity, errors or omissions are possible. Please call dormakaba USA Inc. at 1-800-392-5209 if you see any errors or have any questions. No part of this manual and/or databases may be reproduced or transmitted in any form or by any means, electronic or mechanical, including photocopying, recording, or information storage and retrieval systems, for any purpose, without the express written permission of dormakaba USA Inc.

This document is distributed as is, without warranty of any kind, either express or implied, respecting the contents of this book, including but not limited to implied warranties for the publication's quality, performance, merchantability, or fitness for any particular purpose. Neither dormakaba USA Inc., nor its dealers or distributors shall be liable to the user or any other person or entity with respect to any liability, loss, or damage caused or alleged to be caused directly or indirectly by this publication.

Written and designed by:
dormakaba USA Inc.
6161 East 75th Street
Indianapolis, IN 46250

T56080_Rev D 1798060 ER-7991-6 August 2021

CONTENTS

FIGURES VII

GETTING STARTED 1-1

- Introduction 1-1
- Certifications and standards 1-1
- Documentation package 1-1
- Technical support 1-2
 - Support services 1-2
 - Telephone technical support 1-2

FUNCTIONS AND PARTS LISTS 2-1

- Function descriptions 2-2
 - Single-keyed functions 2-2
 - Non-keyed functions 2-4
 - Special functions 2-5
 - Functions by ANSI designation 2-5
- Exploded diagrams and parts lists 2-6
 - AB function—entrance lock [ANSI F109] 2-6
 - B function—entrance lock [ANSI F82] 2-7
 - D function—storeroom lock [ANSI F86] 2-8
 - E function—service station lock [ANSI F92] 2-9
 - L function—privacy lock [ANSI F76] 2-10
 - LL function—hospital privacy 2-11
 - N function—passage lock [ANSI F75] 2-12
 - P function—patio lock [ANSI F77] 2-13
 - R function—classroom lock [ANSI F84] 2-14
 - Y function—exit lock 2-15

Function conversion	2-16
Trim parts	2-17
Strikes and strike boxes	2-17
Roses and rose liners	2-18
Knobs and throw member	2-19
Dummy trim	2-20
Latches and latch tube sleeve	2-21
Tools	2-22

SERVICE AND MAINTENANCE 3-1

Replacing parts	3-2
Replacing the core and throw member	3-2
Replacing the knob	3-3
Replacing the button assembly	3-4
Replacing the bearing	3-6
Replacing the inside rose and rose liner	3-7
Replacing the outside rose and liner assembly	3-8
Replacing the lock chassis assembly	3-9
Lubricating the core	3-10
Aligning the chassis and trim	3-11
Troubleshooting	3-12

INSTALLATION INSTRUCTIONS A-1

INDEX B-1

FIGURES

FUNCTIONS AND PARTS LISTS

- [Understanding function drawings](#) 2-2
- [Strikes and strike boxes](#) 2-17
- [Roses and rose liners](#) 2-18
- [Knobs](#) 2-19
- [Throw member and spacer](#) 2-19
- [Dummy trim parts](#) 2-20
- [Latches](#) 2-21
- [Latch tube sleeve](#) 2-22
- [Installation tools](#) 2-22
- [Boring jig kit](#) 2-23

SERVICE AND MAINTENANCE

- [Removing and reinstalling the core](#) 3-2
- [Removing the knob](#) 3-3
- [Reinstalling the non-keyed knob](#) 3-3
- [Reinstalling the keyed knob](#) 3-4
- [Removing the button assembly](#) 3-4
- [Reinstalling the outside button assembly](#) 3-5
- [Reinstalling the inside button assembly](#) 3-5
- [Removing the bearing](#) 3-6
- [Reinstalling the bearing](#) 3-6
- [Removing the inside rose and rose liner](#) 3-7
- [Reinstalling the inside rose and rose liner](#) 3-8
- [Removing the outside rose and liner assembly](#) 3-8

Figures

Reinstalling the outside rose and liner assembly 3-9

Engaging the retractor in the latch 3-10

Engaging the retractor in the latch 3-11

1

GETTING STARTED

INTRODUCTION

The *6K Series Service Manual* contains essential information to help you maintain your 6K Series Lock.

CERTIFICATIONS AND STANDARDS

- The locks comply with ANSI A156.2, Series 4000 Grade 2 standards.
- The locks are listed by Underwriter's Laboratories for use on 3 Hr., A label single swinging doors [4' x 8'].
- The 8KS3 strike fits the standard door frame cutout as specified in ANSI A115.2.

DOCUMENTATION PACKAGE

The following documentation is available to help you with the installation, start-up, and maintenance of your 6K Series Lock.

The installation and assembly instructions also can be ordered separately:

Document Title	Doc. No.
<i>Installation Instructions for 6K Cylindrical Locks</i> [†]	T56061
<i>Installation Instructions for 6K Dummy Trim</i>	T80943

[†]. These installation instructions are included in this manual. See *Installation Instructions* on [page A-1](#).

The templates required for lock installations also can be ordered separately:

Document Title	Doc. No.
<i>K01 Template for Door and Frame Preparation for 62K Locks with Small [STK] Strike</i>	T56050
<i>K07 Template for Door and Frame Preparation for 62K Locks with Large [S3] Strike</i>	T56051
<i>K08 Template for Door and Frame Preparation for 63K, 73KC, 83K & 93K Locks with Small [STK] Strike</i>	T56052
<i>K09 Template for Door and Frame Preparation for 63K, 73KC, 83K & 93K Locks with Large [S3] Strike</i>	T56053
<i>K10 Template for Door and Frame Preparation for 64K, 84K & 94K Locks with Small [STK] Strike</i>	T56054
<i>K11 Template for Door and Frame Preparation for 64K, 84K, 94K Locks with Large [S3] Strike</i>	T56055
<i>K12 Template for Door and Frame Preparation 65K, 85K & 95K Locks with Small [STK] Strike</i>	T56056
<i>K13 Template for Door and Frame Preparation for 65K, 85K & 95K Locks with Large [S3] Strike</i>	T56057
<i>Template for 6K Dummy Trim</i>	T80944

TECHNICAL SUPPORT

Support services

When you have a question about the 6K Series Lock, your first resource for help is the *6K Series Service Manual*. If you cannot find a satisfactory answer, contact your local dormakaba Representative.

Telephone technical support

A factory-trained Certified Product Specialist (CPS) is available in your area whenever you need help. Before you call, however, please make sure that the product is in your immediate vicinity, and that you are prepared to give the following information:

- what happened and what you were doing when the problem arose
- what you have done so far to correct the problem.

dormakaba USA Inc. representatives provide telephone technical support for all B Series products. You may locate the representative nearest you by calling (800) 392-5209 Monday through Friday, between 8:00 a.m. and 5:00 p.m. eastern standard time; or visit the web page, <https://dhwsupport.dormakaba.com/hc/en-us>.

dormakaba holds training sessions for its customers. The seminars are specifically designed for dormakaba end-users who have a registered a dormakaba [BEST branded product] masterkeyed system and registered a dormakaba [BEST branded product] security equipment. If you are interested, you may contact your local dormakaba representative for details.

2

FUNCTIONS AND PARTS LISTS

The following pages contain function descriptions for all 6K Series Locks. This chapter also includes exploded diagrams that show all field serviceable mechanical parts, diagrams of trim and other miscellaneous parts, and function conversion information.

FUNCTION DESCRIPTIONS

This section includes function descriptions grouped by the following function types:

- single-keyed (page 2–2)
- non-keyed (page 2–4)
- special (page 2–5)
- ANSI designation (page 2–5).

Note: If the function is ANSI defined, the ANSI designation appears by the function name.

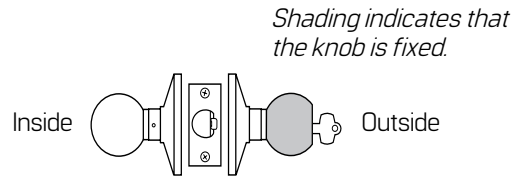
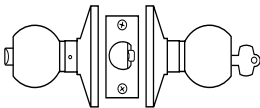

Figure 2.1 Understanding function drawings

Single-keyed functions

The following lists describe how the latchbolt, outside knob, and inside knob operate for each single-keyed 6K function.

AB–Entrance (ANSI F109)



Latchbolt operated by:

- inside knob
- outside key
- outside knob when the inside button is in the unlocked position

Outside knob locked by:

- inside button when pushed in
- inside button when pushed in and rotated clockwise

Outside knob unlocked by:

- inside knob when the inside button is pushed in but not rotated
- outside key when the inside button is pushed in but not rotated
- closing the door when the inside button is pushed in but not rotated

Inside knob is always unlocked

D–Storeroom (ANSI F86)

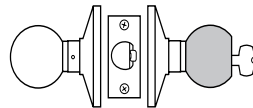

Latchbolt operated by:

- inside knob
 - outside key
- Outside knob is always fixed**
- Inside knob is always unlocked**

E–Service Station (ANSI F92)

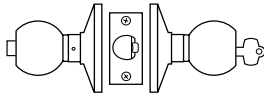

Latchbolt operated by:

- inside knob
- outside key
- outside knob when the inside button is in the unlocked position

Outside knob locked by:

- inside slotted button
- inside slotted button when pushed in and rotated clockwise

Outside knob is unlocked by:

- inside knob
- inside slotted button when rotated counterclockwise
- outside key
- closing the door when the inside button is pushed in but not rotated

Inside knob is always unlocked

R–Classroom (ANSI F84)

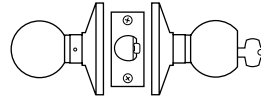

Latchbolt operated by:

- inside knob
- outside key
- outside knob when not locked

Outside knob locked by:

- outside key

Outside knob unlocked by:

- outside key

Inside knob is always unlocked

Non-keyed functions The following lists describe how the latchbolt, outside knob, and inside knob operate for each non-keyed 6K function.

L-Privacy (ANSI F76)

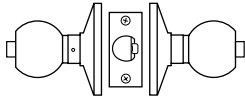

Latchbolt operated by:

- inside knob
- outside knob when the inside button is in the unlocked position

Outside knob locked by:

- inside button

Outside knob unlocked by:

- inside knob
- outside slotted button when pushed in and rotated counter-clockwise
- closing the door

Inside knob is always unlocked

N-Passage (ANSI F75)

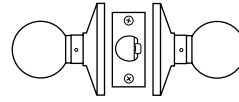

Latchbolt operated by:

- inside knob
- outside knob

Outside knob is always unlocked

Inside knob is always unlocked

Y-Exit

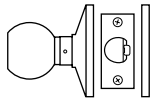

Latchbolt operated by:

- inside knob

Inside knob is always unlocked

P-Patio (ANSI F77)

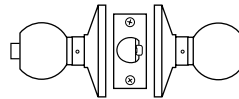

Latchbolt operated by:

- inside knob
- outside knob when the inside button is in the unlocked position

Outside knob locked by:

- inside button

Outside knob unlocked by:

- inside knob
- closing the door

Inside knob is always unlocked

1DT-Single dummy trim

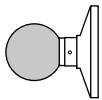

This lock is a single, surface-mounted knob for an inactive door or a non-latching door.

Special functions The following lists describe how the latchbolt, outside knob, and inside knob operate for each special 6K function.

LL–Hospital privacy

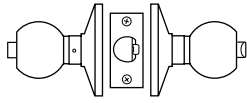

Latchbolt operated by:

- inside knob
- outside knob when not locked

Outside knob locked by:

- inside button

Outside knob unlocked by:

- inside knob
- outside button when pushed in and rotated counterclockwise
- closing the door

Inside knob is always unlocked

B–Office

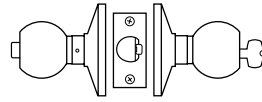

Latchbolt operated by:

- inside knob
- outside key
- outside knob when the inside button is in the unlocked position

Outside knob locked by:

- inside button

Outside knob unlocked by:

- inside knob
- outside key

Inside knob is always unlocked

Functions by ANSI designation	ANSI No.	Function
	F75	N
	F76	L
	F77	P
	F82	B
	F84	R
	F86	D
	F92	E
	F109	AB

EXPLODED DIAGRAMS AND PARTS LISTS AB FUNCTION—ENTRANCE LOCK (ANSI F109)

Item	Part No.	Qty.	Description
1	[see page 2-19]	1	Button knob
2	A80050	1	Turn button assembly
3	[see page 2-18]	1	Rose
4	A80041	2	Chassis screw
5	[see page 2-18]	1	Rose liner
6	B80048	1	Bearing
7	B80105	1	AB function chassis [†]
8	[see page 2-18]	1	Rose and rose liner assembly
9	[see page 2-19]	1	Keyed knob

[†] If you are replacing a chassis, order two trim rings (part number B80004) in addition to the chassis, and indicate the finish. The trim rings must be installed on the chassis at the factory.

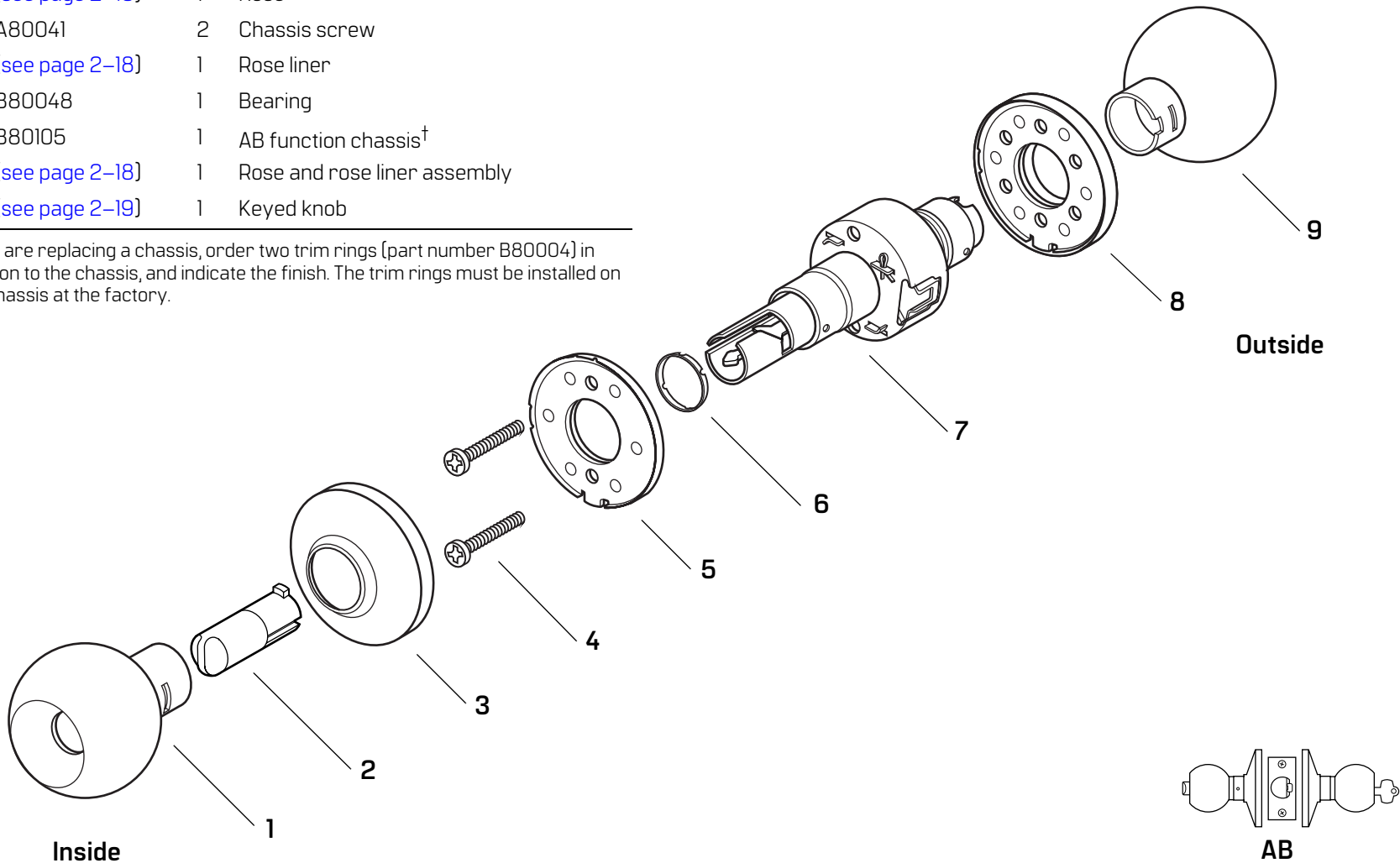

Figure 2.2 AB function exploded diagram

B FUNCTION—ENTRANCE LOCK (ANSI F82)

Item	Part No.	Qty.	Description
1	[see page 2-19]	1	Button knob
2	A80052	1	Push button assembly
3	[see page 2-18]	1	Rose
4	A80041	2	Chassis screw
5	[see page 2-18]	1	Rose liner
6	B80048	1	Bearing
7	B80105	1	AB function chassis†
8	[see page 2-18]	1	Rose and rose liner assembly
9	[see page 2-19]	1	Keyed knob

† If you are replacing a chassis, order two trim rings (part number B80004) in addition to the chassis, and indicate the finish. The trim rings must be installed on the chassis at the factory.

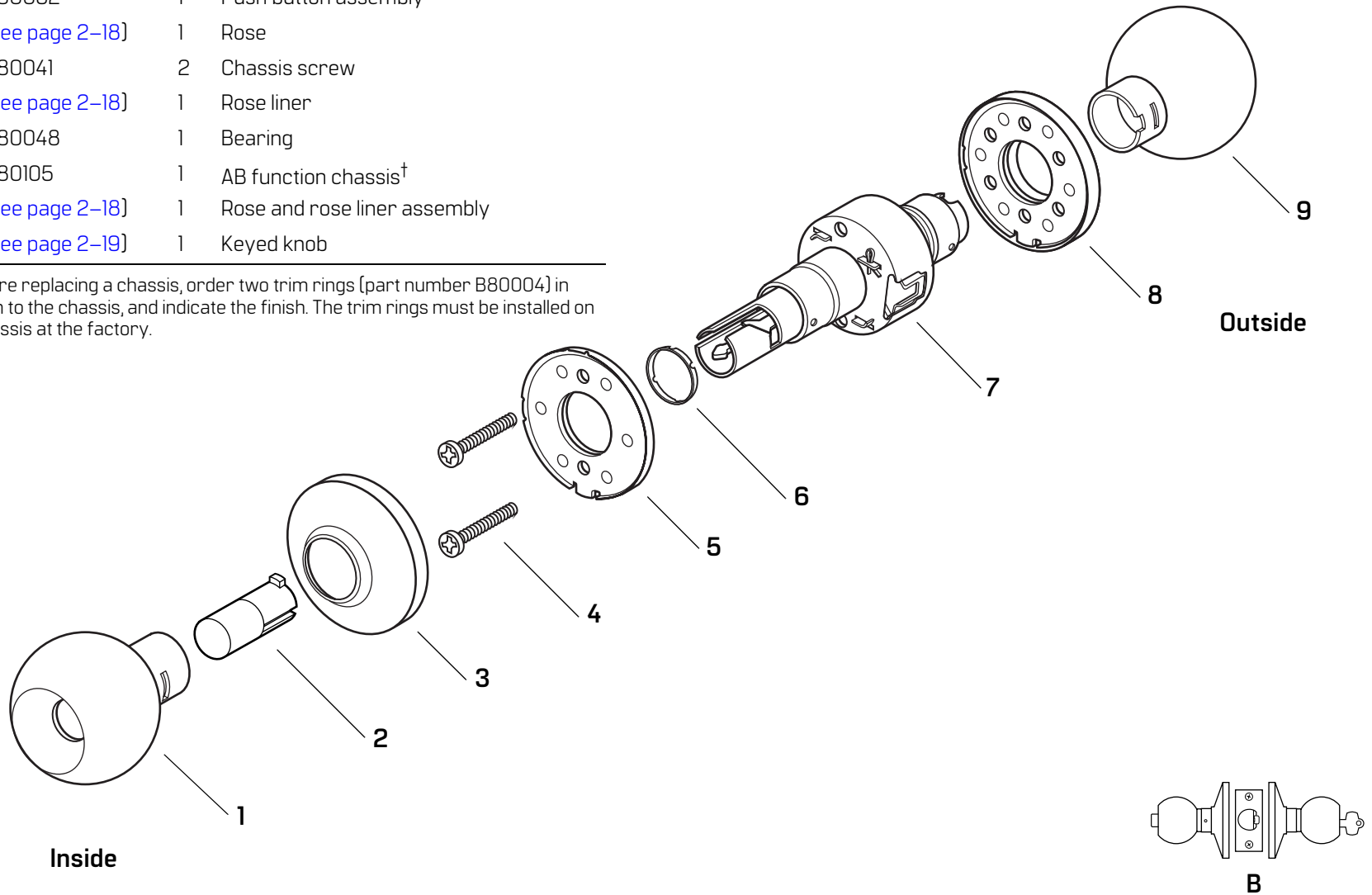

Figure 2.3 B function exploded diagram

D FUNCTION—STOREROOM LOCK (ANSI F86)

Item	Part No.	Qty.	Description
1	[see page 2-19]	1	Plain knob
2	[see page 2-18]	1	Rose
3	A80041	2	Chassis screw
4	[see page 2-18]	1	Rose liner
5	B80048	1	Bearing
6	B80102	1	D function chassis†
7	[see page 2-18]	1	Rose and rose liner assembly
8	[see page 2-19]	1	Keyed knob

† If you are replacing a chassis, order two trim rings (part number B80004) in addition to the chassis, and indicate the finish. The trim rings must be installed on the chassis at the factory.

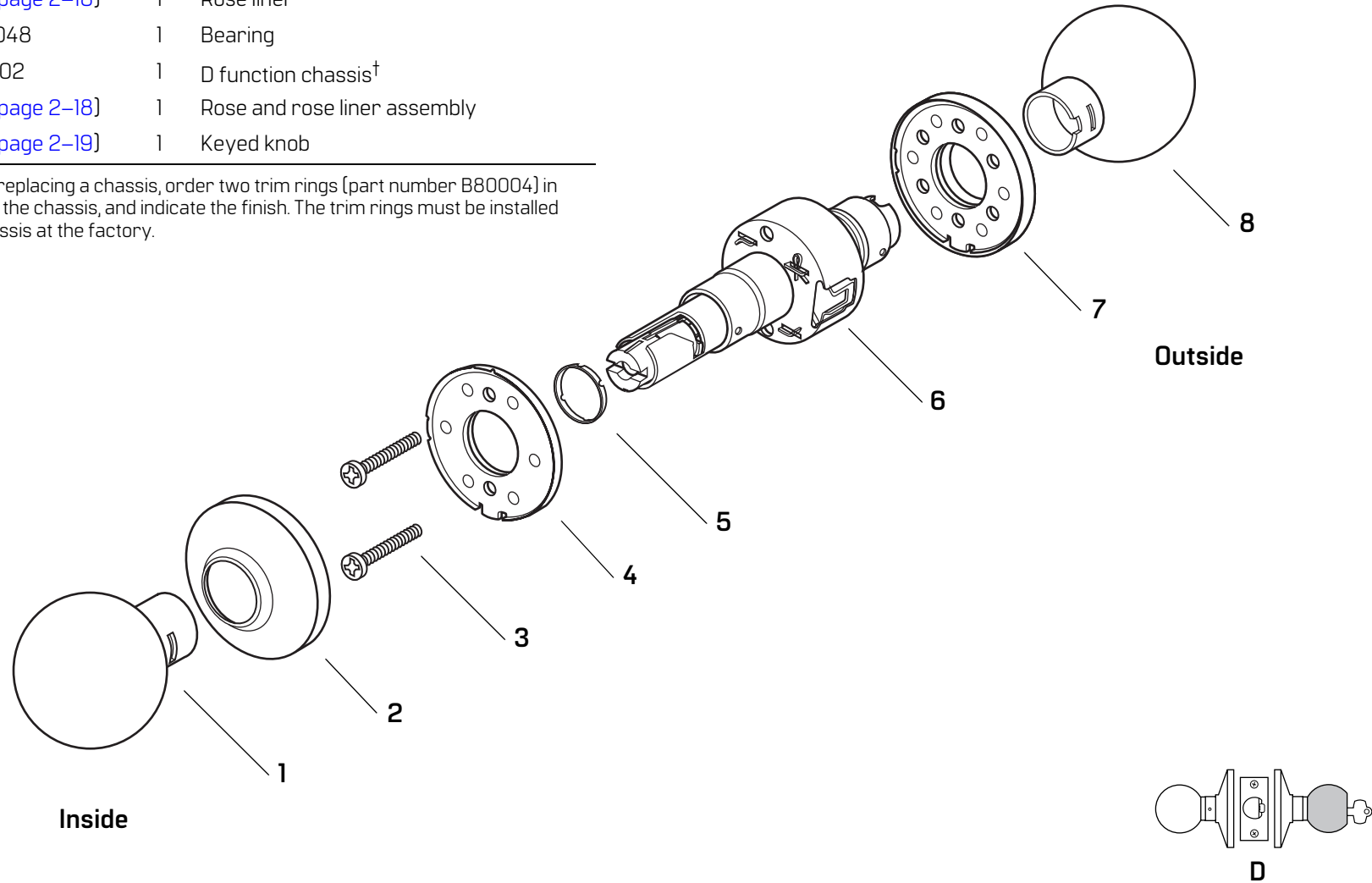

Figure 2.4 D function exploded diagram

E FUNCTION—SERVICE STATION LOCK (ANSI F92)

Item	Part No.	Qty.	Description
1	[see page 2-19]	1	Button knob
2	A80051	1	Slotted button assembly
3	[see page 2-18]	1	Rose
4	A80041	2	Chassis screw
5	[see page 2-18]	1	Rose liner
6	B80048	1	Bearing
7	B80105	1	AB function chassis†
8	[see page 2-18]	1	Rose and rose liner assembly
9	[see page 2-19]	1	Keyed knob

† If you are replacing a chassis, order two trim rings (part number B80004) in addition to the chassis, and indicate the finish. The trim rings must be installed on the chassis at the factory.

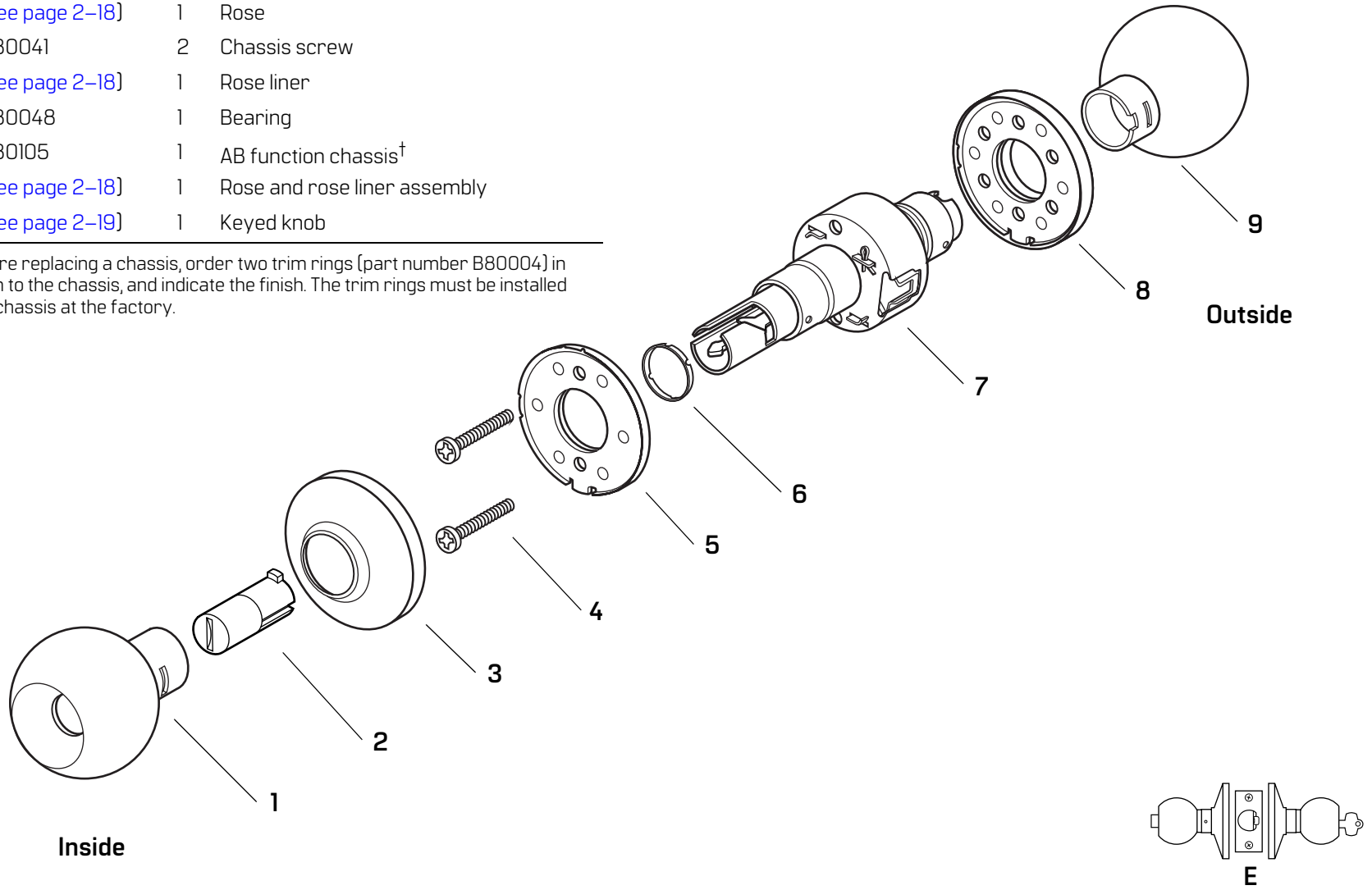

Figure 2.5 E function exploded diagram

L FUNCTION—PRIVACY LOCK (ANSI F76)

Item	Part No.	Qty.	Description
1	[see page 2-19]	1	Button knob
2	A80052	1	Push button assembly
3	[see page 2-18]	1	Rose
4	A80041	2	Chassis screw
5	[see page 2-18]	1	Rose liner
6	B80048	2	Bearing
7	B80105	1	AB function chassis†
8	[see page 2-18]	1	Rose and rose liner assembly
9	A80053	1	Slotted button assembly
10	[see page 2-19]	1	Button knob

† If you are replacing a chassis, order two trim rings (part number B80004) in addition to the chassis, and indicate the finish. The trim rings must be installed on the chassis at the factory.

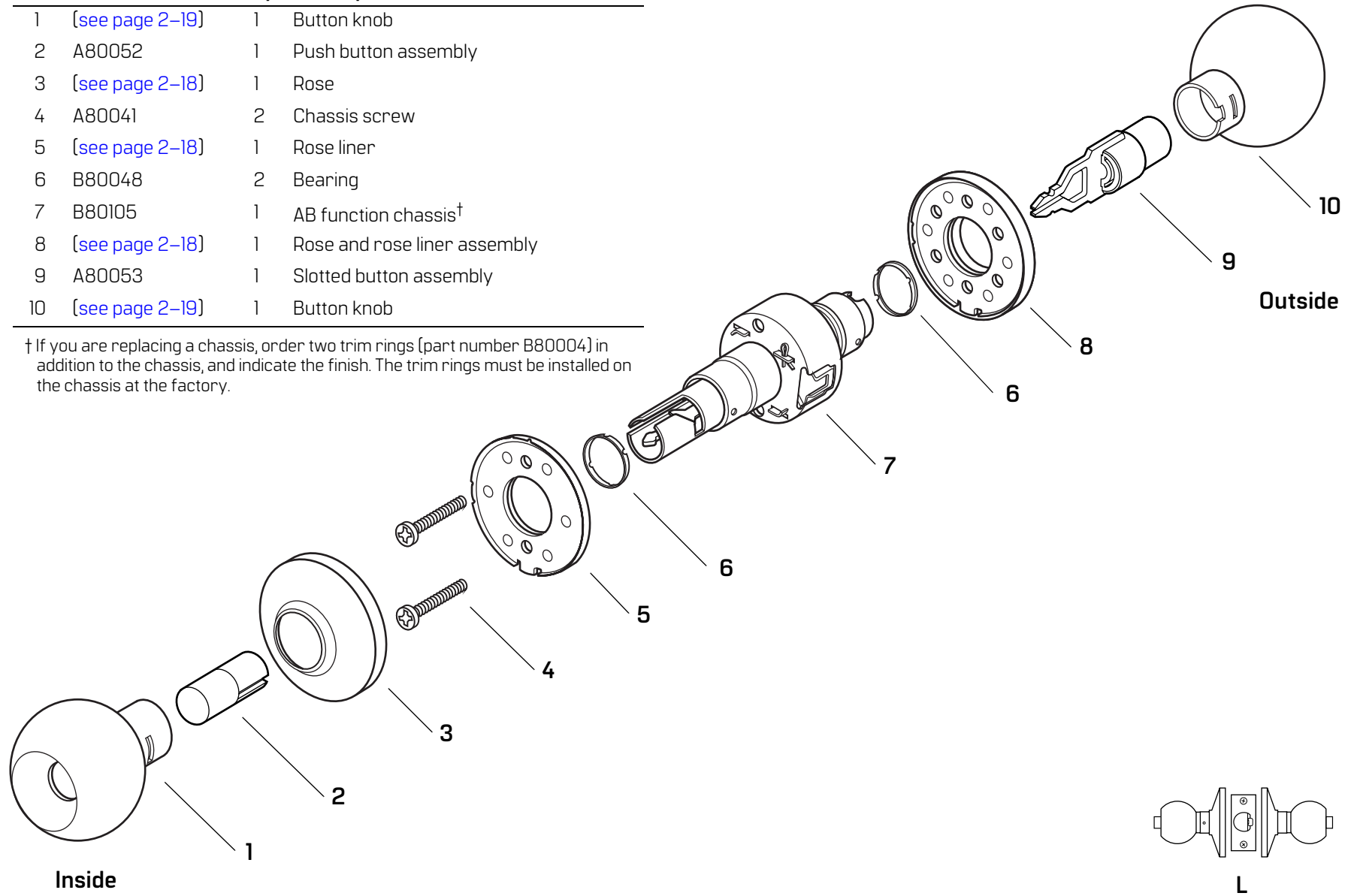

Figure 2.6 L function exploded diagram

LL FUNCTION—HOSPITAL PRIVACY

Item	Part No.	Qty.	Description
1	[see page 2-19]	1	Button knob
2	A80050	1	Push button assembly
3	[see page 2-18]	1	Rose
4	A80041	2	Chassis screw
5	[see page 2-18]	1	Rose liner
6	B80048	2	Bearing
7	B80105	1	AB function chassis†
8	[see page 2-18]	1	Rose and rose liner assembly
9	A80054	1	Turn button assembly
10	[see page 2-19]	1	Button knob

† If you are replacing a chassis, order two trim rings (part number B80004) in addition to the chassis, and indicate the finish. The trim rings must be installed on the chassis at the factory.

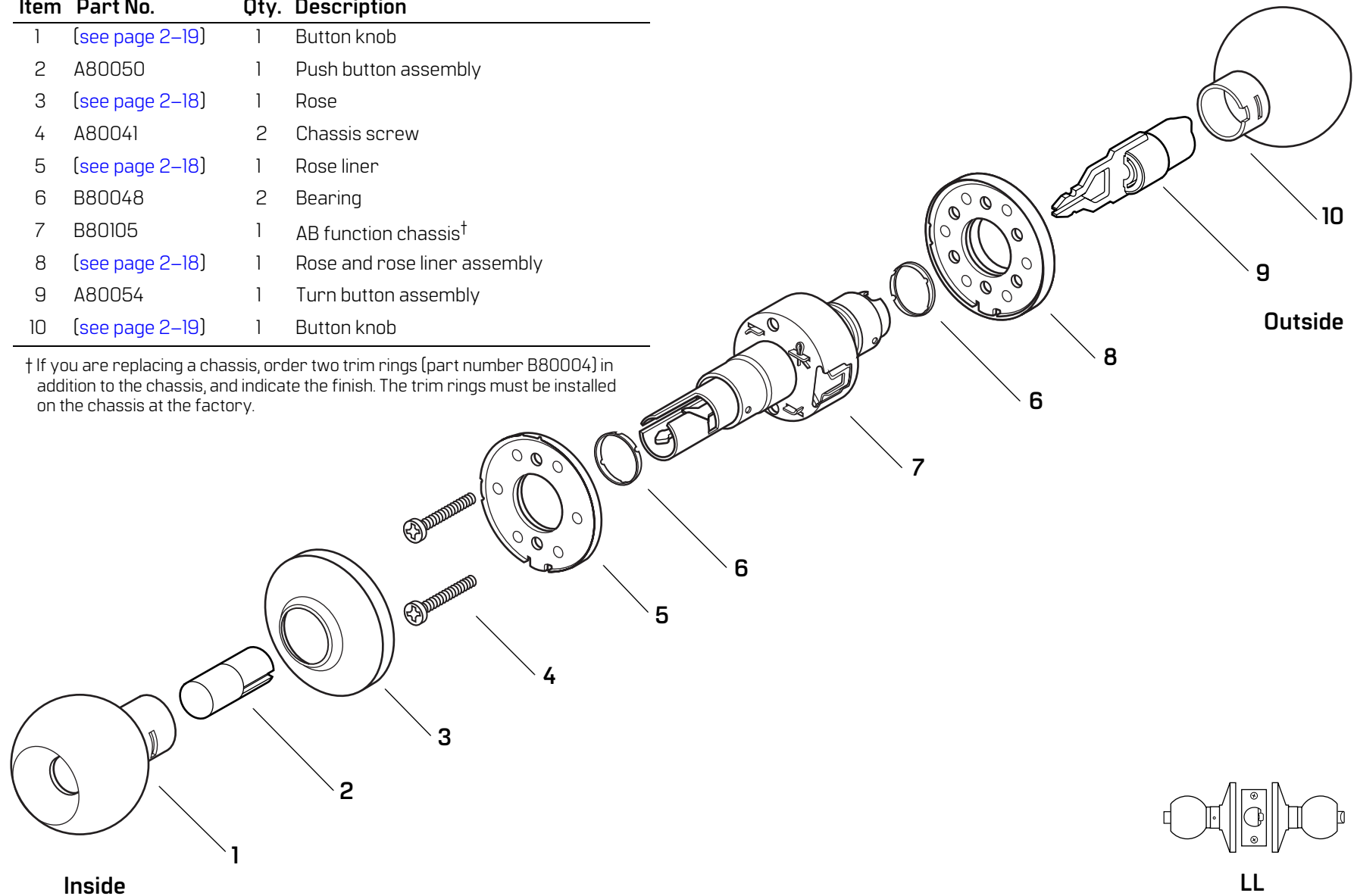

Figure 2.7 LL function exploded diagram

N FUNCTION—PASSAGE LOCK (ANSI F75)

Item	Part No.	Qty.	Description
1	[see page 2-19]	1	Plain knob
2	[see page 2-18]	1	Rose
3	A80041	2	Chassis screw
4	[see page 2-18]	1	Rose liner
5	B80048	2	Bearing
6	B80171	1	N function chassis†
7	[see page 2-18]	1	Rose and rose liner assembly
8	[see page 2-19]	1	Plain knob

† If you are replacing a chassis, order two trim rings (part number B80004) in addition to the chassis, and indicate the finish. The trim rings must be installed on the chassis at the factory.

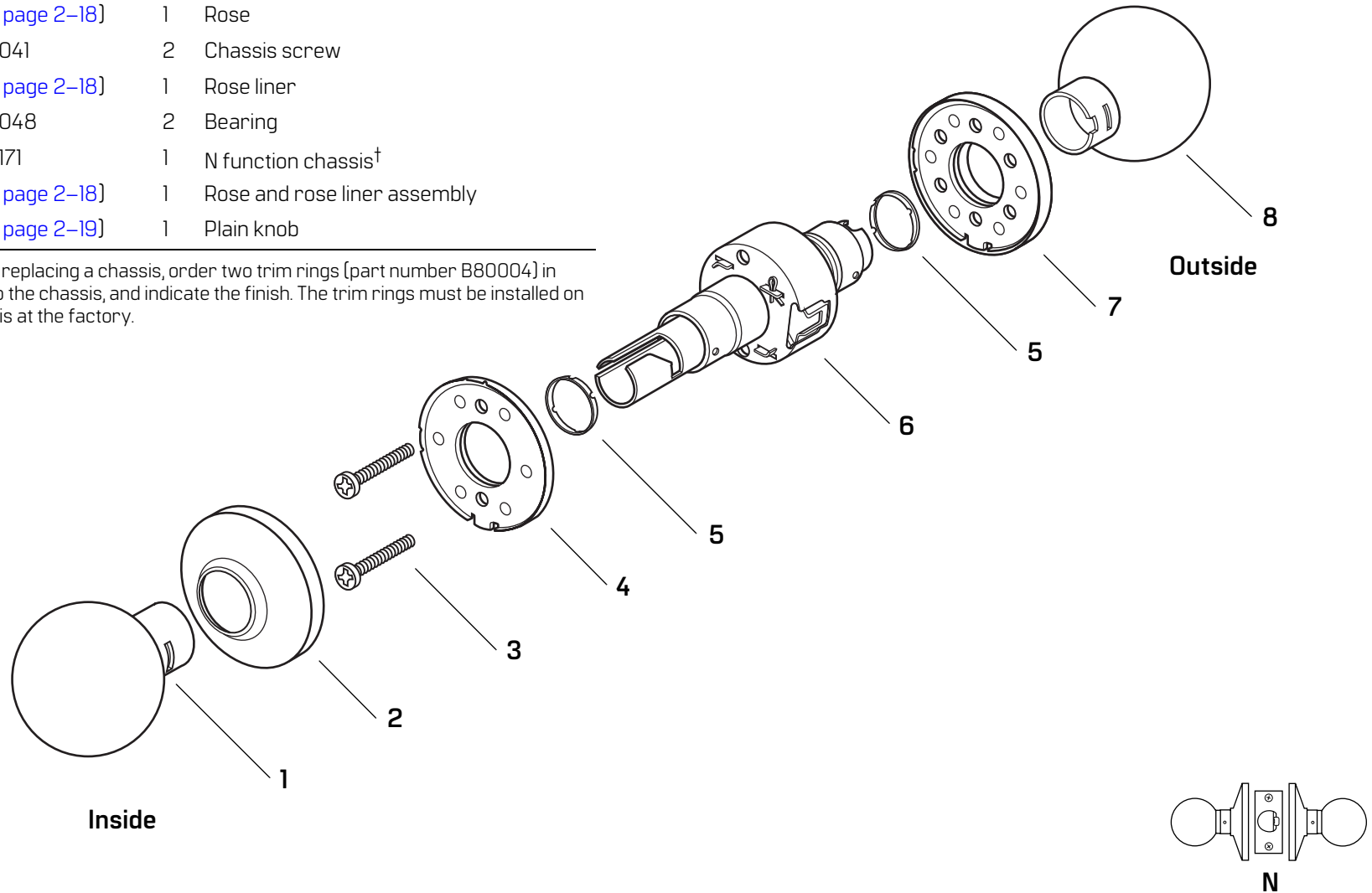

Figure 2.8 N function exploded diagram

P FUNCTION—PATIO LOCK (ANSI F77)

Item	Part No.	Qty.	Description
1	[see page 2-19]	1	Button knob
2	A80053	1	Push button assembly
3	[see page 2-18]	1	Rose
4	A80041	2	Chassis screw
5	[see page 2-18]	1	Rose liner
6	B80048	2	Bearing
7	B80105	1	AB function chassis†
8	[see page 2-18]	1	Rose and rose liner assembly
9	[see page 2-19]	1	Plain knob

† If you are replacing a chassis, order two trim rings (part number B80004) in addition to the chassis, and indicate the finish. The trim rings must be installed on the chassis at the factory.

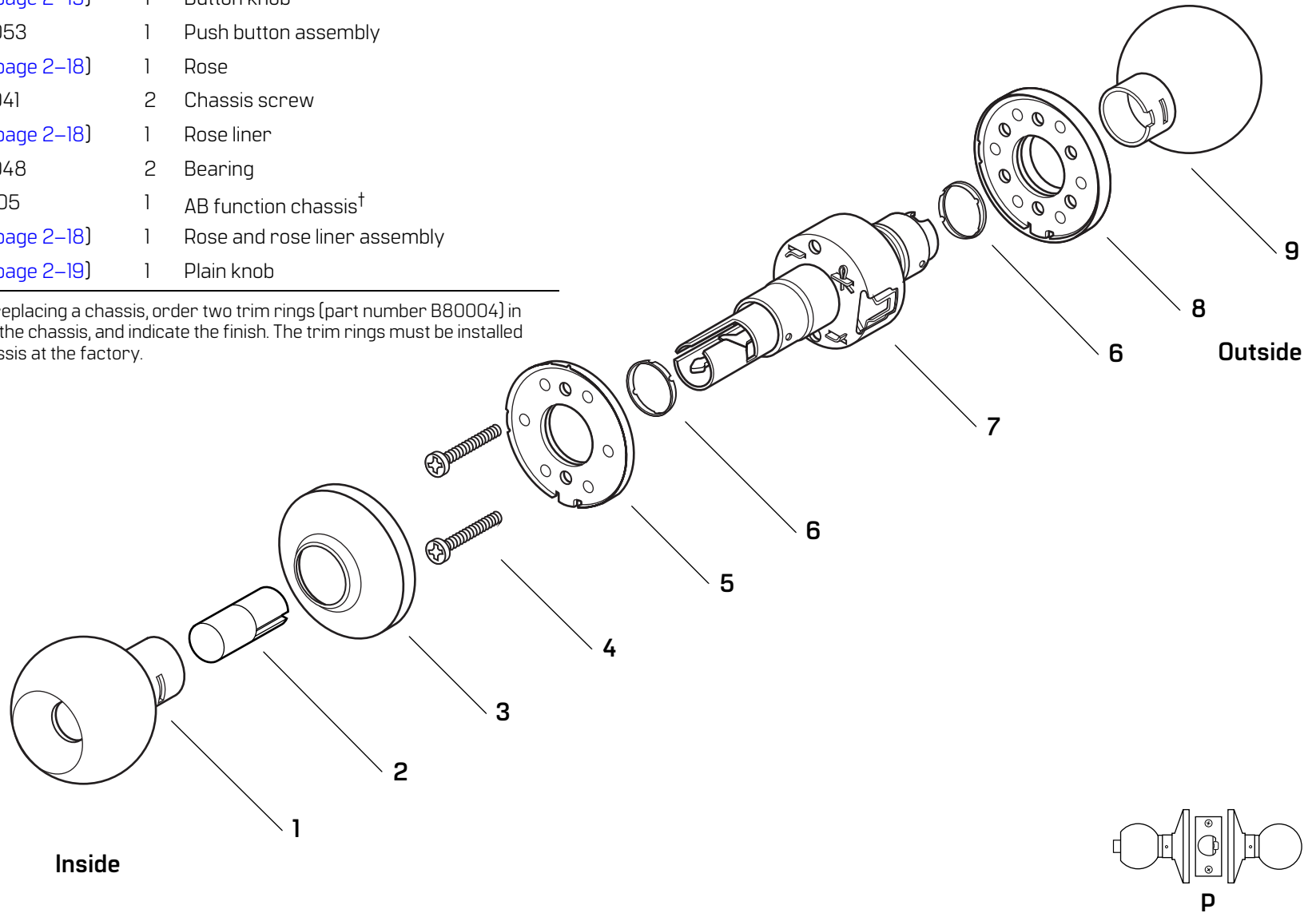

Figure 2.9 P function exploded diagram

R FUNCTION—CLASSROOM LOCK (ANSI F84)

Item	Part No.	Qty.	Description
1	[see page 2-19]	1	Plain knob
2	[see page 2-18]	1	Rose
3	A80041	2	Chassis screw
4	[see page 2-18]	1	Rose liner
5	B80048	1	Bearing
6	B80106	1	R function chassis†
7	[see page 2-18]	1	Rose and rose liner
8	[see page 2-19]	1	Keyed knob

† If you are replacing a chassis, order two trim rings (part number B80004) in addition to the chassis, and indicate the finish. The trim rings must be installed on the chassis at the factory.

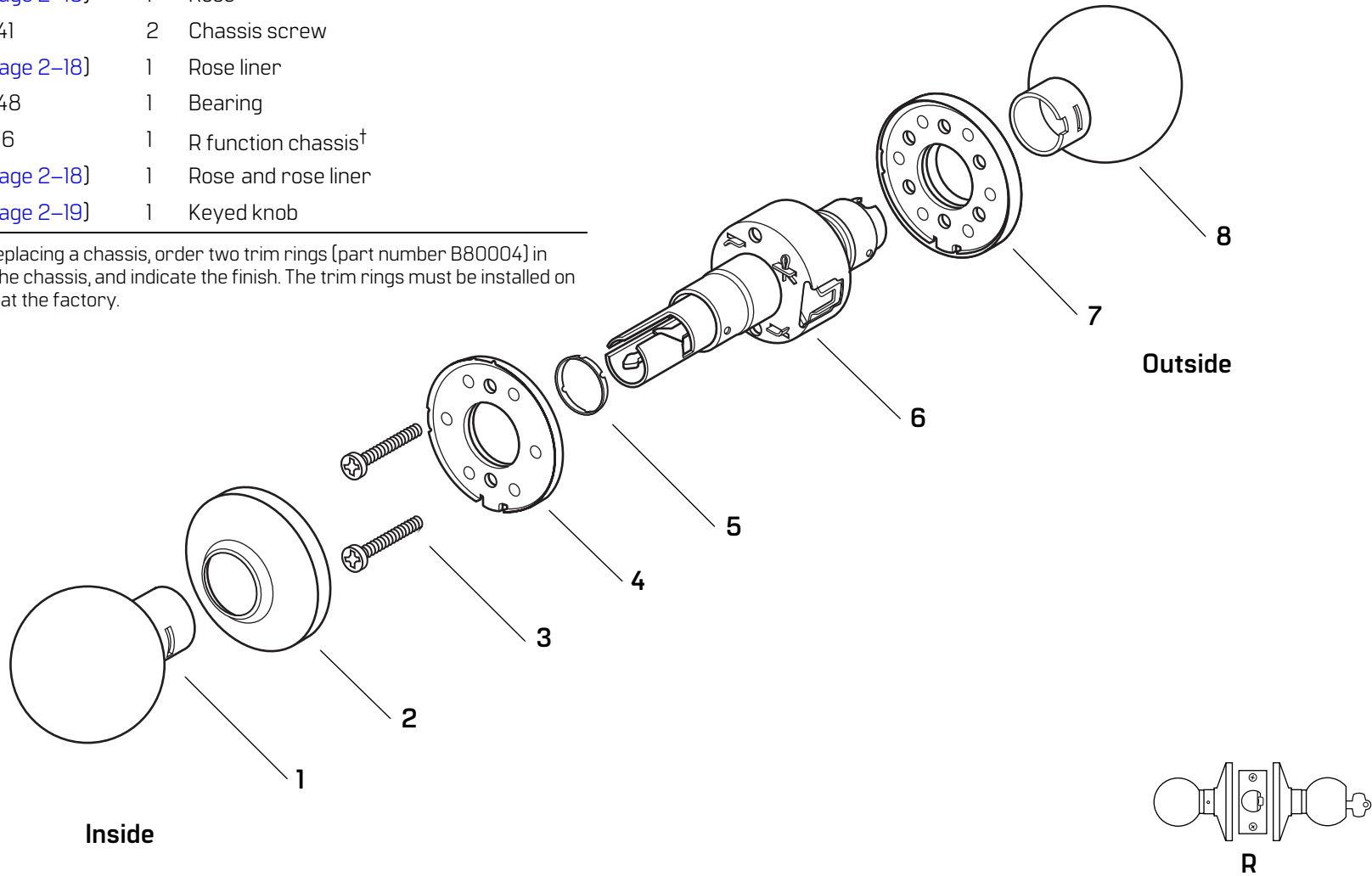

Figure 2.10 R function exploded diagram

Y FUNCTION—EXIT LOCK

Item	Part No.	Qty.	Description
1	[see page 2-19]	1	Plain knob
2	[see page 2-18]	1	Rose
3	A80041	2	Chassis screw
4	[see page 2-18]	1	Rose liner
5	B80048	1	Bearing
6	B80107	1	Y function chassis†
7	B54794	1	Y function rose assembly

† If you are replacing a chassis, order one trim ring (part number B80004) in addition to the chassis, and indicate the finish. The trim ring must be installed on the chassis at the factory.

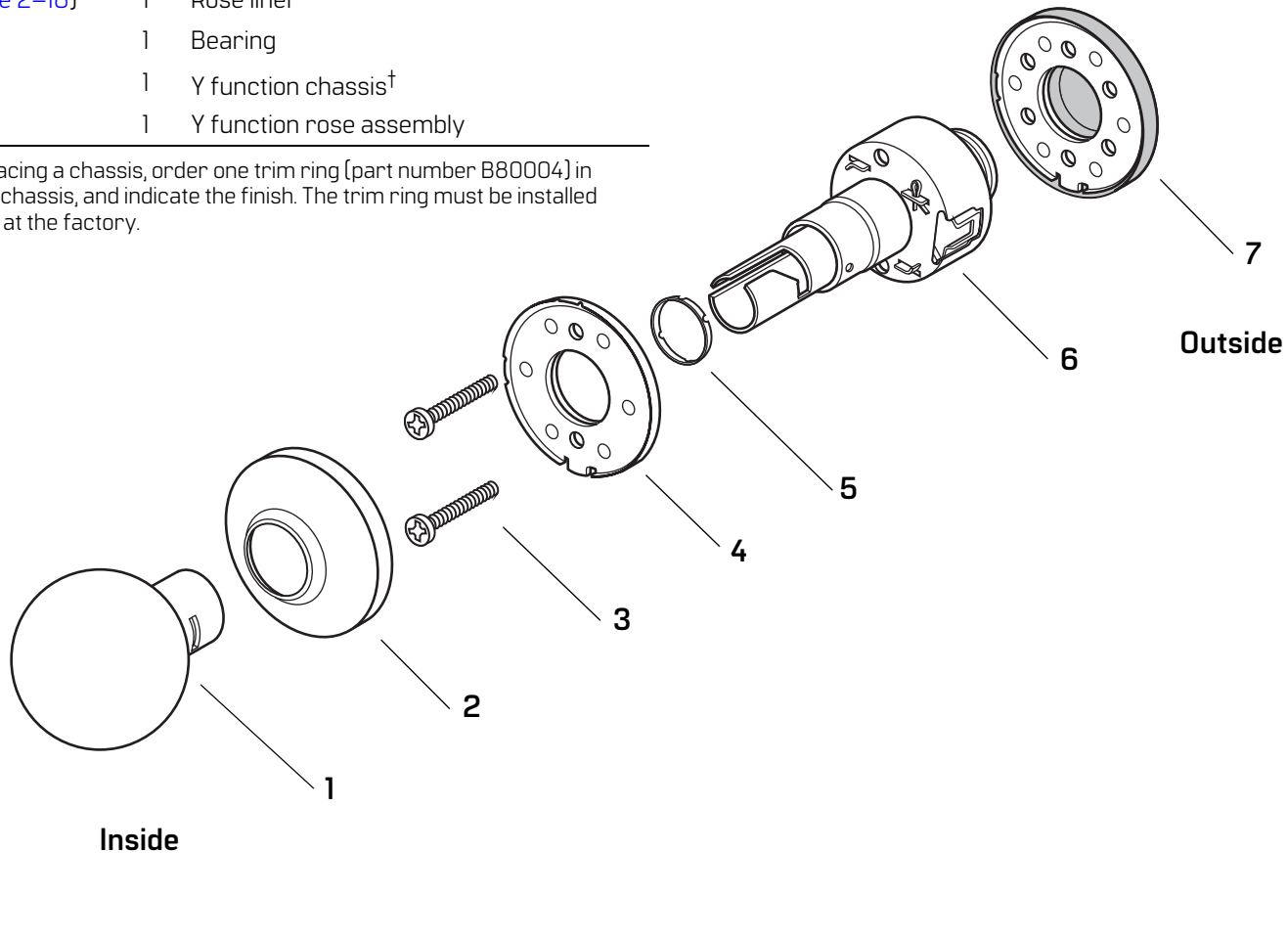

Figure 2.11 Y function exploded diagram

FUNCTION CONVERSION

If you want to convert the function of an existing AB, E, L, or LL 6K Lock, use the following table to determine the parts that you need. Unless otherwise noted, a quantity of one is used for each part.

Compare the column of the function you currently have with the column of the function you need to determine the new parts necessary for conversion. For example, to convert an AB function to an E function, you need an A80051 E button assembly—the only differing part as shown in the table below.

Note: For instructions on replacing the parts listed below, see *Replacing parts* on [page 3–2](#).

Standard functions

Part No.	Description	AB	E	L	LL
A80050	AB button assembly	■			
A80051	E button assembly		■		
A80052	L, LL inside button assembly			■	■
A80053	L outside button assembly			■	
A80054	LL outside button assembly				■
(see page 2–19)	Button knob	■	■	■†	■†
(see page 2–19)	Keyed knob	■	■		
B80004	Bearing	■	■	■†	■†
A80170	Throw member	■	■		

† Requires two.

TRIM PARTS

Strikes and strike boxes

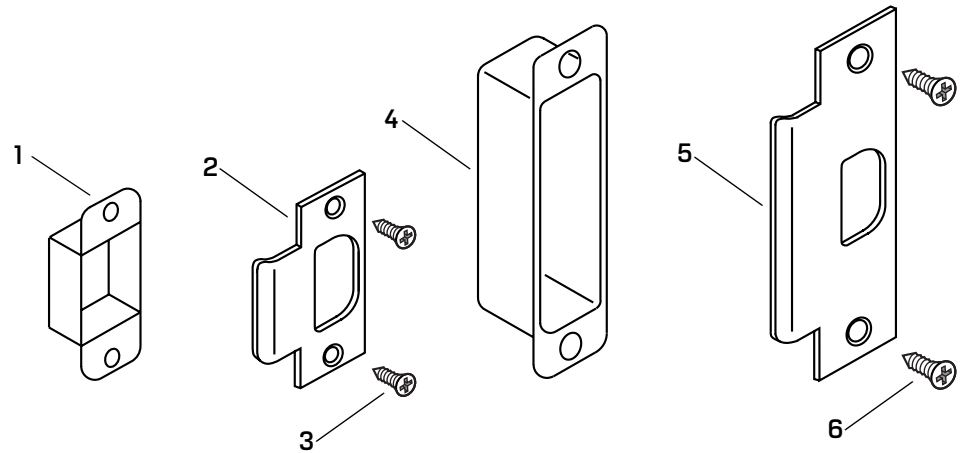

Figure 2.12 Strikes and strike boxes

Standard strikes and strike boxes parts list

Item	Nomenclature	Part No.	Description
1	8KS1	B25640	Standard steel strike box
2	6KS2†	A53761	Standard strike
3		A25359	Strike screw
4	30HS4	B34380	ANSI plastic strike box
5	6KS3‡	A53773	ANSI strike
6		A18724	Strike screw

† Includes one A53761 strike, two A25359 strike screws, and one B25640 strike box.

‡ Includes one A53773 strike and two A18724 strike screws.

Roses and
rose liners

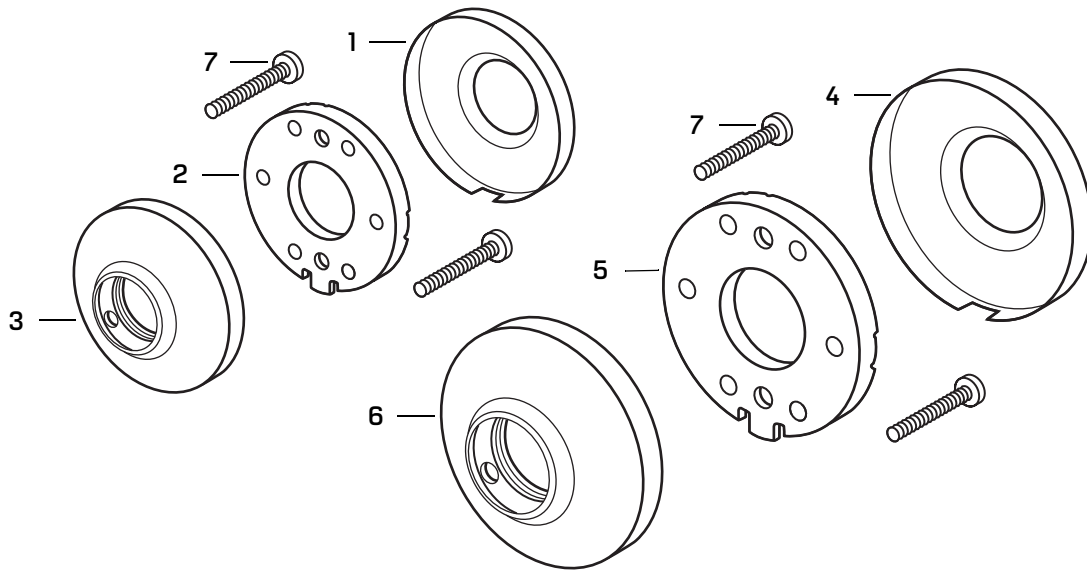

Figure 2.13 Roses and rose liners

Roses and rose liners parts list

Item	For rose	Part No.	Qty.	Description
1	C	B80010	1	Small rose
2	C	C80014	1	Small liner
3	C	B80108	1	Small outside rose and liner assembly
4	D	B80009	1	Large rose
5	D	C80013	1	Large liner
6	D	B80109	1	Large rose and liner assembly
7	C & D	A80041	2	Through-bolt screw

**Knobs and
throw member**

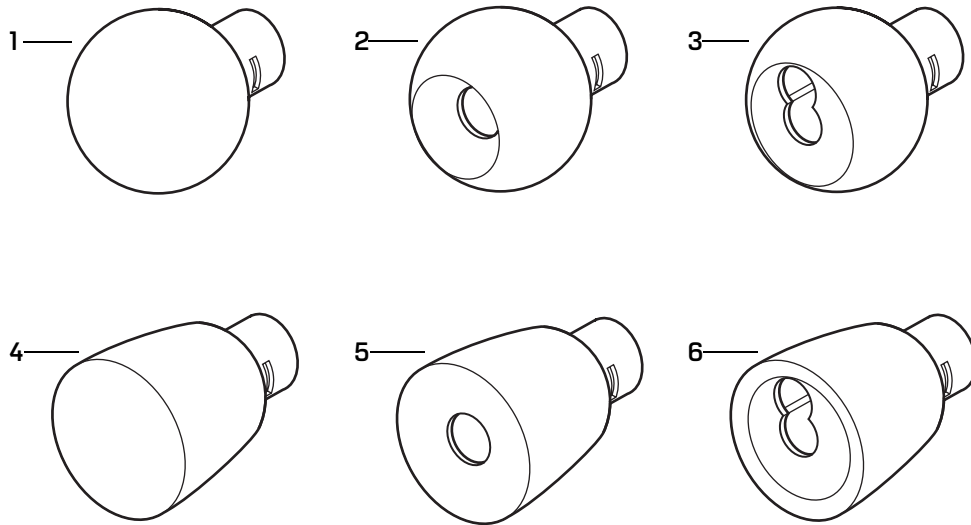

Figure 2.14 Knobs

Knobs parts list

Style	Item	Part No.	Description
	1	C80018	Plain round knob
4	2	C80017	Button round knob
	3	B80148	Keyed round knob
	4	C80020	Plain tulip knob
6	5	C80019	Button tulip knob
	6	B80151	Keyed tulip knob

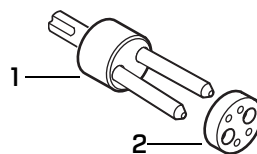

Figure 2.15 Throw member and spacer

Throw member part list

Item	Part No.	Qty.	Description
1	A80170	1	Throw member†
2	1882120	50	Spacer

† For information about cores and keys, see the *Core and Key Service Manual*.

Dummy trim

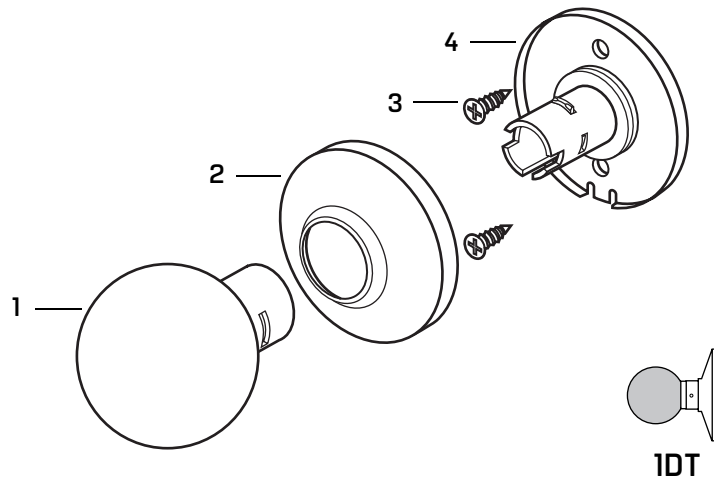

Figure 2.16 Dummy trim parts

Single dummy trim parts list

Note: If you need dummy trim for both sides of the door, order the 2DT.

Item	Part No.	Qty.	Description
1	C80018	1	Round plain knob <i>or</i>
not shown	C80020	1	Tulip plain knob
2	B80024	1	Small rose <i>or</i>
not shown	B80023	1	Large rose
3	A25359	2	Mounting screw
4	B80119	1	Small hub assembly <i>or</i>
not shown	B80118	1	Large hub assembly

Latches and latch tube sleeve

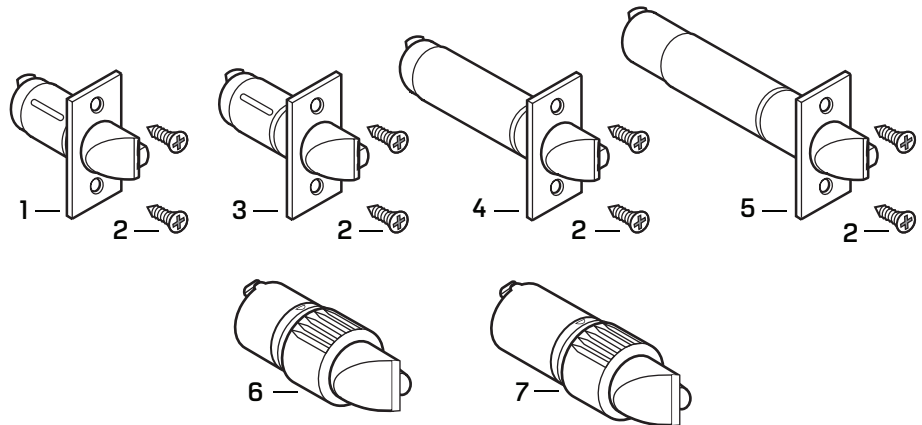

Figure 2.17 Latches

Latches parts list

Item	Part No. [†]	Nomenclature	Backset	Description
1	B80112	6KL2-NF [‡]	2 3/8"	Deadlocking latch with narrow face (1")
not shown	B80188	6KL2-WF [‡]	2 3/8"	Deadlocking latch with wide face (1 1/8")
2	A25359			Latch screw
3	B80189	6KL3-NF [‡]	2 3/4"	Deadlocking latch with narrow face (1")
not shown	B80113	6KL3-WF [‡]	2 3/4"	Deadlocking latch with wide face (1 1/8")
4	B80194	6KL4-NF [‡]	3 3/4"	Deadlocking latch with narrow face (1")
not shown	B80195	6KL4-WF [‡]	3 3/4"	Deadlocking latch with wide face (1 1/8")
5	B80196	6KL5-NF [‡]	5"	Deadlocking latch with narrow face (1")
not shown	B80197	6KL5-WF [‡]	5"	Deadlocking latch with wide face (1 1/8")
6	A80192	6KL2-L8	2 3/8"	Drive-in latch
7	A80193	6KL3-L8	2 3/4"	Drive-in latch
not shown	B80090		2 3/8"	Semi-automatic latch\
not shown	B80091		2 3/4"	Semi-automatic latch\

[†] Specify finish.

[‡] Includes the latch and two A25359 latch screws.\
Use only for B function replacements.

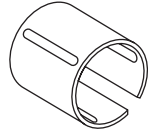

Figure 2.18 Latch Tube Sleeve

Latch tube sleeve part list

Part No.	Qty.	Description
B80044	1	Latch tube sleeve

Tools

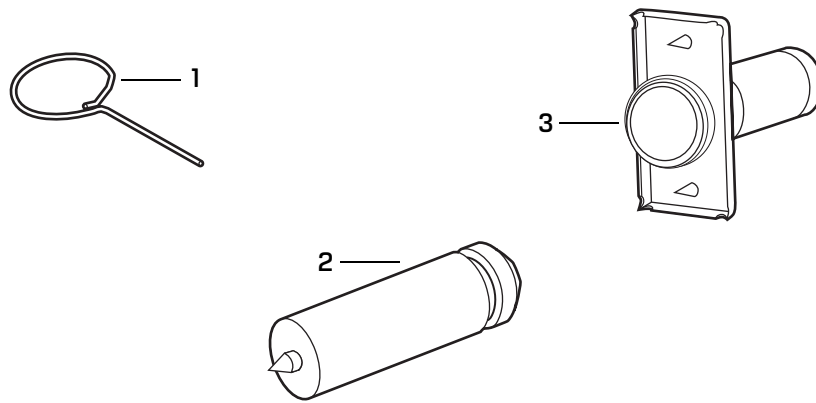

Figure 2.19 Installation tools

Installation tools part list

Item	Nomen- clature	Part No.	Description
1		A25341	Knob keeper tool
2	KD325	A01514	Strike plate locating pin
3	KD315	1350393	Faceplate marking chisel [1 1/8" x 2 1/4"]
not shown	KD312	1487975	Faceplate marking chisel [1" x 2 1/4"]

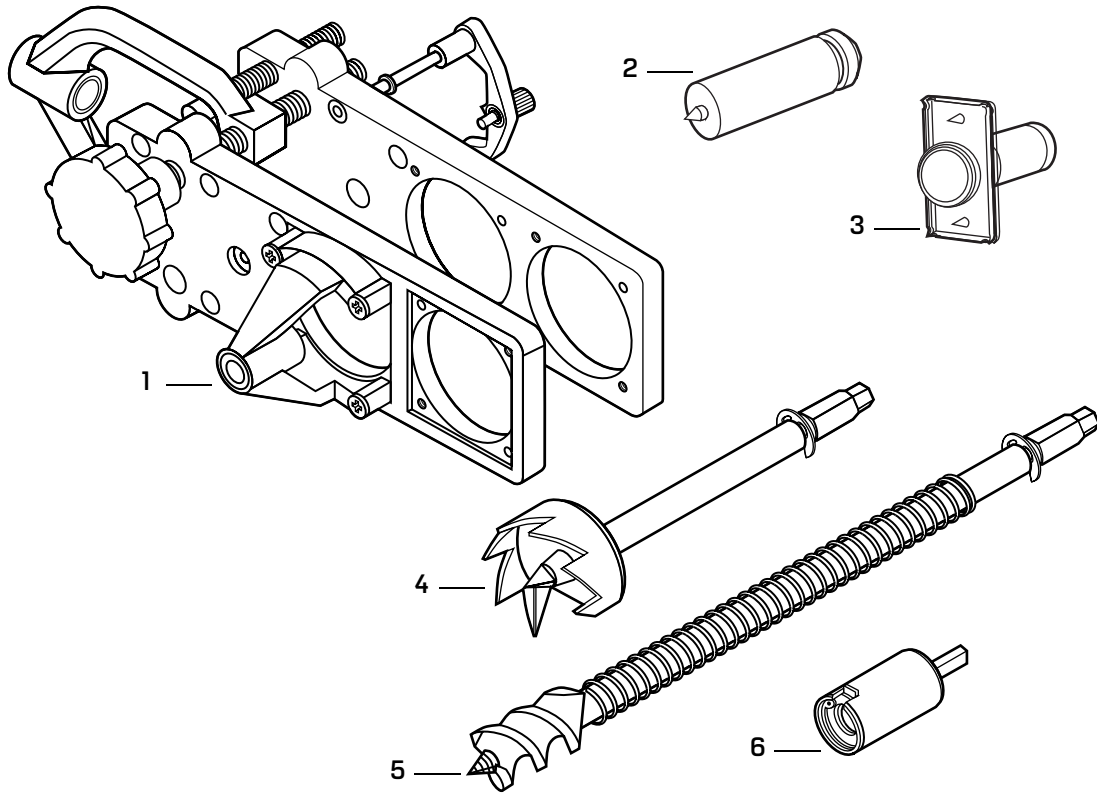

Figure 2.20 Boring jig kit

Boring jig kit parts list

Item	Nomenclature	Part no.	Description
1	N/A	N/A	Boring jig [†]
2	KD325	A01514	Strike plate locating pin
3	KD315	1350393	Faceplate marking chisel (1 1/8" × 2 1/4")
not shown	KD312	1487975	Faceplate marking chisel (1" × 2 1/4")
4	KD309	A54084	2 1/8" diameter chassis hole bit assembly
5	KD318	A54085	1" diameter drill bit assembly
6	N/A	N/A	Adaptor for 3/8" drill chuck [†]
1-6	KD304A	N/A	Boring jig kit

[†] Can only be ordered as part of the KD304A boring jig kit.

3

SERVICE AND MAINTENANCE

This chapter contains instructions for replacing components, servicing and maintaining components, and troubleshooting common problems.

To	See page
Replace knobs	3-3
Replace inside roses and rose liners	3-7
Replace outside rose and liner assemblies	3-8
Replace button assemblies	3-4
Lubricate cores	3-10
Align chassis and trim	3-11
Troubleshoot common problems	3-12

REPLACING PARTS

Replacing the core and throw member

To remove the core and throw member:

1. Insert the control key into the core and rotate the key 15 degrees to the right.
2. Remove the core and throw member from the knob.

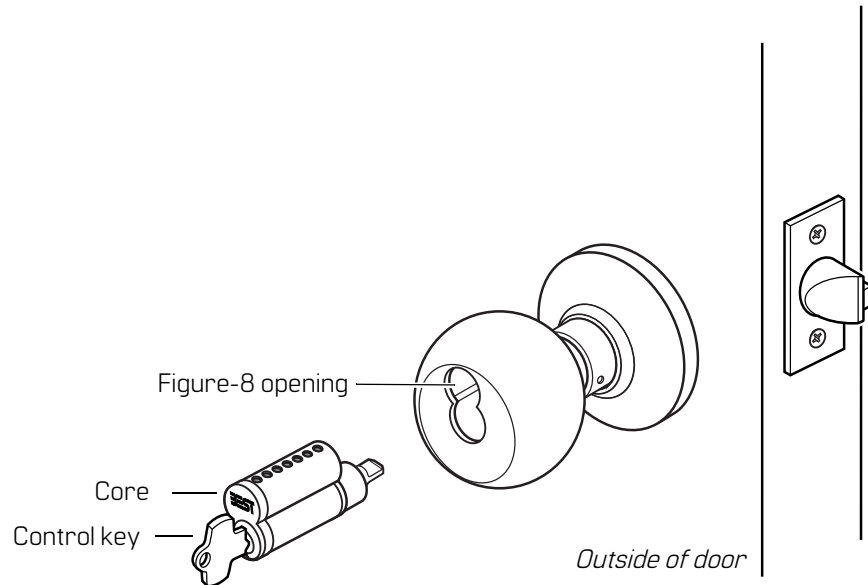

Figure 3.1 Removing and reinstalling the core

To reinstall the core and throw member:

1. *For R function locks*, insert a screwdriver into the figure-8 opening and turn the locking mechanism counterclockwise as far as it will go.
For all other function locks, go to step 2.
2. Insert the control key into the core and rotate the key 15 degrees to the right.
3. Using the control key, insert the core and throw member into the knob. Rotate the control key 15 degrees to the left and remove the key.

Replacing the knob **To remove the knob:**

1. *For keyed knobs*, remove the core and throw member ([page 3–2](#)).
For all other knobs, go to step 2.
2. Insert the knob keeper tool into the hole on the trim ring, as shown in [Figure 3.2](#). Slide the knob off of the sleeve.

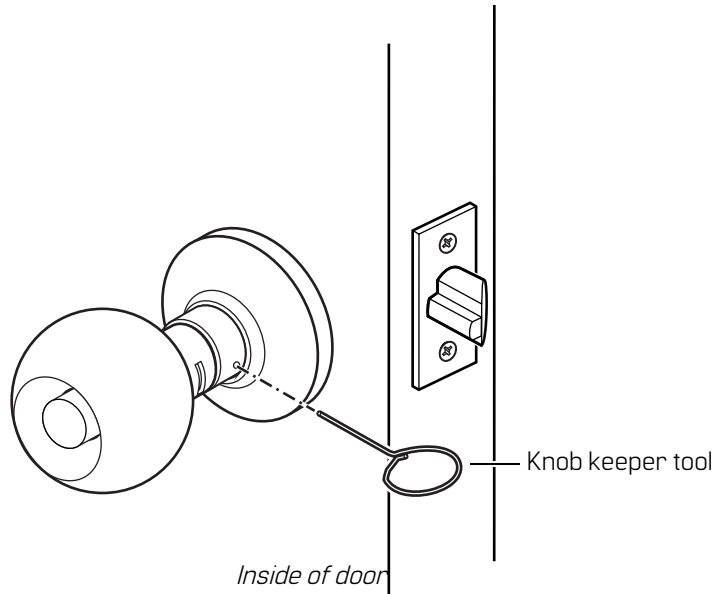

Figure 3.2 Removing the knob

To reinstall the non-keyed knob:

1. Align the two lugs (dimples) in the knob with the long slot in the sleeve, as shown in [Figure 3.3](#).
2. Slide the knob onto the sleeve and firmly push on the knob until it is seated.
3. Turn the knobs to check that they operate smoothly.

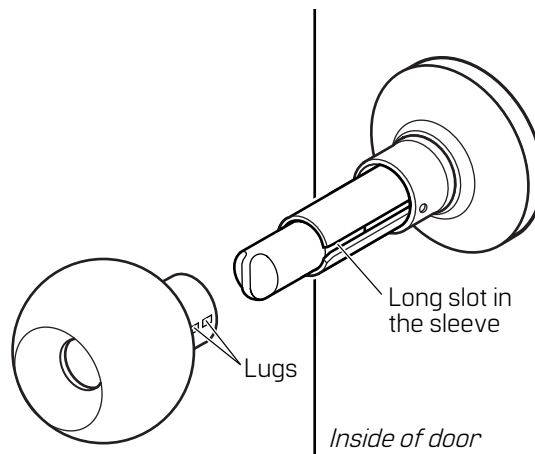

Figure 3.3 Reinstalling the non-keyed knob

To reinstall the keyed knob:

1. Align the two drive lugs on the inside of the knob with the short slots in the sleeve.
2. Insert the knob keeper tool into the hole on the trim ring and slide the knob onto the sleeve. Firmly push on the knob until it is seated.
3. Reinstall the core and throw member (page 3-2).

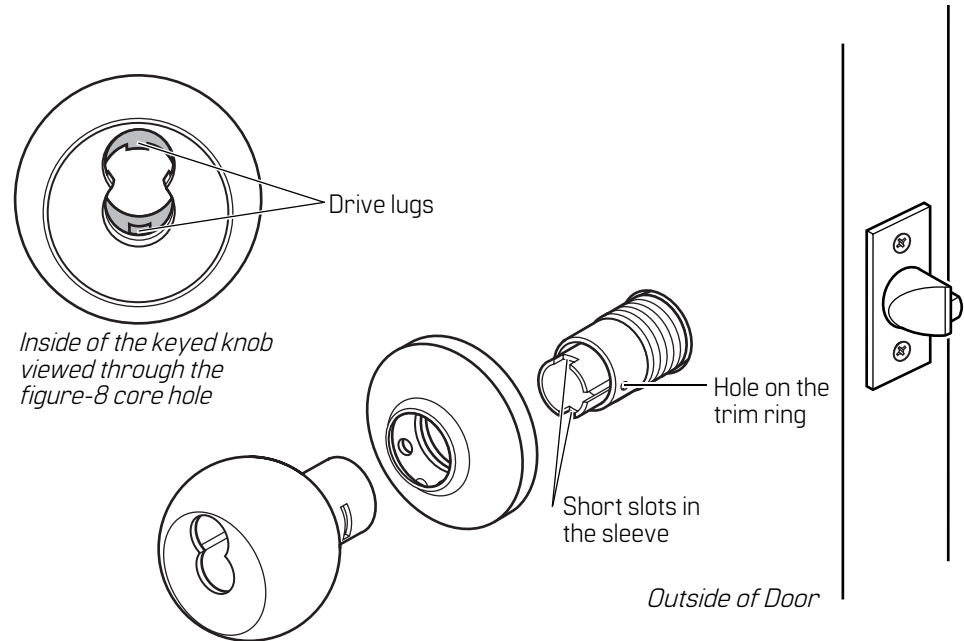

Figure 3.4 Reinstalling the keyed knob

Replacing the button assembly

To remove the button assembly:

Note: These instructions apply to all types of button assemblies.

1. Remove the knob (page 3-3).
2. Insert a flat blade screwdriver behind the plastic button retainer and pry the button assembly from the locking bar.

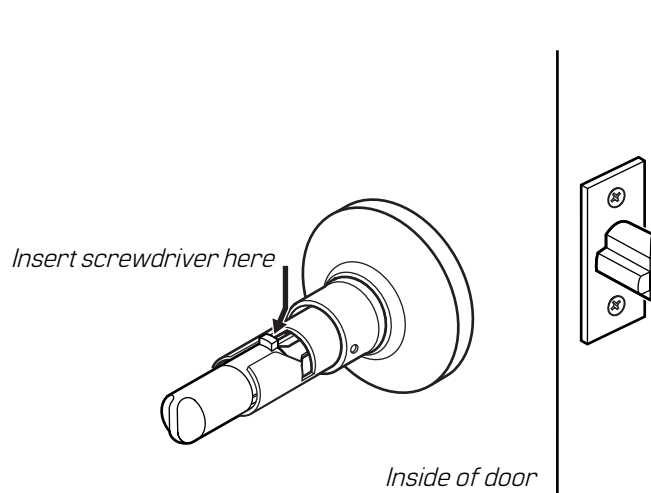

Figure 3.5 Removing the button assembly

To reinstall the outside button assembly:

1. Position the button assembly so that the button slot is horizontal.
2. Insert the button assembly into the cross slot on the inside of the sleeve. Firmly press the button assembly into place.

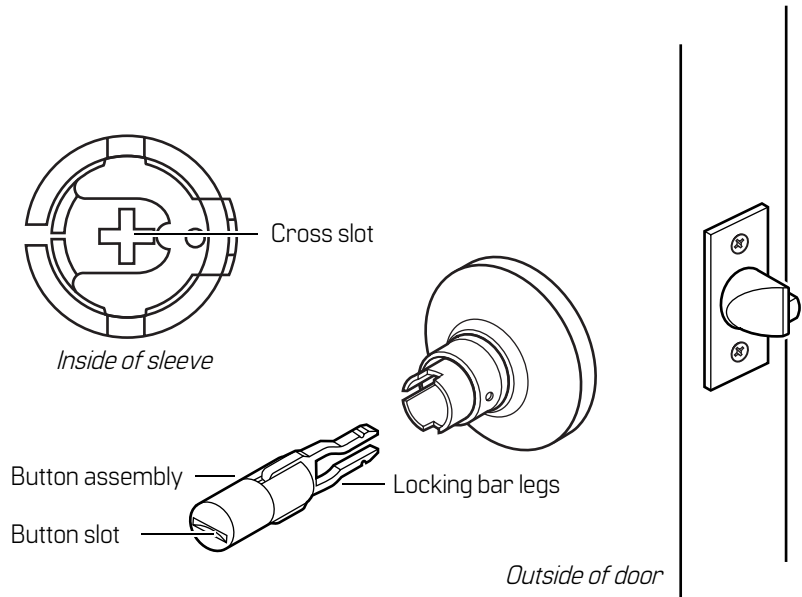

Figure 3.6 Reinstalling the outside button assembly

To reinstall the inside button assembly:

1. *For turn buttons*, align the button tab with the sleeve's top slot. *For push buttons*, go to step 2.
2. Firmly press the button assembly onto the locking bar until it is seated.
3. Reinstall the knob [page 3–3].

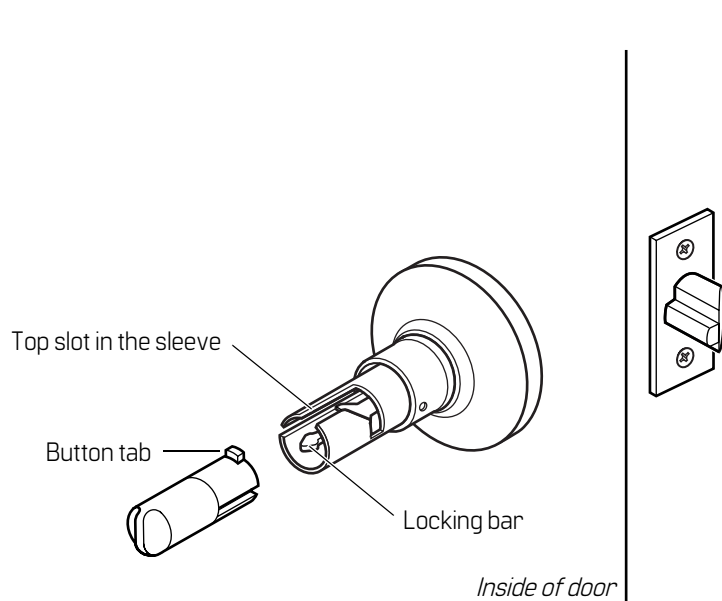

Figure 3.7 Reinstalling the inside button assembly

Replacing the bearing

To remove the bearing:

1. Remove the knob [page 3-3].
2. Remove the bearing from underneath the trim ring. Slide the bearing off of the sleeve.

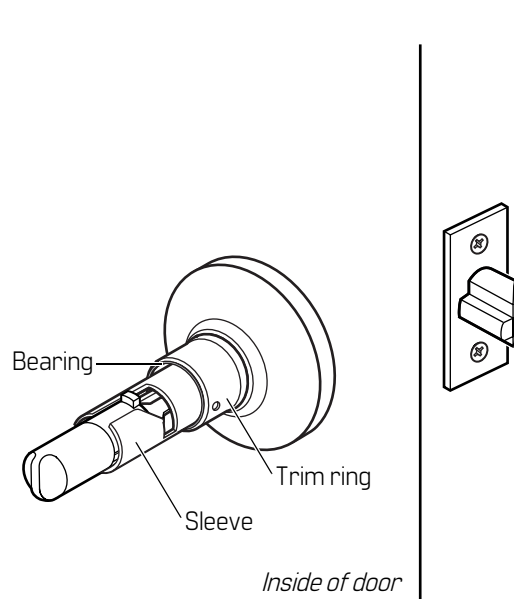

Figure 3.8 Removing the bearing

To reinstall the bearing:

1. Position the bearing so that the cutouts face the trim ring. Slide the bearing onto the sleeve and snap it into place underneath the trim ring.
2. Reinstall the knob [page 3-3].

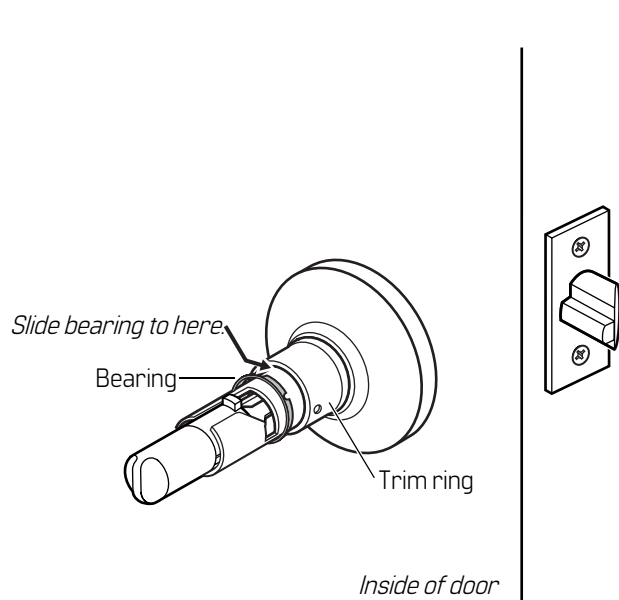

Figure 3.9 Reinstalling the bearing

Replacing the inside rose and rose liner

To remove the inside rose and rose liner:

1. Remove the inside knob ([page 3-3](#)).
2. Insert a flat blade screwdriver at the slot in the rose and pry the rose from the rose liner. Slide the rose off of the sleeve.
3. Unscrew the two through-bolts. Save the through-bolts.
4. Slide the rose liner off of the sleeve.

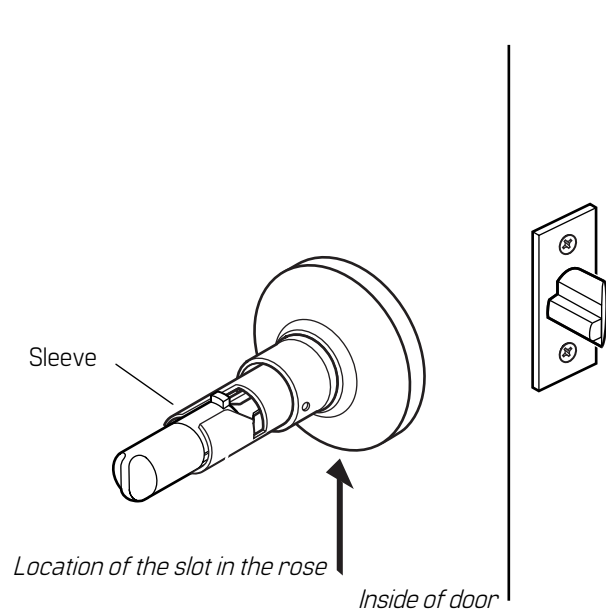

Figure 3.10 Removing the inside rose and rose liner

To reinstall the inside rose and rose liner:

1. Position the rose liner on the door so that the tab is at the bottom.
2. Install the two through-bolts through the rose liner and door in the top and bottom holes.
3. Tighten the rose liner onto the door with the through-bolts.
4. Align the slot in the rose with the tab on the rose liner and firmly press the rose until it is flush with the door.

5. Reinstall the knob [page 3–3].

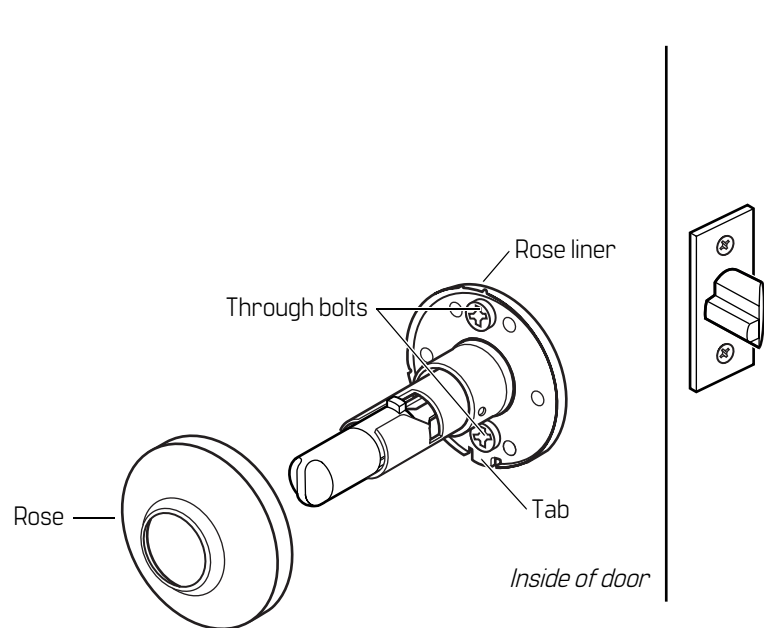

Figure 3.11 Reinstalling the inside rose and rose liner

Replacing the outside rose and liner assembly

To remove the outside rose and liner assembly:

1. Remove the outside knob [page 3–3].
2. Rotate the rose and liner assembly counterclockwise until it is free from the threading on the sleeve.
3. Remove the rose and liner assembly from the sleeve.

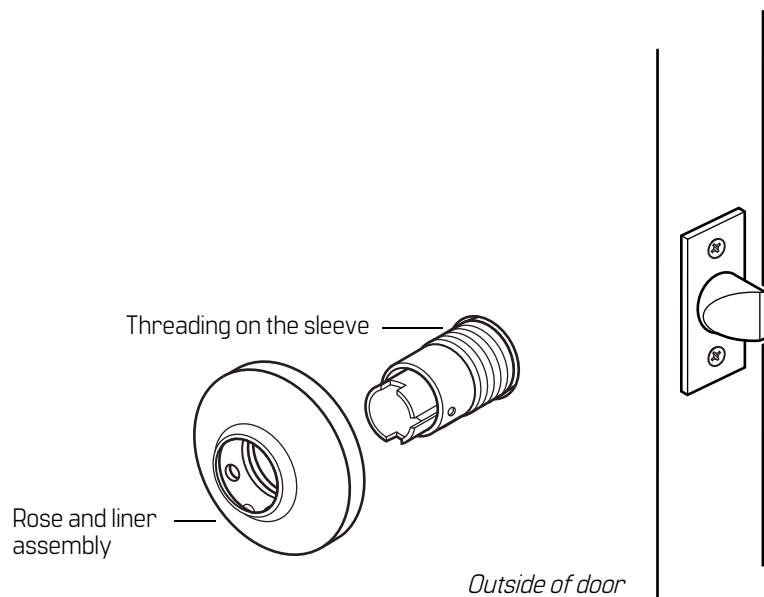
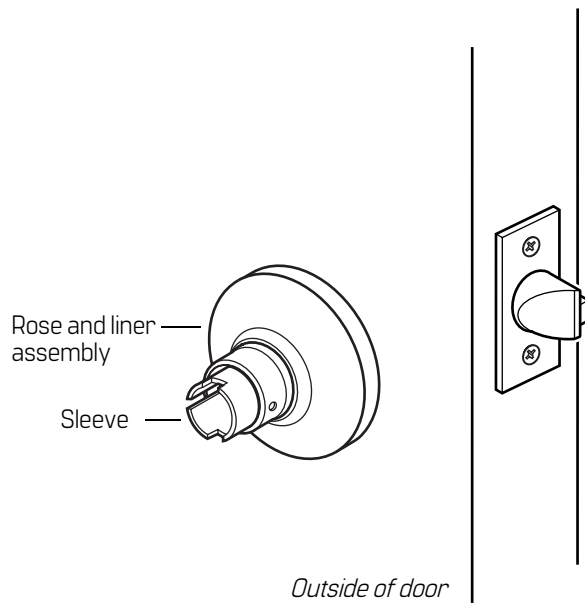

Figure 3.12 Removing the outside rose and liner assembly

To reinstall the outside rose and liner assembly:

1. Slide the rose and liner assembly onto the sleeve and rotate the rose and liner assembly clockwise until it is flush with the door.

**Figure 3.13** Reinstalling the outside rose and liner assembly

2. Reinstall the knob ([page 3-3](#)).

Replacing the lock chassis assembly**To remove the lock chassis assembly:**

1. Remove the following components:
 - knobs ([page 3-3](#))
 - inside rose and rose liner ([page 3-7](#))
 - outside rose and liner assembly ([page 3-8](#)).
2. From the outside of the door, slide the lock chassis out of the door.

To reinstall the lock chassis assembly:

1. From the outside of the door, install the lock chassis. Make sure that the latch tabs engage the chassis frame and the latch tailpiece engages the retractor.

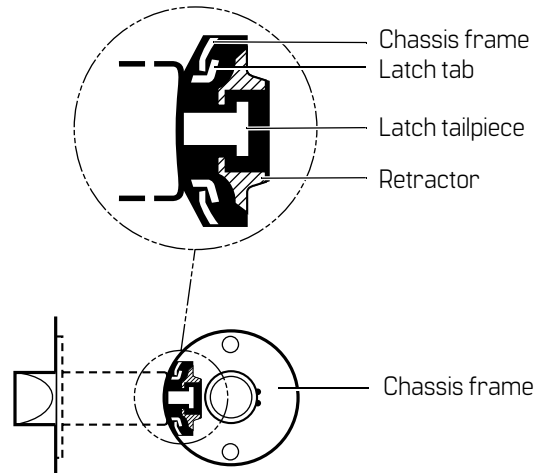

Figure 3.14 Engaging the retractor in the latch

2. Reinstall the following components:
 - outside rose and liner assembly [page 3–9]
 - inside rose and liner assembly [page 3–7]
 - knobs [page 3–3].

LUBRICATING THE CORE

Create a preventive maintenance plan that includes lubricating the core. To extend the life of the core, lubricate it regularly. Powdered graphite is the best choice for lubrication; LPS spray can also be used.



Do not lubricate a core with oil. Doing so will attract dirt.

For powdered graphite lubrication:

1. Remove the core from the lock [page 3–2].
2. Dip a key in graphite. With the core inverted, insert the key into the keyhole and remove it; repeat several times, allowing the graphite to penetrate the barrels. *OR*

With the core inverted, spray graphite into the keyhole. Insert the key into the keyhole and remove it; repeat several times, allowing the graphite to penetrate the barrels.

For LPS lubrication:

1. Remove the core from the lock ([page 3-2](#)).
2. Spray compressed air or LPS lubricant into the core to clean out all of the existing lubricant.
3. With the core inverted, spray the lubricant into the key opening, allowing the spray to penetrate the barrels.

**Caution**

Do not mix graphite with LPS lubricant.

ALIGNING THE CHASSIS AND TRIM

Establish a schedule to inspect locks, doors, and door hardware for proper alignment and operation. Occasionally a lock chassis and/or rose trim may become loose and require tightening.

To retighten a loose or misaligned chassis or rose trim:

1. Remove the following components:
 - inside knob ([page 3-3](#))
 - inside rose and rose liner ([page 3-7](#)).
2. Align the chassis with the latch. Make sure that the latch tabs engage the chassis frame and the latch tailpiece engages the retractor, as shown in [Figure 3.15](#).

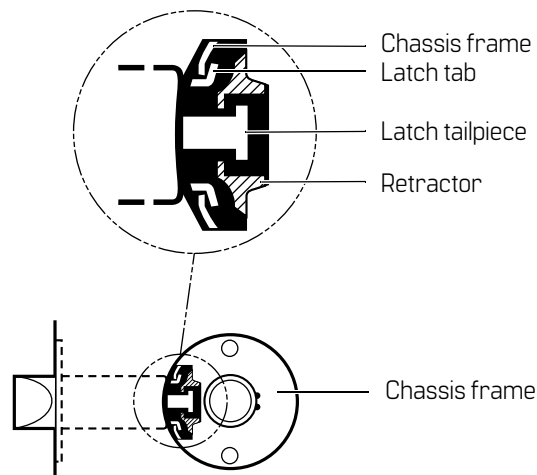

Figure 3.15 Engaging the retractor in the latch

3. Tighten the through-bolts.
4. Test the knob operation to make sure that the latch tailpiece does not bind with the chassis retractor.
5. Reinstall the following components:
 - inside rose and rose liner ([page 3-7](#))
 - inside knob ([page 3-3](#)).

TROUBLESHOOTING

This table summarizes the possible causes for certain lock problems. The causes are listed in the order of likelihood. (The most likely cause is first, and so forth.)

You notice...	Possible causes include...	You should...
Knob won't return to its normal position.	<ul style="list-style-type: none">a. There is binding between the knob and rose.b. Knob bearing is damaged.	<ul style="list-style-type: none">a. Ensure that the lock chassis is centered within the door (page 3-11).b. Replace the knob bearing (page 3-6).
Key spins freely, but won't retract the latch or unlock the door.	<ul style="list-style-type: none">a. Throw member is not installed.b. 6-pin core is installed with a 7-pin throw member.	<ul style="list-style-type: none">a. Install the throw member.b. Change the core or throw member (page 3-2).
Core doesn't fit into the knob core hole.	<ul style="list-style-type: none">a. 7-pin core is installed with a 6-pin throw member.b. Keyed knob is defective.	<ul style="list-style-type: none">a. Change the core or throw member (page 3-2).b. Replace the keyed knob (page 3-3).
Button doesn't pop out as expected.	Button retainer or locking bar legs are damaged.	Replace the button assembly (page 3-4).
Latch doesn't retract.	<ul style="list-style-type: none">a. Latch tailpiece is broken.b. Latch tailpiece didn't engage the retractor correctly during installation.	<ul style="list-style-type: none">a. Replace the latch assembly.b. Reinstall the lock chassis (page 3-10).

A

INSTALLATION INSTRUCTIONS

The following pages contain the *Installation Instructions for 6K Cylindrical Locks*.

Installation Instructions for 62K–65K Cylindrical Locks

For factory prepared doors only

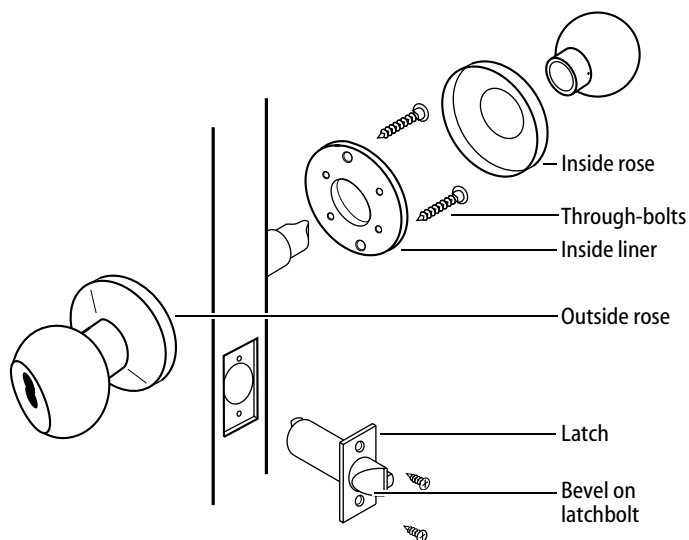

Figure 1 — Overview diagram

Caution: If you use hollow metal doors, determine whether the doors are reinforced enough to support the lock. If door reinforcement is not adequate, consult the door manufacturer for information on proper reinforcement.

Simplified instructions

- 1 Install the latch so that the bevel on the latchbolt faces the strike.
- 2 Adjust the outside rose assembly so that the chassis is centered in the door. Install the chassis from the outside of the door.
- 3 Install the inside liner, through-bolts, rose, lever, and strike.

For field door preparation and detailed installation instructions, see the following steps.

1 Position template

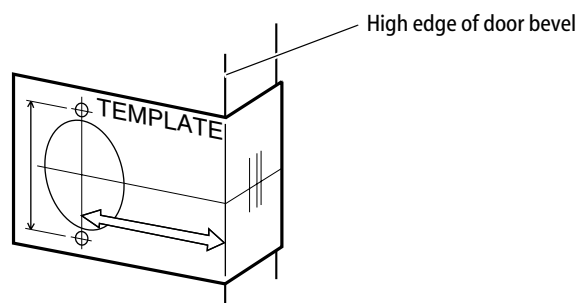

Figure 2 — Positioning the template

- 1 Fold the template and place in position on the high edge of the door bevel (see Figure 2).
- 2 Mark the drill points for lock and latch.

Note: The suggested height from floor to centerline of the lock is 40 5/16". If steel frames are used, the latch centerline must be in line with the center of the strike preparation.

2 Bore two holes and install latch

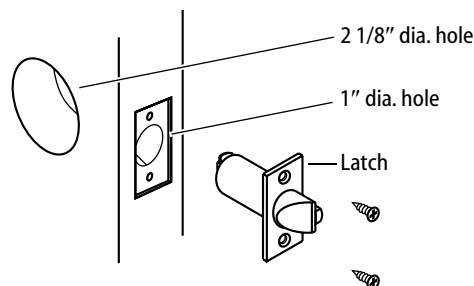

Figure 3 — Boring two holes and installing the latch

- 1 Bore a 2 1/8" diameter hole from both sides of the door, to the center of the door as shown in Figure 3.
- 2 Drill a 1" diameter hole from the edge of the door that intersects the 2 1/8" hole.
- 3 Mortise the door edge for the latch face.
- 4 Install the latch and check the door swing. Latch tabs should project into the 2 1/8" diameter hole.

3 Remove inside knob and rose & liner assembly

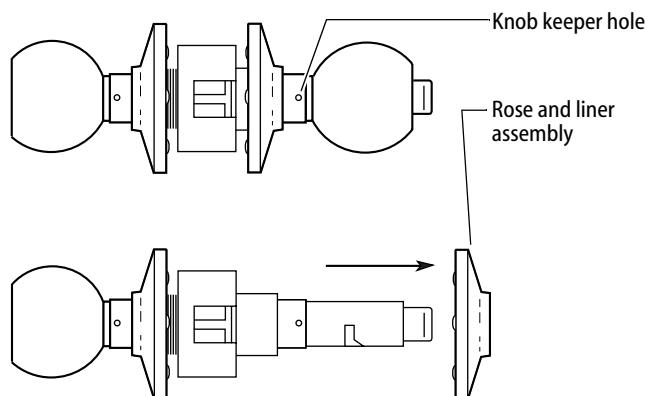

Figure 4 — Removing the inside knob and rose & liner assembly

- 1 Insert the spanner wrench tip into the knob keeper hole and depress the keeper.
- 2 Slide the knob off.
- 3 Remove the rose and liner assembly.

4 Adjust to door thickness

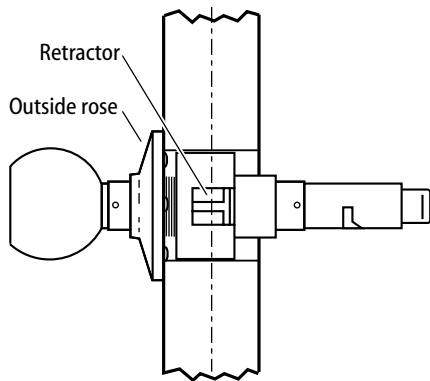

Figure 5 — Centering the retractor

- Rotate the outside rose in or out until the retractor is centered in the door.

5 Engage retractor in latch

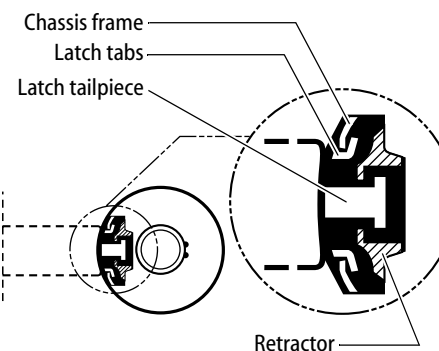

Figure 6 — Engaging the latch and retractor

- 1 With the latch in place, install the chassis from outside of the door.
- 2 Make sure that the latch tabs fit into the chassis frame and the latch tailpiece fits into the retractor.

6 Install liner and rose

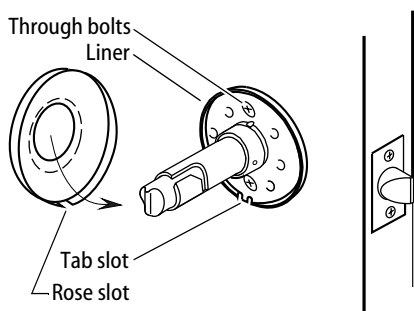

Figure 7 — Installing the rose over the liner

- 1 Separate the rose and liner (gently pry apart at the tab slot).

- 2 Place the liner in position with the tab slot at the bottom and tighten the through bolts.
- 3 Align the rose slot with the liner tab slot at the bottom and press the rose firmly onto the liner until flush with the door.

7 Install inside knob

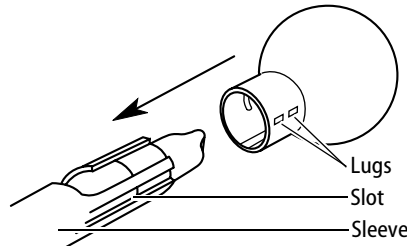

Figure 8 — Aligning and installing the inside knob

- 1 Align the two lugs (“dimples”) on the knob shank with the long slot in the sleeve and slide the knob onto the sleeve.
- 2 Make sure that the knob keeper snaps into place.
- 3 Test both knobs for functionality.

8 Install strike plate

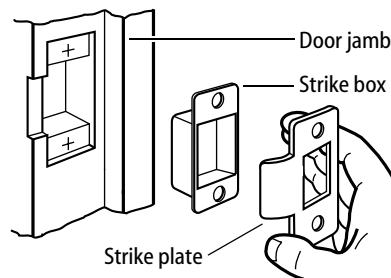

Figure 9 — Installing the strike box and plate

- 1 Mortise the door jamb to fit the strike box and strike plate. Make sure to align the strike plate and latchbolt centers.

Caution: The deadlocking plunger of the latchbolt must not enter the strike plate opening. The plunger deadlocks the latchbolt and prevents forcing the latch when the door is closed. A gap of more than 1/8" may reduce security and/or cause improper operation of the latchbolt.

- 2 Insert the strike box and secure the strike plate with the screws provided.

9 Check handing

Note: When BEST 6K locks are properly installed, the figure-8 hole must be in the

upper half of the knob. If it is not, change the hand of the lock.

To change the hand of the lock

- 1 Remove the core and throw member (if already installed). See Figure 11.

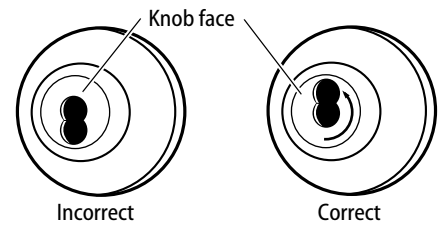

Figure 10 — Turning the knob face to correct the handing of the lock

- 2 Rotate the knob face one-half turn so that the figure-8 is in the upper half of the knob.

10 Install core

For 'R' function locks only

- Simulating the throw member, insert a screwdriver into the figure-8 opening and turn the locking mechanism counterclockwise as far as it will go before installing the core.

For all functions (including 'R' function)

For 6-pin core users only: Slide the spacer — supplied with your 6-pin cores — over the 7-pin throw member.

Note: If you have ordered 6-pin cores, you will get one spacer per core with your order. Spacers are not supplied with locks.

- 1 Insert the throw member (or throw member and spacer) into the back of the core.
- 2 Insert the control key into the core and turn the key 15 degrees clockwise.
- 3 Insert the core and throw member into the knob with the control key as shown in Figure 11.

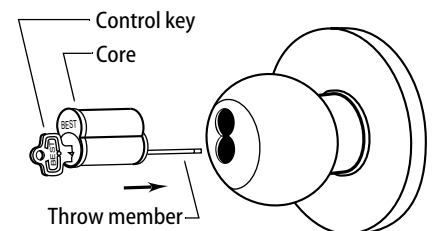

Figure 11 — Installing the core

- 4 Turn the key 15 degrees counterclockwise and remove the key.

B

INDEX

A

- AB chassis and trim
 - function conversion for [2-16](#)
 - function description for [2-2](#)
 - part numbers and drawings for [2-6](#)
- AB chassis assembly [2-6](#) to [2-7](#), [2-9](#) to [2-11](#), [2-13](#)
- aligning the chassis and trim [3-11](#)

B

- B chassis and trim
 - function description for [2-5](#)
 - part numbers and drawings for [2-7](#)
- bearing [2-6](#) to [2-15](#)
 - reinstalling [3-6](#)
 - removing [3-6](#)
- boring jig kit [2-22](#) to [2-23](#)
- button assembly
 - push button assembly [2-7](#), [2-10](#), [2-13](#)
 - reinstalling the inside assembly [3-5](#)
 - reinstalling the outside assembly [3-5](#)
 - removing [3-4](#)
 - slotted button assembly [2-9](#) to [2-10](#)
 - turn button assembly [2-6](#), [2-11](#)

C

- certifications and standards [1-1](#)
- chassis screws [2-6](#) to [2-8](#), [2-10](#) to [2-15](#)
- cores
 - lubricating [3-10](#)
 - reinstalling [3-2](#)
 - removing from a knob [3-2](#)

D

- D chassis and trim
 - function description for [2-2](#)
 - part numbers and drawings for [2-8](#)
- D chassis assembly [2-8](#)
- diagrams, exploded
 - see* part numbers and drawings
- documentation package [1-1](#)
- drawings of parts
 - see* part numbers and drawings

E

- E chassis and trim
 - function conversion for [2-16](#)
 - function description for [2-3](#)
 - part numbers and drawings for [2-9](#)
- exploded diagrams
 - see* part numbers and drawings

F

- faceplate marking chisel [2-22](#) to [2-23](#)
- function conversion [2-16](#)
- function description
 - for AB chassis and trim [2-2](#)
 - for B chassis and trim [2-5](#)
 - for D chassis and trim [2-2](#)
 - for E chassis and trim [2-3](#)
 - for L chassis and trim [2-4](#)
 - for LL chassis and trim [2-5](#)
 - for N chassis and trim [2-4](#)
 - for P chassis and trim [2-4](#)
 - for R chassis and trim [2-3](#)
 - for Y chassis and trim [2-4](#)

K

knob keeper tool 2-22
knobs 2-19

L

L chassis and trim
 function conversion for 2-16
 function description for 2-4
 part numbers and drawings for 2-10
latch tube sleeve 2-22
latches 2-21
LL chassis and trim
 function conversion for 2-16
 function description for 2-5
 part numbers and drawings for 2-11
lock chassis
 aligning 3-11
 reinstalling in the door 3-10
 removing from the door 3-9
lubricating cores 3-10

N

N chassis and trim
 function description for 2-4
 part numbers and drawings for 2-12
N chassis assembly 2-12
numbers for parts
 see part numbers and drawings

P

P chassis and trim
 function description for 2-4
 part numbers and drawings for 2-13
part numbers and drawings
 for AB chassis and trim 2-6
 for assembly tools 2-22
 for B chassis and trim 2-7
 for D chassis and trim 2-8
 for E chassis and trim 2-9
 for knobs 2-19
 for L chassis and trim 2-10
 for latches 2-21
 for LL chassis and trim 2-11
 for N chassis and trim 2-12
 for P chassis and trim 2-13
 for R chassis and trim 2-14
 for roses, rose liners, and rose spacers 2-18
 for single dummy trim 2-20
 for strikes and strike boxes 2-17
 for throw member 2-19
 for Y chassis and trim 2-15

R

R chassis and trim
 function description for 2-3
 part numbers and drawings for 2-14
R chassis assembly 2-14
reinstalling
 bearing 3-6
 core 3-2
 inside button assembly 3-5
 inside rose and rose liner 3-7
 keyed knob 3-4
 lock chassis assembly 3-10

non-keyed knob 3-3
outside button assembly 3-5
outside rose and liner assembly 3-9

removing
 bearing 3-6
 button assembly 3-4
 core 3-2
 inside rose and rose liner 3-7
 knob 3-3
 lock chassis assembly 3-9
 outside rose and liner assembly 3-8

S

single dummy trim
 function description for 2-4
 part numbers and drawings for 2-20
strike plate locating pin 2-22 to 2-23
strikes and strike boxes 2-17
support, technical 1-2

T

technical documentation package 1-1
technical support 1-2
throw member 2-19
troubleshooting problems 3-12

Y

Y chassis and trim
 function description for 2-4
 part numbers and drawings for 2-15
Y chassis assembly 2-15
Y function rose assembly 2-15

