

# Installation Instructions for 45HW & 47HW Electrified Mortise Locks

## Contents

These installation instructions describe how to install your 45HW & 47HW Electrified Mortise Lock. Topics covered include:

- Finishing the door preparation* ..... 2
- Configuring and installing the mortise case* ..... 6
- Installing the trim* ..... 8
- Finishing the installation* ..... 13

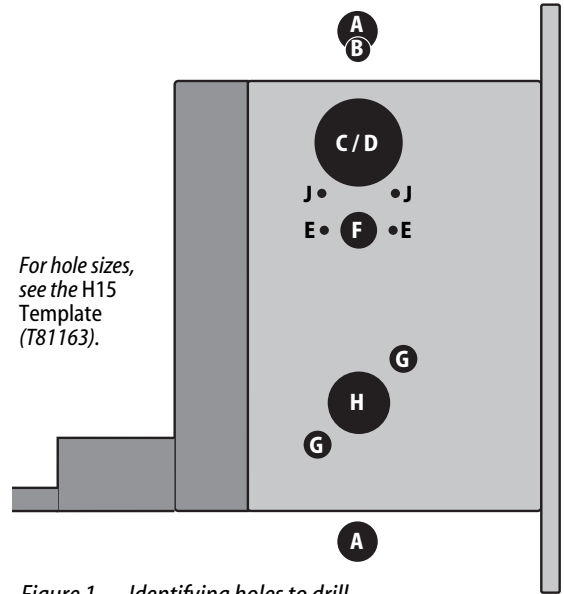
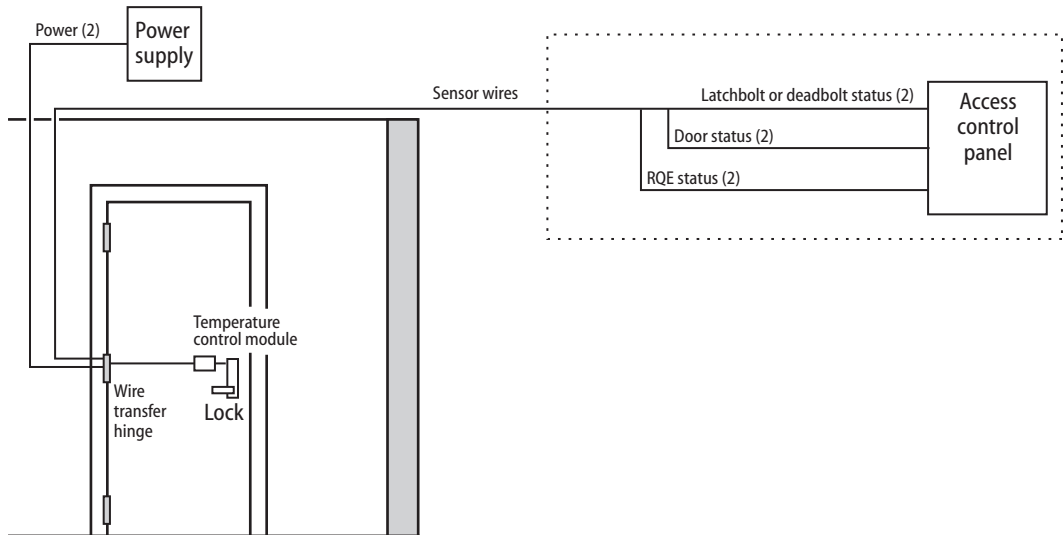

Figure 1 Identifying holes to drill



Wiring diagram for 45HW & 47HW Electrified Mortise Locks

## Finishing the door preparation

### Holes by Function

#### Functions

Holes to drill	DEL, DEU		TDEL, TDEU		TWEL, TWEU, WEL, WEU		LEL, LEU		NXEL, NXEU	
	I/S	O/S	I/S	O/S	I/S	O/S	I/S	O/S	I/S	O/S
<b>A</b> M & N forged trim (2 holes) <sup>†</sup>	Through door		Through door		Through door		Through door		Through door	
<b>B</b> J trim <sup>†</sup>	Through door		Through door		Through door		Through door		Through door	
<b>C</b> Standard cylinder or <b>D</b> High security cylinder <sup>‡</sup>		■		■	■	■				
<b>E</b> H, R & S trim thumb turn mounting screw (2 holes) <sup>†</sup>			■				■			
<b>F</b> Emergency key / thumb turn access			■				■	■		
<b>G</b> Trim mounting (2 holes) <sup>††</sup>	■	■	■	■	■	■	■	■	■	■
<b>H</b> Lever <sup>††</sup>	■	■	■	■	■	■	■	■	■	■

<sup>†</sup> Determine trim holes based on trim type.

<sup>‡</sup> To qualify for the UL 437 high security listing, use the M escutcheon and the 1E7J4 cylinder. The 1E7K4 cylinder is available for use with either M trim or sectional trim, but does not qualify for the UL437 high security listing.

<sup>††</sup> Because these holes pass through the mortise pocket, it is recommended that each hole be drilled separately rather than straight through.

## 1 Identify holes to drill

- 1 Determine the lock function to be installed.
- 2 Determine the inside and outside, hand, and bevel of the door.
- 3 See the Holes by Function table and Figure 1 on page 1 to determine the holes to be drilled for the lock function.

## 2 Align templates

**Note:** If the door is a fabricated hollow metal door, determine whether it is properly reinforced to support the lock. If door reinforcement is not adequate, consult the door manufacturer for information on proper reinforcement. For dimensions for preparing metal doors, see the H19 Template—Installation Specifications for 45HW & 47HW Electrified Mortise Locks (T81611).

- 1 Separate the 4 templates provided on the H15 Template—Installation Template for 45H & 47H Mortise Locks and 45HW & 47HW Electrified Mortise Locks (T81163).
- 2 Position one of the door edge templates on the door, making sure that the lock case mortise shown on the template aligns with the mortise pocket prepared in the door.
- 3 Using the centerlines on the door edge template as a guide, position the appropriate door template on each side of the door. You need to take the bevel into account. Tape the templates to the door.

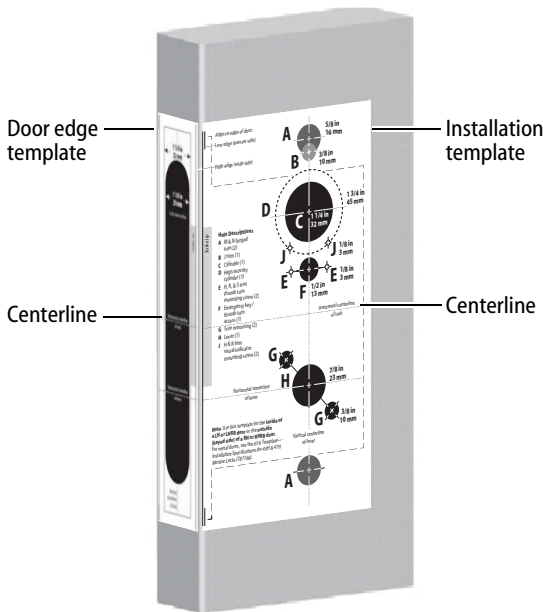

Figure 2 Aligning the templates

## Finishing the door preparation

### 3 Center punch and drill holes

- 1 Center punch the necessary drill points. See the instructions on the template.
- 2 Drill the holes.

**Note 1:** To locate the center of a hole on the opposite side of the door, drill a pilot hole completely through the door.

**Note 2:** For holes through the door, it is best to drill halfway from each side of the door to prevent the door from splintering.

### 4 Drill wire channel through door

**Caution 1:** Check with your local fire marshal before drilling a fire-rated door. Drilling through a fire-rated door may void the fire label.

**Caution 2:** Be careful to drill straight through the door, making sure the drill does not break through the face of the door.

- 1 Remove the hinge nearest the mortise cavity.
- 2 Extend the mortise pocket one inch as shown in Figure 4.
- 3 Drill a one inch diameter × three inch long hole at the base of the mortise pocket as shown in Figure 4.
- 4 Using a 3 to 4 foot drill bit, drill a 3/8" diameter channel from the base of the one inch diameter hole at the base of the mortise pocket to the center of the nearest hinge mortise as shown in Figure 4.

**Note:** It may be easier to drill halfway from each side of the door.

### 5 Prepare door for door status switch (optional for deadbolt function locks)

- 1 Locate the centerpoint for the door status switch 2.5" above the top of the faceplate mortise on the edge of the door (as shown in Figure 5).
- 2 Drill a 1" diameter hole 1 3/4" deep for the door status switch.
- 3 Position the drill so the tip of the bit is approximately 1" into the hole and the bit is close to the top edge of the hole. Then drill a 3/8" channel at approximately a 35° angle from the door status switch hole into the mortise cavity (as shown in Figure 5).

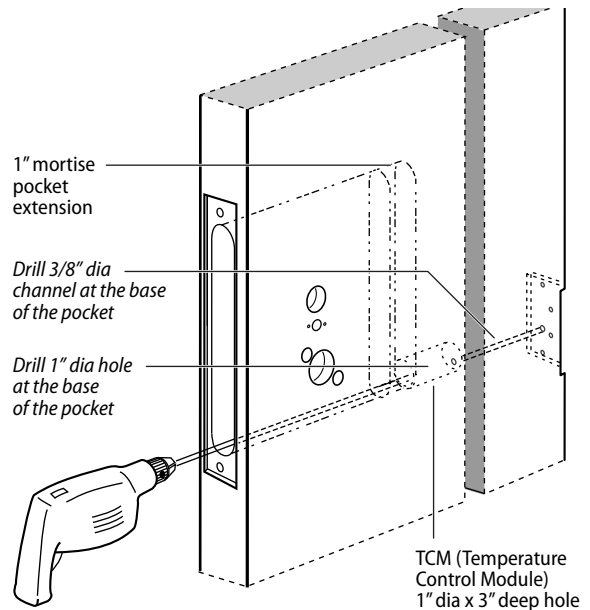

Figure 4 Drilling the wire channel through the door

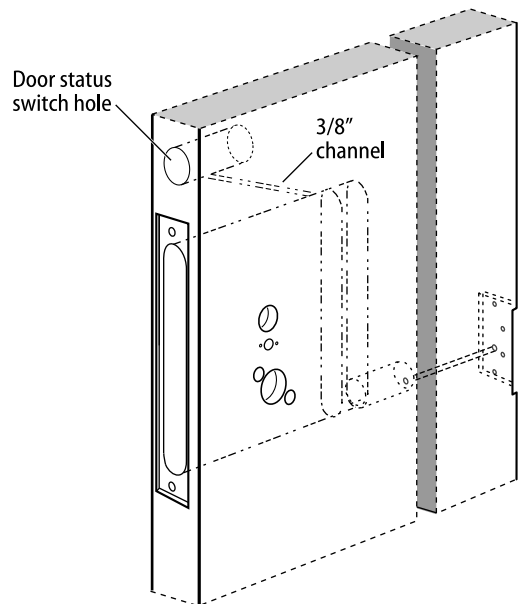

Figure 5 Preparing for the door status switch

## Finishing the door preparation

### 6 Determine wire gauge for power wiring

- Calculate the total length of the power wire run by summing:
  - The distance from the power supply to the first door.
  - If powering more than one door daisy-chained to the same power supply, add the total distance of the power runs between the doors.
- For both 12 volt and 24 volt locks, refer to the table below to determine the minimum wire gauge based on the number of doors sharing the power supply and the total length of the wire run.

1 door	2 doors	3 doors	4 doors	Min. wire gauge
250 ft.	125 ft.	75 ft.	60 ft.	18 AWG
400 ft.	200 ft.	130 ft.	100 ft.	16 AWG
600 ft.	300 ft.	185 ft.	150 ft.	14 AWG

### 7 Prepare door for wire transfer hinge and run field wiring

- Drill a wire access hole through the frame side of the hinge mortise where you removed the hinge in Task 4, Step 1 on page 3.
- Drill holes (or pockets) for splice connectors in the frame and door. Refer to the hinge manufacturer's specifications for the hole location.
- De-burr the holes to prevent damage to the hinge leads.
- Run the power field wiring from the location for the lock's power supply to the location for the wire transfer hinge.
 

**Note:** To match the lock's wire color, use yellow for 12 volts DC power and blue for 24 volts DC power.
- If the lock has an optional door status sensor, latchbolt status sensor, deadbolt status sensor, and/or RQE status sensor, run the sensor wiring from the location of the access control panel to the location for the wire transfer hinge.

(Continued)

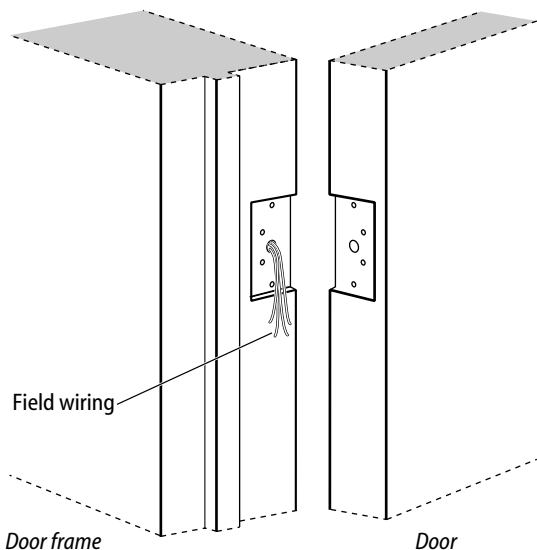

Figure 7 Running field wiring

## Configuring & installing the mortise case

To match the sensor wire colors, refer to the table below.

Wire Connection	Color	No. of Wires	Type
24V Power	Blue	2	Power
12V Power	Yellow	2	Power
Door Status Sensor	White	2	NO†
Latchbolt Status Sensor	Violet	2	NC‡
RQE Status Sensor	Brown & Orange	(2) Sets - 4 wires*	NO†

\* Only 2 wires used at hinge see Page 6, Step 10, Notes 1 & 2 for explanation

† Normally Open

‡ Normally Closed

- Pull the field wiring down the wall and through the access hole in the frame.

### 8 Install door status switch (optional for deadbolt function locks)

- Position the shield on the door status switch with the notch facing downwards (towards the mortise pocket).

**Caution:** Make sure the wires are not routed across any sharp edges or over any surface that could damage its sleeving.

- Feed the wires for the door status switch into the door status switch hole and through the channel into the mortise cavity.
- Insert the door status switch assembly into the door status switch hole.

### 9 Rotate latchbolt (if necessary)

- Determine whether you need to rotate the latchbolt to match the handing of the door.

**Note:** The angled surface of the latchbolt must contact the strike when the door closes.

- If you need to rotate the latchbolt, insert a flat blade screwdriver into the latch access point approximately 1/2" into the case and press to extend the latch out of the case (Figure 9).
- Rotate the latchbolt past 180 degrees, keeping constant pressure on it. Then allow it to retract into the case.

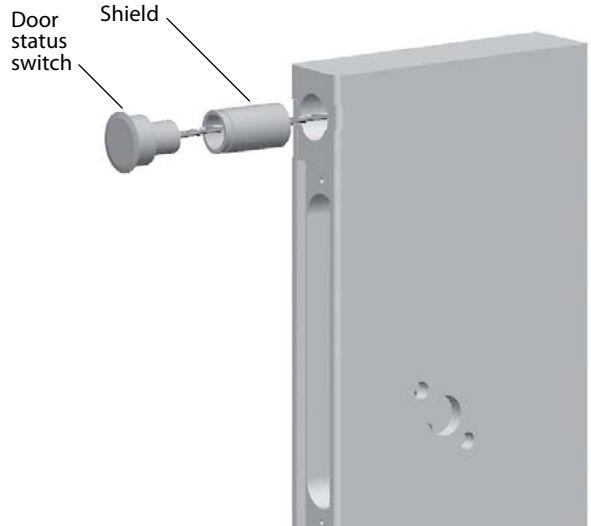

Figure 8 Installing the door status switch

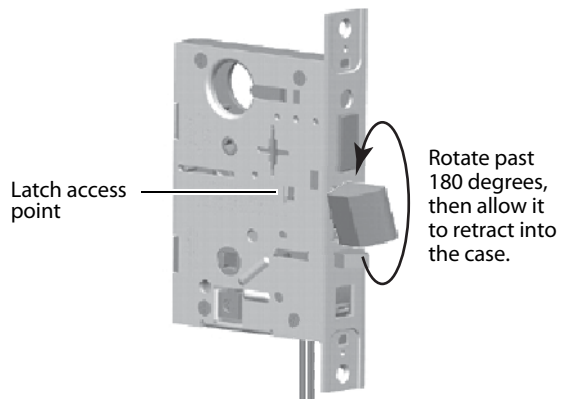

Figure 9 Rotating the latchbolt

## Configuring & installing the mortise case

### 10 Position hub toggles (if necessary)

- 1 Check whether the hub toggles are in the proper position for the lock (Figure 10). The inside hub toggle should be down (always latched) and the outside hub toggle should be up (lockable).

**Note 1:** For LH & LHRB doors, the inside is the back side of the case and the outside is the cover side of the case. For RH & RHRB doors, the inside is the cover side of the case and the outside is the back side of the case. The cover is mounted to the case with 4 screws.

**Note 2:** If the lock has an optional RQE status sensor, two RQE status switches are installed in the mortise case. However, only the switch for the inside of the lock needs to be connected. Before you install the mortise case in the door, determine whether you need to connect the 'Case Side' pair of RQE wires (LH & LHRB) or the 'Cover Side' pair of RQE wires (RH & RHRB), based on the handing of the door. (See door handing chart to the left for reference).

- 2 To change the position of a hub toggle, remove the toggle screw, move the toggle into the desired position, and re-tighten the screw.

### 11 Connect Temperature Control Module

- 1 Connect the Temperature Control Module (TCM) to the lock as shown in Figure 11.
- 2 Fish the TCM wires through the door channel, making sure to position the TCM inside the one inch diameter hole extension at the base of the mortise cavity as shown in Figure 11. See also Figure 4.

**Note:** In some door applications (for example fire doors), it may not be possible to make extra holes into the door. In such scenarios, the TCM may be installed in a secure location at no more than 20 feet from the door.

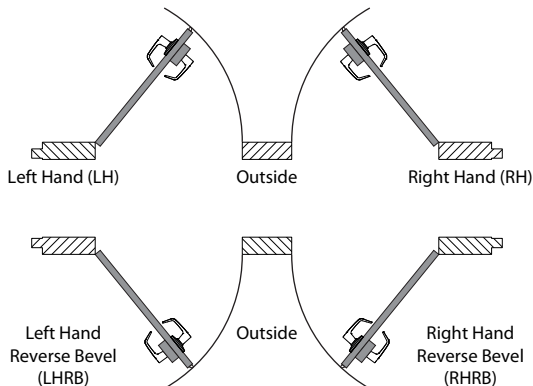

Door handing chart

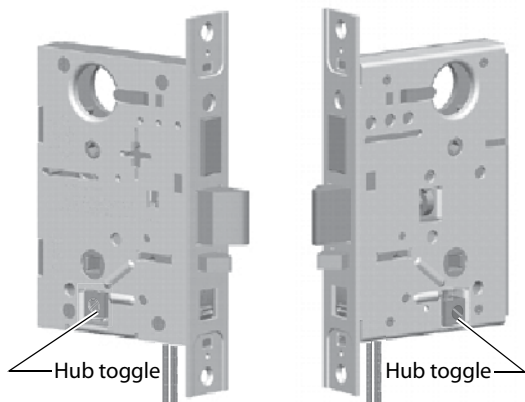

Figure 10 Positioning the hub toggles

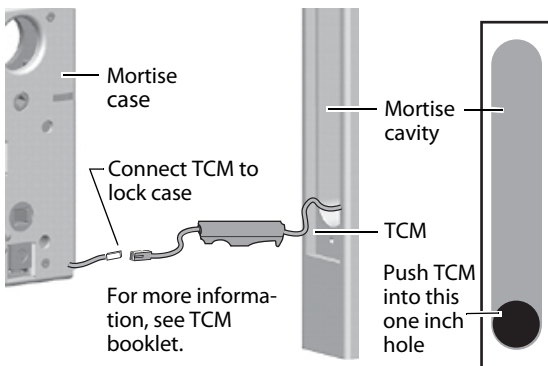

Figure 11 Connecting and positioning TCM

## Configuring & installing the mortise case

### 12 Install mortise case

- 1 Drill the holes for the case mounting screws.
- 2 Insert the mortise case into the mortise cavity, feeding all sensor and solenoid wires into the mortise cavity.

**Note:** *The armored front of the mortise case self-adjusts to the door bevel.*

- 3 From the hinge edge of the door, fish all sensor and solenoid wires from the mortise cavity through the wire channel to the hinge mortise.
- 4 Secure the mortise case with the case mounting screws (Figure 12).

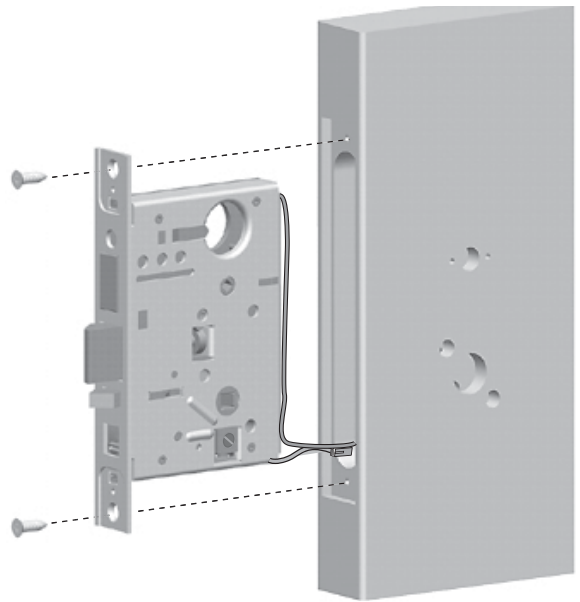

Figure 12 Installing the mortise case

### 13 Install wire transfer hinge

**Note:** *Stanley recommends one of the following concealed electric hinges from Stanley Security Solutions. For more information, contact your Stanley representative.*

Hinge	Description†
CECB 179-66	Standard weight; steel
CECB 168-66	Heavy weight; steel
CECB 191-66	Standard weight; brass

† All hinges measure 4.5" × 4.5" and have a 26D finish. All hinges have two 24 AWG wires rated for 2 A at 12 or 24 volts (AC or DC) and four 28 AWG wires rated for 1 A at 12 or 24 volts (AC or DC).

- 1 Trim the power and sensor wires that you pulled through the hinge edge of the door. Leave sufficient length to connect to the wire transfer hinge and to allow for future splices.
- 2 Splice the field wires to the leads on the frame side of the hinge, following the hinge manufacturer's instructions.
- 3 Splice the power and sensor wires from the lock to the leads on the door side of the hinge, matching each lead to its corresponding wire.

**Note:** *If the lock has an optional RQE status sensor, splice only the pair of RQE wires for the switch on the inside of the door, which you identified in Task 10 on page 6. Put the unused pair of RQE wires in the door.*

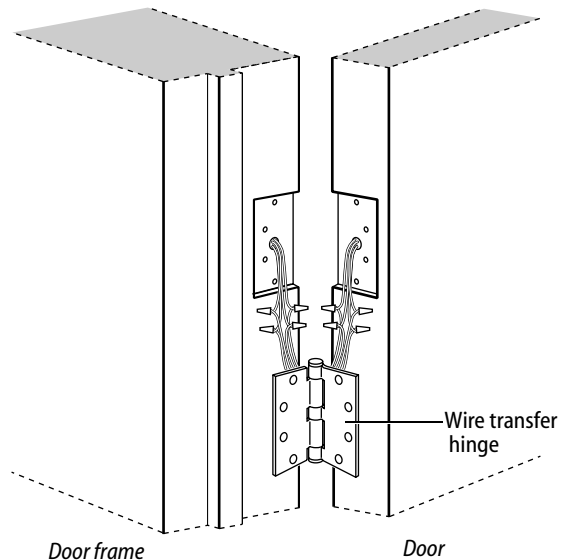

Figure 13 Installing the wire transfer hinge

## Installing the trim

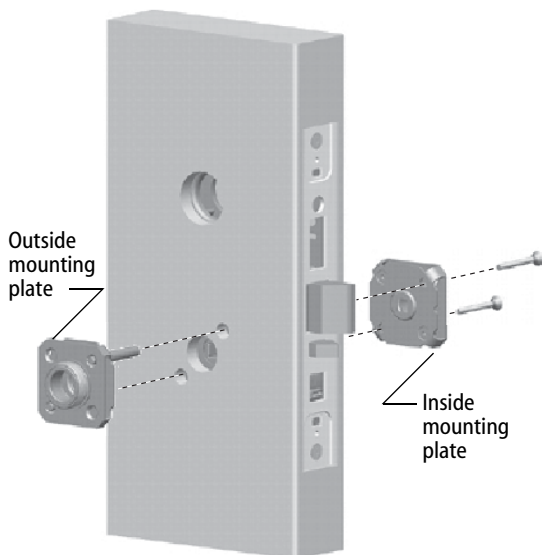

Figure 14 Installing the trim mounting plates

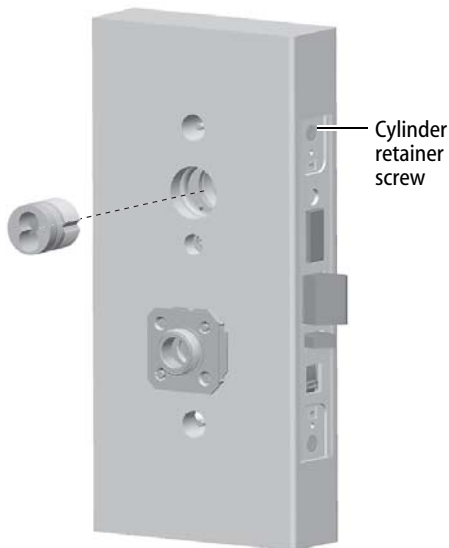

Figure 15 Installing the concealed cylinder

- 4 Insert the wires and splice connectors into the holes or pockets in the door and frame, being careful not to pinch the wires. Install the wire transfer hinge.

### 14 Install trim mounting plates

- 1 For *J trim*, position the J alignment plate (Figure 16b) on the outside of the door.
- 2 For all trim, insert the outside trim mounting plate through the door and mortise case.
- 3 Position the inside trim mounting plate opposite the outside trim mounting plate and screw them securely in place.

**Caution:** Do not overtighten the trim mounting plate screws. Overtightening may damage the locking mechanism.

### 15 Install concealed cylinder (*N trim only*)

- 1 Use a cylinder wrench to thread the cylinder into the mortise case so that the groove around the cylinder is even with the door surface.  
**Caution:** A malfunction can occur if the cylinder is threaded in too far.
- 2 Secure the cylinder in the mortise case with the cylinder retainer screw.



## Installing the trim

### 16 Install roses or escutcheons

For sectional trim (Figure 16a)

- 1 Position the inside rose on the door so it is centered on the trim mounting plate.
- 2 Use the spanner wrench to install the rose ring onto the inside mounting plate.
- 3 Position the outside rose on the door so it is centered on the trim mounting plate.
- 4 Use the spanner wrench to install the rose ring onto the outside mounting plate.

For J trim (Figure 16b)

- 1 Position the inside escutcheon on the door so it is centered on the trim mounting plate. Install the escutcheon screw.
- 2 Use the spanner wrench to install the trim ring onto the inside mounting plate.
- 3 Position the outside escutcheon on the door over the alignment plate.
- 4 Use the spanner wrench to install the trim ring onto the outside trim mounting plate.

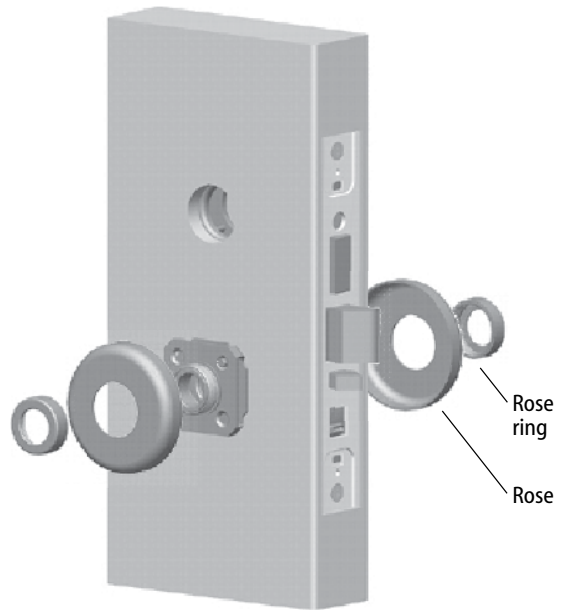

Figure 16a Installing the roses

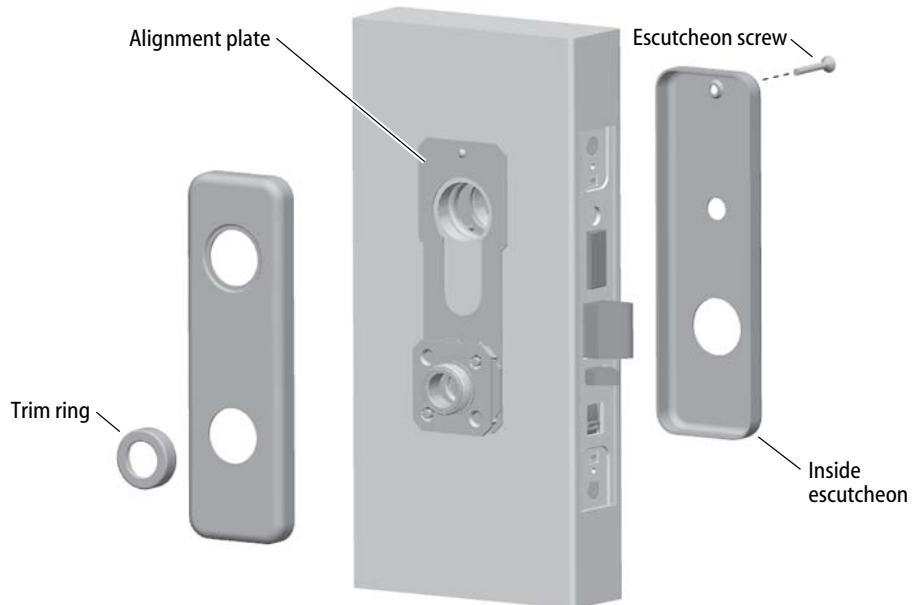

Figure 16b Installing the J trim escutcheons

## Installing the trim

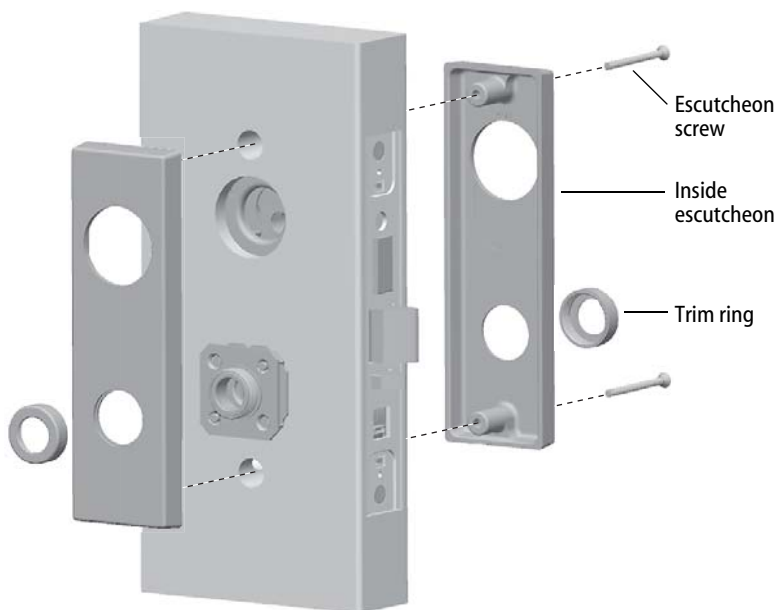

Figure 16c Installing the M trim escutcheons  
(47H M trim shown)

For M trim (Figure 16c) or N trim (Figure 16d)

- 1 Position the inside and outside escutcheons on the door so they are centered on the trim mounting plates.
- 2 Install the upper and lower escutcheon screws from the inside of the door.
- 3 Use the spanner wrench to install the trim rings onto the inside and outside trim mounting plates.

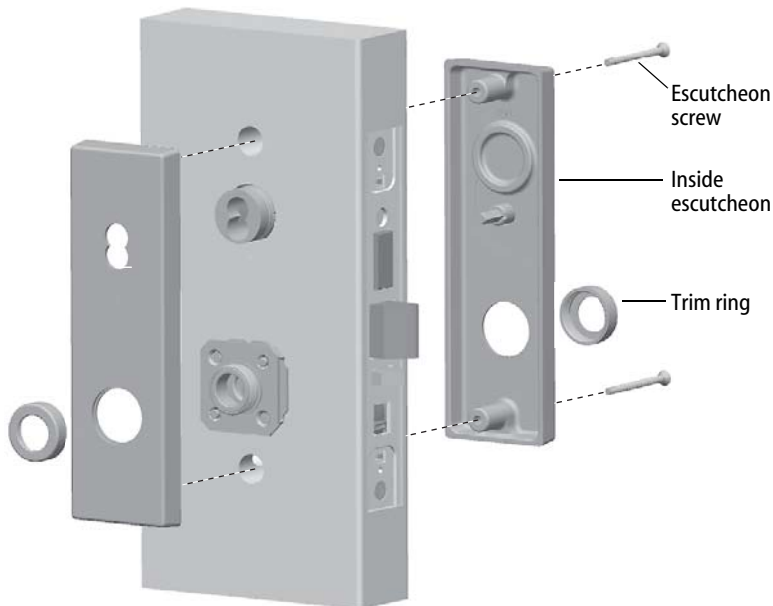

Figure 16d Installing the N trim escutcheons

## Installing the trim

### 17 Install thumb turn or emergency access plate (if necessary)

**Note 1:** Install the thumb turn on the inside of the door for the following lock functions:

- TDEL    ■ TDEU
- LEL     ■ LEU

**Note 2:** Install the emergency access plate on the outside of the door for privacy function (LEL and LEU) locks.

- 1 Orient the thumb turn so it points up when the deadbolt is retracted and towards the hinge edge of the door when the deadbolt is extended.
- 2 Install the thumb turn or emergency access plate using the two screws provided (Figure 17).

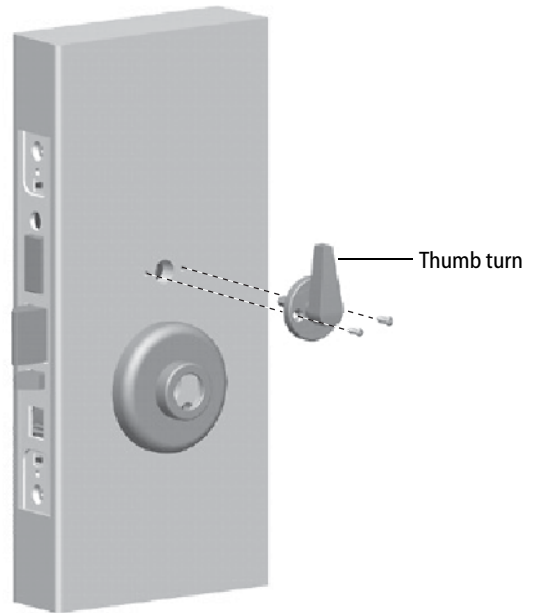

Figure 17 Installing the thumb turn or emergency access plate

## Installing the trim

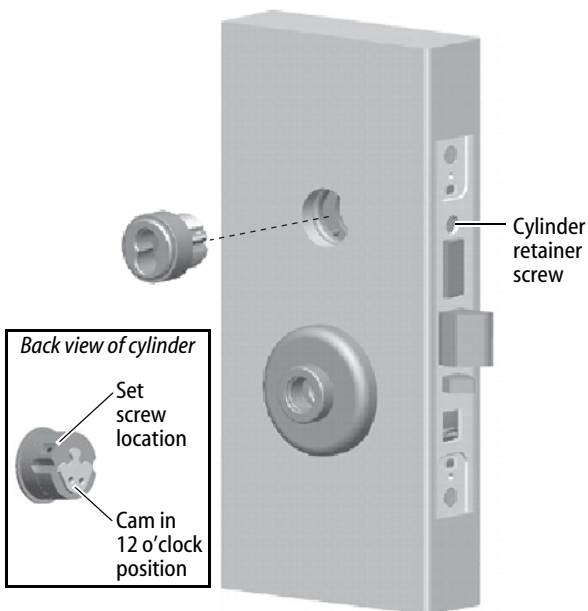

Figure 18a Installing the standard cylinder

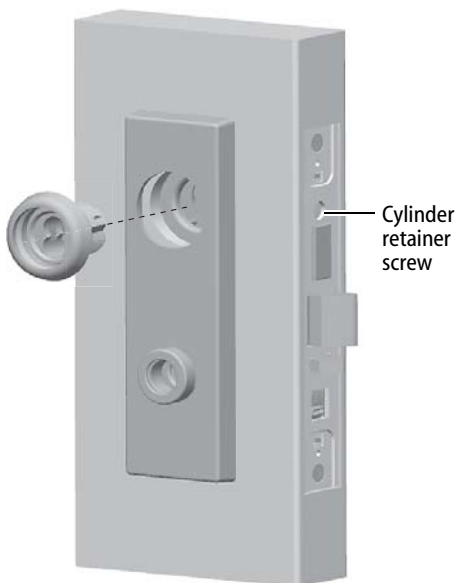

Figure 18b Installing the high-security cylinder

### 18 Install standard or high security cylinder (if necessary)

- 1 Using a narrow-blade screwdriver, insert the blade into the cylinder's figure-8 opening and back the set screw into the cylinder until the tip of the set screw is below the threads of the cylinder.
- 2 Make sure the washer (standard cylinder only) and cylinder ring are positioned on the cylinder.
- 3 Rotate the cylinder cam to the 12 o'clock position.
- 4 Use a cylinder wrench to thread the cylinder into the mortise case.

*For a standard cylinder, rotate the cylinder until the cylinder ring is flush against the door.*

*For a high-security cylinder, rotate the cylinder until the cylinder head touches the inside rim of the cylinder ring.*

**Caution: A malfunction can occur if the cylinder is threaded in too far.**

- 5 Using a narrow-blade screwdriver, insert the blade into the figure-8 opening and tighten the small set screw (installed in the cylinder) into the lock case.
- 6 Secure the cylinder in the mortise case with the cylinder retainer screw.

## Finishing the installation

### 19 Install inside and outside levers

For standard lever installation (Figure 19)

- 1 Unscrew the inside spindle one full turn to allow the spindles to turn freely.  
**Note:** Remove the label from the inside spindle.
- 2 With the handle pointing toward the door hinges, insert the outside lever and spindle assembly into the lock from the outside of the door.  
**Note:** The 17 style lever is handed. The lever should curve downward when installed on the door.
- 3 Slide the inside lever onto the inside spindle and secure it with the set screw.
- 4 Turn the levers to check that they operate smoothly.

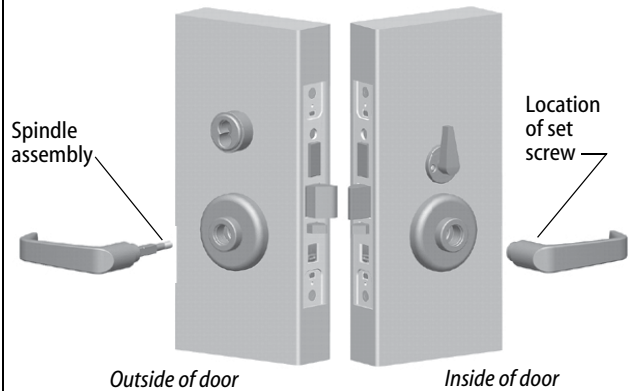

Figure 19 Installing the levers

### 20 Install mortise case faceplate

- 1 Secure the mortise case faceplate to the mortise case with the faceplate mounting screws.
- 2 Check the lock for proper operation.

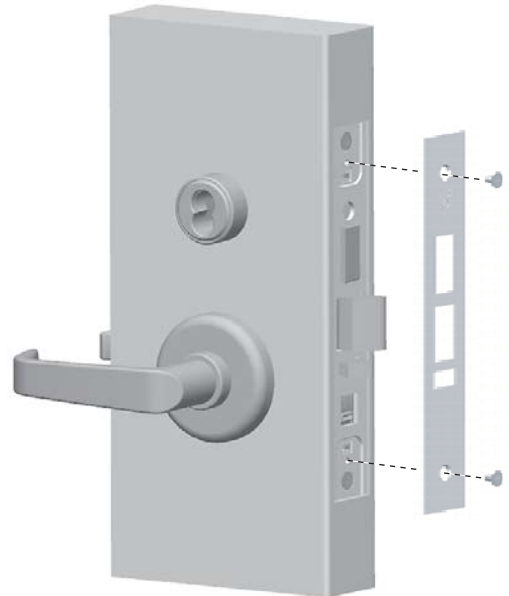

Figure 20 Installing the mortise case faceplate

## Finishing the installation

### 21 Install strike box and strike plate

- 1 If the door jamb has not been mortised for the strike box and strike plate, perform these steps:
  - a On the door jamb, locate the horizontal centerline of the strike (3/8" above the centerline of the lock), as well as the vertical centerline of the strike.
  - b Mortise the door jamb to fit the strike box and strike plate.
  - c Drill the holes for the screws used to install the strike box and strike plate.
- 2 If using a strike box with a magnet (for the optional door status sensor), orient the strike box so that the magnet is at the top of the strike box.
- 3 Insert the strike box into the mortise in the door jamb. Place the strike plate over the strike box and secure the strike with the screws provided.
- 4 Check the position of the auxiliary bolt against the strike plate.

**Note:** The recommended gap between the door and jamb is 1/8" .

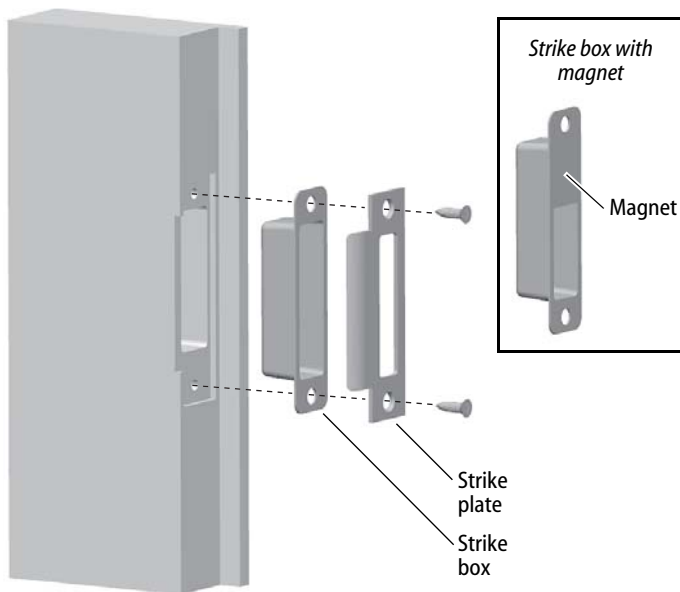

Figure 21 Installing the strike box and strike plate

## Finishing the installation

### 22 Install door status magnet (optional for deadbolt function locks)

- 1 On the door jamb, mark the drill point for the door status magnet hole.  
**Note:** This hole should be directly opposite the door status switch when the door is closed.
- 2 Drill a 1" diameter hole for the magnet, at least 1 3/4" deep.
- 3 Insert the magnet into the hole.

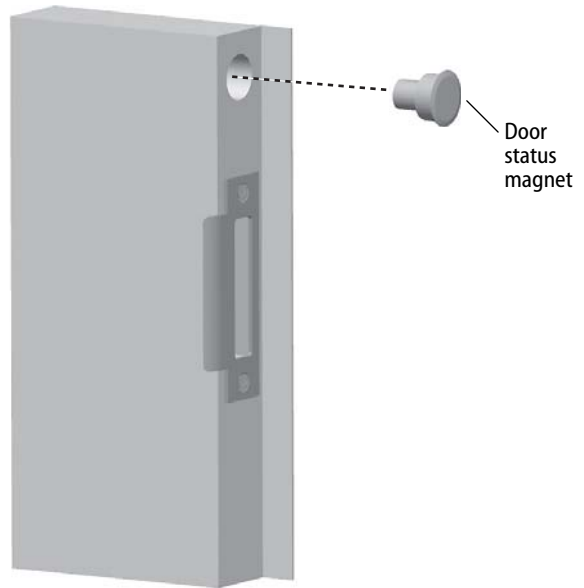

Figure 22 Installing the door status magnet

### 23 Install cores

- 1 For a high-security cylinder, slide the cylinder face down over the core.
- 2 Insert the control key into the core and rotate the key 15 degrees to the right.
- 3 With the control key in the core, insert the core and cylinder face (high-security cylinder only) into the cylinder.
- 4 Rotate the control key 15 degrees to the left and withdraw the key.

**Caution:** The control key can be used to remove cores and to access doors. Provide adequate security for the control key.

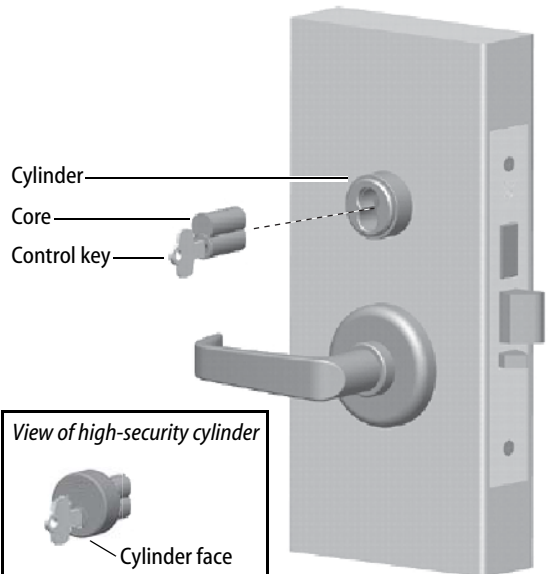

Figure 23 Installing the core(s)

## Finishing the installation

### 24 Install lock power supply

Determine the power supply requirements for the lock.

- For a lock with a 12 volt solenoid, use a regulated power supply rated for 12 volts DC at 1.1 amps.
- For a lock with a 24 volt solenoid, use a regulated power supply rated for 24 volts DC at 0.75 amps.
- To power more than one lock with the same power supply, sum the total volt-amps (power) for the circuit and then multiply that number by 1.5. This is the minimum power rating in volt-amps recommended for the power supply.

#### Example for two locks powered by one supply:

*Both locks are rated at 12 volts, 1.1 amps*

*$(12 \text{ volts} \times 1.1 \text{ amps}) + (12 \text{ volts} \times 1.1 \text{ amps}) = 26.4 \text{ volt-amps}$*

*$26.4 \text{ volt-amps} \times 1.5 = 39.6 \text{ volt-amps}$*

*Choose a power supply with a rating of 39.6 volt-amps or higher.*

### 25 Make sensor connections

Connect the field wiring for the lock sensors to the access control panel.

Refer to the table below and the manufacturer's instructions for the access control panel.

Wire Connection	Color	No. of Wires	Type
24V Power	Blue	2	Power
12V Power	Yellow	2	Power
Door Status Sensor	White	2	NO†
Latchbolt Status Sensor	Violet	2	NC‡
RQE Status Sensor	Brown & Orange	(2) Sets - 4 wires*	NO†

\* Only 2 wires used at hinge see Page 6, Step 10, Notes 1 & 2 for explanation

† Normally Open

‡ Normally Closed

### 26 Check operation

- 1 Supply power to the lock and check its operation. For example, check that:
  - door latches and opens properly
  - deadbolt operates properly
  - key access works
  - door gap is 1/8"
  - auxiliary bolt is held inside the case when the door is closed.
- 2 When installation of the access control system has been completed, apply power to the system and check that the door's sensors operate properly.

For assistance, contact your local Stanley representative.