

Installation Instructions

BES-0563 and BES-0563LM

Surface Mounted RIM Strike



Spanish and French translations are available on www.bestaccess.com
 Traducciones al español y francés están disponibles en www.bestaccess.com
 Des traductions en espagnol et en français sont disponibles sur www.bestaccess.com

Installations of this RIM strike, qualify as "Indoor Use Only", when not continuously exposed to an outdoor environment.

Important:

- Ensure the listed exit device functions as intended for life safety concerns by verifying electric strike and exit device compatibility.
- Maximum latch projection is essential to obtain full holding force. Use 1/8" spacers to maximize latch contact.
- The strike and all devices connected to it, shall be installed with wires less than 30m in length.
- When installed in a Fail Secure manner, the local Authority Having Jurisdiction shall be consulted with regards to the use of selected panic hardware to ensure emergency exit from the secured area.

Catalog Specifications

MODEL	MODE	VOLTAGE	DUTY	AVERAGE CURRENT
BES-0563 / BES-0563LM	Fail Secure / Fail Safe	12.7-24VDC Auto-Sensing	Continuous	19mA @12.7VDC * 26mA @24VDC *

DC = Direct Current
 *Peak Current: 153mA @12.7VDC
 298mA @24VDC

Instructions

1. Carefully prepare the frame per template A89081.
2. Test fit electric strike to ensure full latch engagement.
Add provided spacers, if required.
3. Set Fail Secure or Fail Safe mode using the dip switch identified on the strike. Factory set to Fail Secure.
NOTE: Strike must be cycled once for change to take effect.
- 4a. Make wire connections from the power source to the wire harness supplied.
- 4b. Make wire connection for monitoring latch (BES-0563LM only).
Black: Common
Blue: Normally Closed (NC)*
Orange: Normally Open (NO)*
*with door open

SPDT Switch: 1A resistive 24VDC

Typical Fail Secure Application

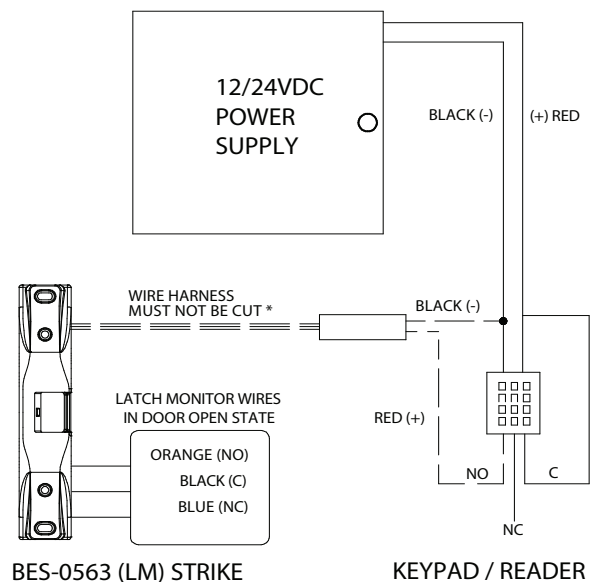

* Please contact BEST for proper wiring support if these wires are cut

- Mount the electric strike with 1/4-20 UNC screws provided in the horizontal adjustment mounting holes (the outer slots). Adjust electric strike horizontally until exit device latch fully engages with the door closed.

NOTE: Ensure a 1/16" (1.5mm) clearance between exit device latch and the electric strike keeper is maintained. Failing to do so will preload the strike and in turn, will not allow the strike to release the door when energized.

WARNING: For proper operation a minimum gap of 1/8" (3.2mm) is required between latch and back of strike. If gap is less than 1/8" (3.2mm), the latch will jam and the keeper won't rotate.

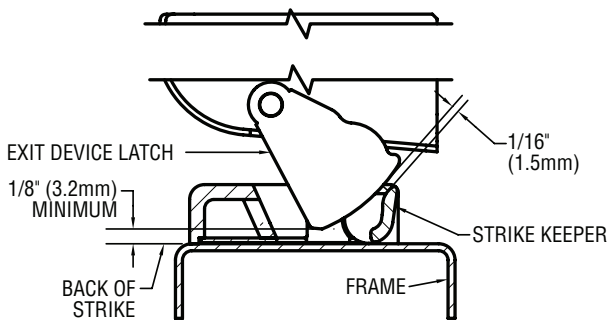

- Tighten the two mounting screws and check operation. Adjust the horizontal position of electric strike as required.
- Use the electric strike as a template to mark the two lock down holes. Remove strike. Drill & tap for 1/4-20 UNC locking screws. Using the 1/4-20 UNC screws provided, secure the electric strike through the lock down holes.

Dimensional Details

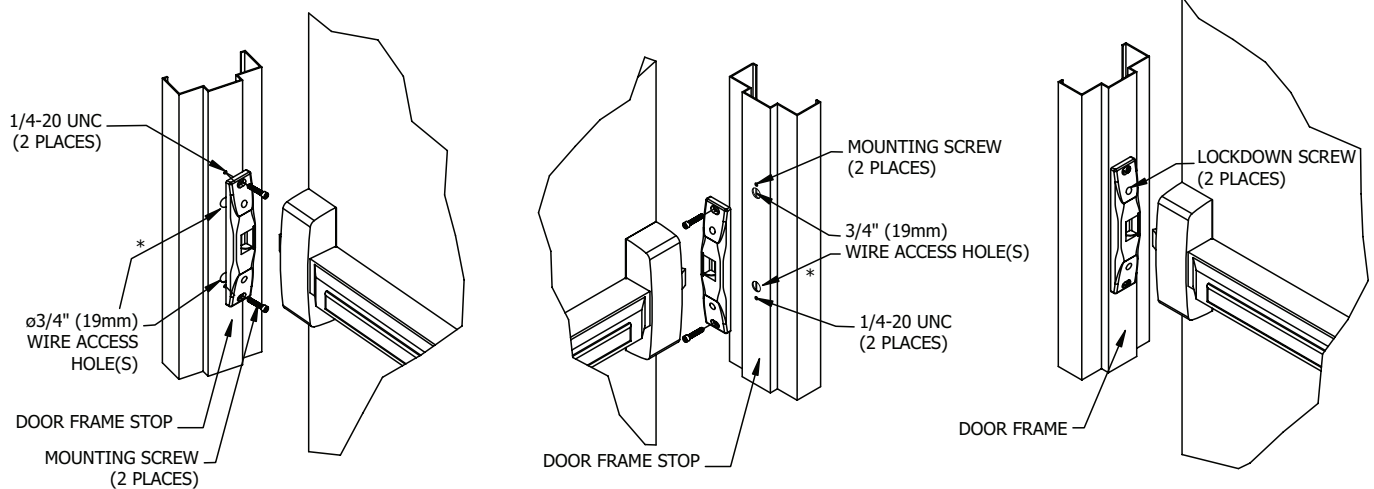
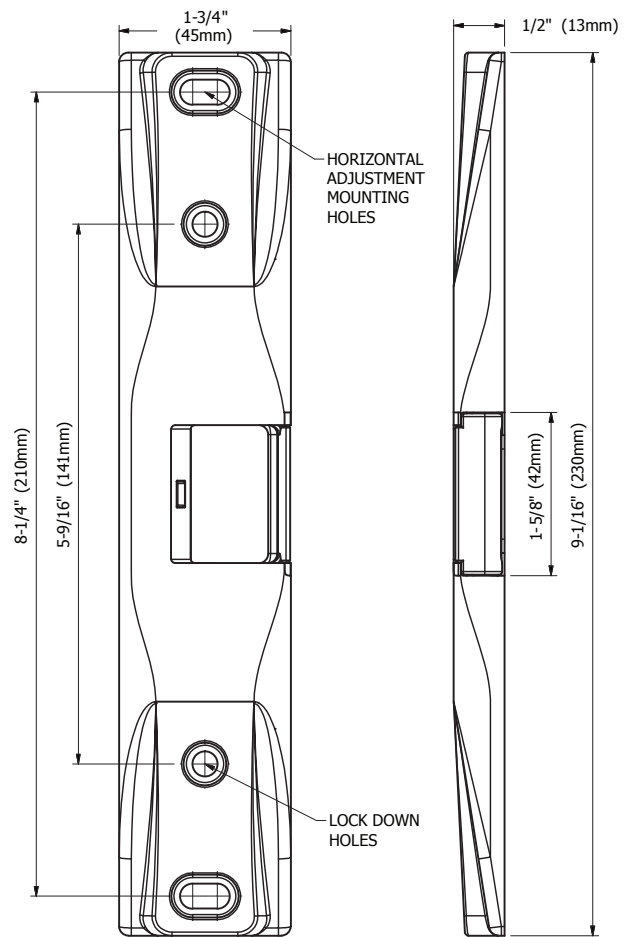

*Second wire access hole required for BES-0563LM model only.

NOTE: Not to scale. Specifications are subject to change without notice.