

## Planning the installation

### Contents

These installation instructions describe how to install your Offline G/V Series or Keypad EZ (83KZ or 93KZ) Cylindrical Locks. Topics covered include:

<i>Planning the installation</i> .....	1
<i>Preparing the door and door jamb</i> .....	2
<i>Installing the lock</i> .....	6
<i>Completing the installation</i> .....	12

### Site survey

Use the following survey to record information about the installation site. You need this information to determine how to prepare the door for the lock.

#### Door information

Door handing and bevel:

- Left hand (LH)
- Left hand, reverse bevel (LHRB)
- Right hand (RH)
- Right hand, reverse bevel (RHRB)

Door thickness: \_\_\_\_\_ inches (1 3/4" to 2 1/4")

#### Environment information

Ambient temperature:

- Is within specifications. See the tables below.

This product meets the following Locked Door Outdoor test requirements for ANSI/BHMA 156.25:

Side of door	Range
Inside	+66°F to +74°F (+19°C to +23°C)
Outside	-31°F to +151°F (-35°C to +66°C)

This product meets the following Full Indoor test requirements for ANSI/BHMA 156.25:

Side of door	Range
Inside and outside	+32°F to +120°F (0°C to +49°C)

### Components checklist

Use the following checklist to make sure that you have the items necessary to install your Electronic Stand-alone Cylindrical Lock.

#### Components provided in the box:

- Chassis with outside lever or knob and outside rose liner assembly
- Top and bottom inside covers
- Fire plate
- Battery holder with batteries
- Inside rose liner
- Outside escutcheon assembly
- Inside lever or knob
- Throw member package\*
- Sleeve bushing\*
- Latch
- Hub washers
- Trim hole insert package
- Plastic bushing package
- Escutcheon screw package
- Strike package
- Bar code ID sticker (for your records)
- Installation template and instructions

#### Other components:

- Core
- Control key
- Temporary operator card (Offline G/V Series Locks only)

### Special tools checklist

Use the following checklist to make sure that you have the special tools necessary to install your Electronic Stand-alone Cylindrical Lock.

- KD303 Drill jig (for use with 93KG, 93KBV, or 93KZ only)
- T20 TORX® bit driver
- KD325 Strike plate locating pin
- KD315 Faceplate marking chise

\*Patent Pending

## Preparing the door and door jamb

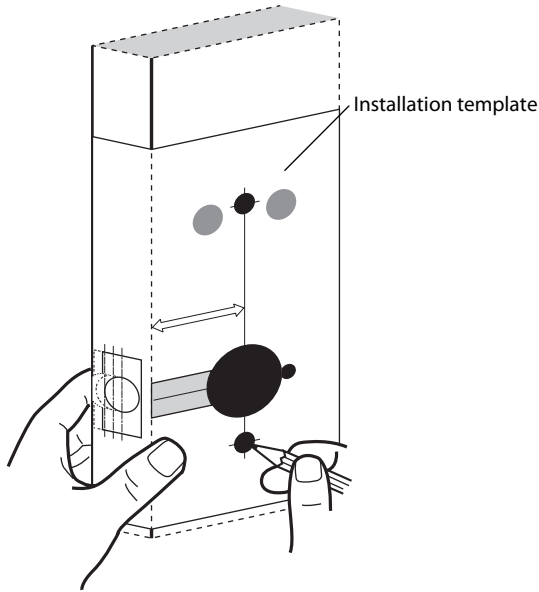

Figure 5 Positioning the template

### 1 Position template and mark drill points

**Note:** If the door is a fabricated hollow metal door, determine whether it is properly reinforced to support the lock. If door reinforcement is not adequate, consult the door manufacturer for information on proper reinforcement. For dimensions for preparing metal doors, see the G01 and G02 Templates—Installation Specifications for 83/93KG, 83/93KBV, 83/93KN and 83/93KZ Cylindrical Locks.

**Note:** If the door is a LH or RH door, mark the inside of the door. If the door is a LHRB or RHRB door, mark the outside of the door.

#### For uncut doors and frames

- 1 Measure and mark the horizontal centerline of the lever (the centerline for the chassis hole) on the door and door jamb. Mark the vertical centerline of the door edge.

**Note:** The recommended height from the floor to the centerline of the crossbore or chassis hole is 38".

- 2 Fold the G05 Template—Installation Template for 83/93KG, 83/93KBV, 83/93KN and 83/93KZ Cylindrical Locks on the dashed line and carefully place it in position on the high side of the door bevel.

**Note:** For steel frame applications, align the template's horizontal centerline for the latch with the horizontal centerline of the frame's strike preparation.

- 3 Tape the template to the door.
- 4 Center punch the necessary drill points. Refer to the instructions on the template.

#### For doors with standard cylindrical preparation

- 1 Fold the G05 Template—Installation Template for 83/93KG, 83/93KBV, 83/93KN and 83/93KZ Cylindrical Locks on the dashed line. Looking through the hole from the opposite side of the door, align the template so that you see the template outline of the 2 1/8" diameter chassis hole.
- 2 Tape the template to the door.
- 3 Center punch the necessary drill points. Refer to the instructions on the template.

## Preparing the door and door jamb

### 2 Drill holes and mortise for latch face

1 Drill the holes listed below:

■ **upper and lower trim holes**

- ◆ 5/8" diameter
- ◆ through door

■ **harness hole**

- ◆ 3/4" diameter
- ◆ through door
- ◆ location based on handing

■ **motor wire hole**

- ◆ 7/16" diameter
- ◆ through door
- ◆ before drilling chassis hole

■ **chassis hole**

- ◆ 2 1/8" diameter
- ◆ through door

- ◆ after drilling motor wire hole

■ **latch hole**

- ◆ 1" diameter
- ◆ meets chassis hole

**Note 1:** To locate the center of a hole on the opposite side of the door, drill a pilot hole completely through the door.

**Note 2:** For holes through the door, it is best to drill halfway from each side of the door to prevent the door from splintering.

2 Mortise the edge of the door to fit the latch face.

3 Drill the holes for the screws used to install the latch.

### 3 Optional: Keypad EZ Locks only: Prepare for remote unlock installation

If you want to be able to operate the Keypad EZ Lock remotely, that is from a momentary push-button switch, see *Installation Instructions for Keypad EZ Remote Unlock (T80922)* for complete instructions.

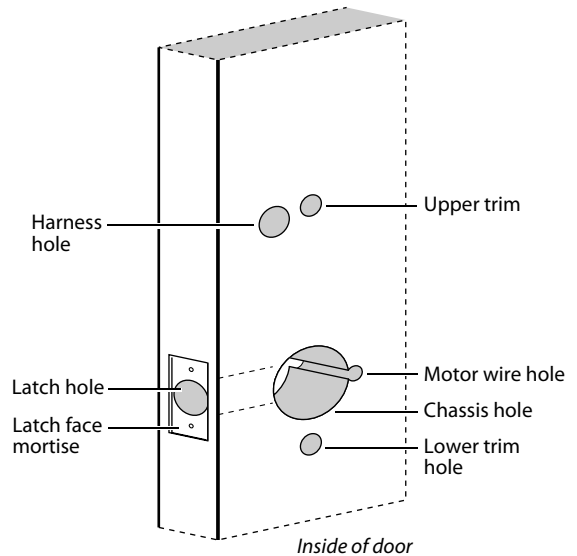

Figure 2 Drilling holes and mortising for the latch face

## Preparing the door and door jamb

### 4 Install latch

- 1 Install the latch in the door.

**Note:** The latch tube prongs should be centered and should project into the chassis hole.

- 2 Check that the door swings freely.

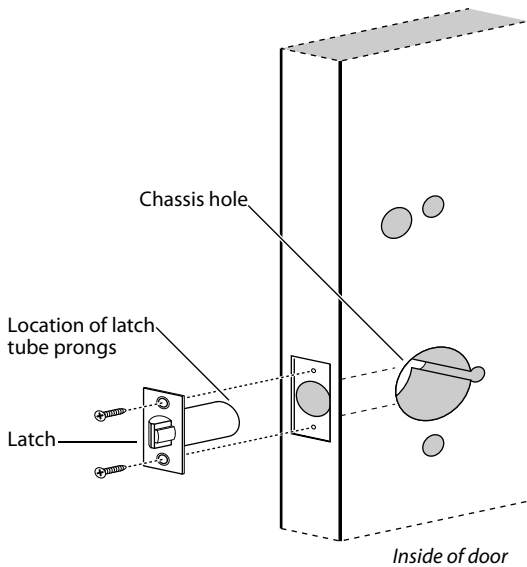

Figure 4 Installing the latch in the door

### 5 Optional: For 93KG, 93KBV and 93KZ only: Use drill jig to drill through-bolt holes

- 1 Press the drill jig (KD303) onto the door, engaging it with the latch tube prongs (see the close-up in Figure 5). Make sure the front edge of the jig is parallel with the door edge.
- 2 Drill the through-bolt holes (5/16" diameter) halfway into the door.
- 3 Turn over the drill jig and repeat steps 1 and 2 from the opposite side of the door.

**Note:** Replace the drill jig after 10 door preparations.

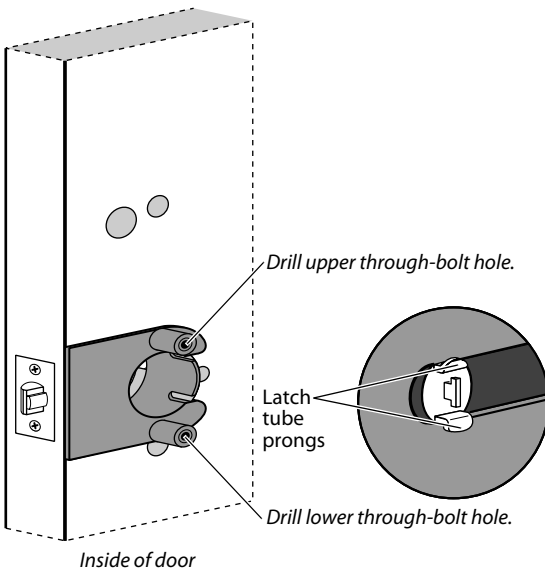

Figure 5 Installing the drill jig and drilling the through-bolt holes

## Preparing the door and door jamb

### 6 Install strike box and strike plate

- 1 In alignment with the center of the latchbolt, mortise the door jamb to fit the strike box and strike plate.
- 2 Drill the holes for the screws used to install the strike box and strike plate.
- 3 Insert the strike box and secure the strike with the two screws provided.
- 4 Check the position of the deadlocking plunger against the strike plate.

**Caution:** The deadlocking plunger of the latchbolt must make contact with the strike plate, as shown in Figure 6. The plunger deadlocks the latchbolt and helps prevent someone from forcing the latch open when the door is closed.

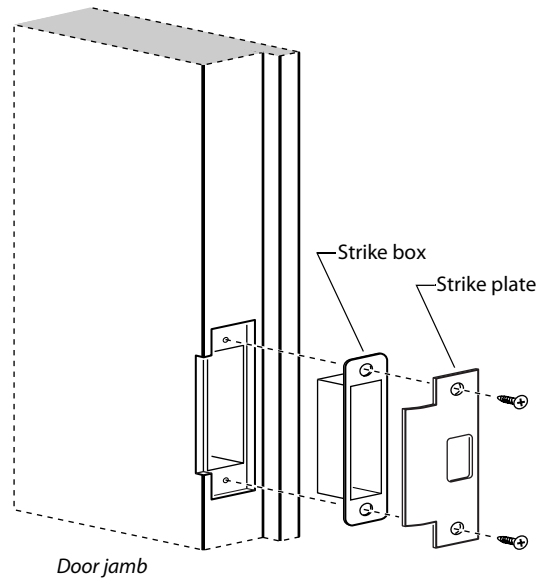

Figure 6a Installing the strike box and strike plate

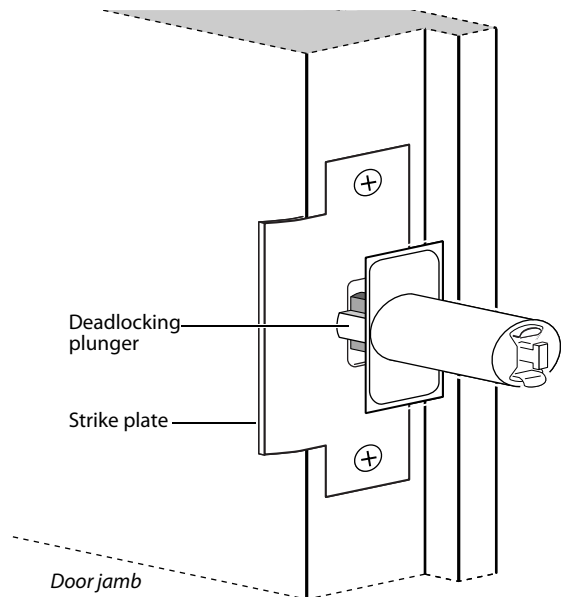

Figure 6 Aligning the deadlocking plunger with the strike plate

## Installing the lock

### 7 Remove outside lever or knob

- 1 Insert the control key into the core and rotate the key 15 degrees to the right.
- 2 Insert a flat blade screwdriver into the figure-8 core hole and into the lever.
- 3 Press the screwdriver blade in the direction of the arrow in Figure 7.

**Note:** You cannot remove the lever if the screwdriver blade is inserted too far past the keeper.

- 4 Slide the lever or knob off of the sleeve.

**Caution:** Be careful that you do not disconnect the lever keeper spring.

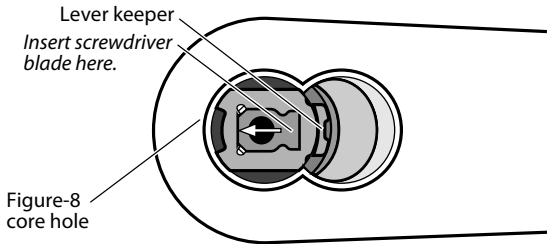

Figure 7 Removing the outside lever (9K shown)

### 8 Adjust for door thickness

- 1 Determine the door's thickness.
- 2 Pull the rose locking pin and rotate the outside rose liner until the proper groove on the through-bolt stud lines up with the hub face.

**83KG, 83KBV, 83KN or 83KZ only:**

- Using the door as a reference, center the retractor in the door.

**Note 1:** Make sure that the locking pin fully locks into the rose liner.

**Note 2:** The lockset fits doors 1 3/4" to 2 1/4" thick.

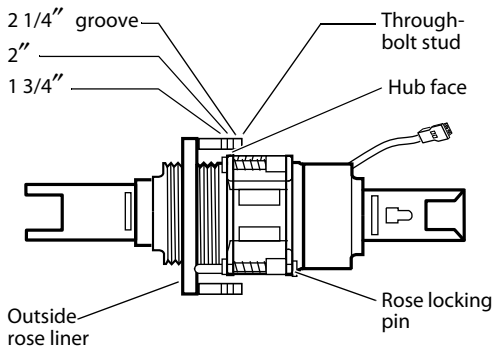

Figure 8 Adjusting the rose liner for the door thickness (9KG, 9KBV, 9KN and 9KZ shown)

## Installing the lock

### 9 Install lock chassis and engage retractor in latch

From the outside of the door, insert the lock chassis into the 2 1/8" chassis hole, routing the motor wire through the notch.

**Caution:** Make sure that the latch tube prongs engage the chassis frame and that the latch tailpiece engages the retractor.

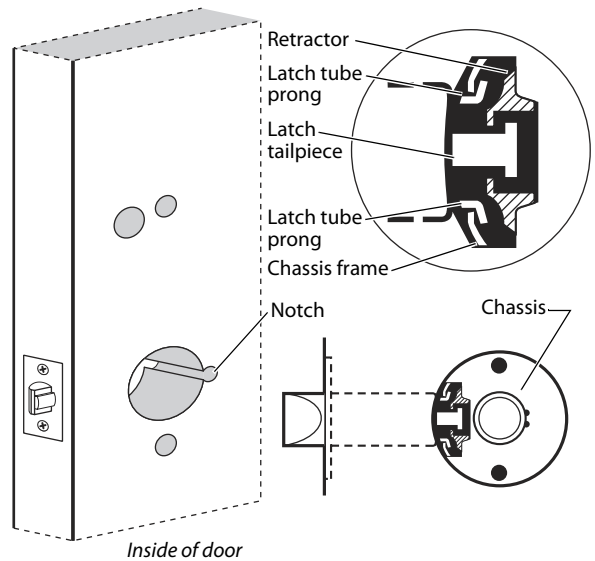

Figure 9 Installing the lock chassis and engaging the retractor in the latch (9K shown)

### 10 Optional: Offline G/V Series Locks only: Remove backup battery tab

**Caution 1:** For the lock to operate properly, you must remove the backup battery tab.

**Caution 2:** Do not connect the battery pack before you have removed the backup battery tab. Doing so may cause the lock to malfunction.

- 1 Locate the backup battery tab on the inside of the outside escutcheon.
- 2 Pull down on the tab and remove it from the outside escutcheon to turn on the backup battery.

## Installing the lock

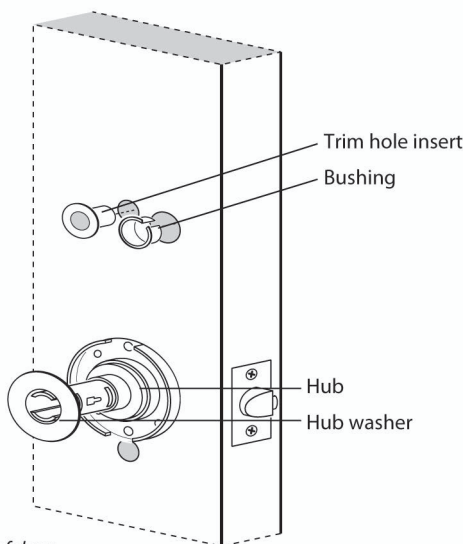

Outside of door

Figure 11 Installing the outside trim hole insert, bushing, and hub washer

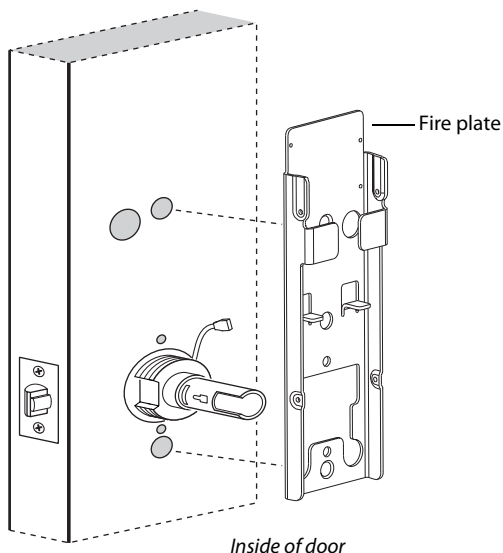

Inside of door

Figure 12 Installing the fire plate

### 11 Install the trim hole insert, bushing, and hub washer on outside of door

- 1 On the outside of the door, insert the trim hole insert into the upper trim hole, as shown in Figure 11.
- 2 Insert the bushing into the harness hole.
- 3 Slide a hub washer over the chassis sleeve so it rests on the hub.

### 12 Install fire plate

Position the fire plate on the inside of the door so that the chassis fits through the square opening in the fire plate, as shown in Figure 12.



## Installing the lock

### 13 Install through-bolts and inside rose liner

- 1 Place the inside rose liner on the chassis, aligning the holes in the rose liner with the holes prepared in the door, as shown in Figure 13.

**Caution:** Make sure that the motor wire is pulled toward the top of the fire plate and avoid routing it over any surface that could damage the sleeving or wire insulation.

- 2 Install the through-bolts through the rose liner and door in the top and bottom holes.

**Caution:** Make sure that there is clearance for the motor wire between the rose liner and the door.

- 3 Tighten the rose liner to the door and fire plate with the through-bolts.
- 4 Install the hub washer over the rose liner.

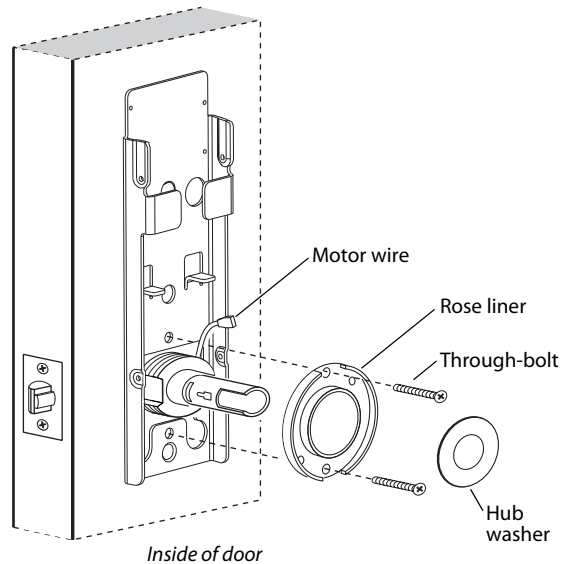

Figure 13 Installing the through-bolts and rose liner (9K shown)

### 14 Route wire harness and position outside escutcheon

- 1 From the outside of the door, feed the motor connector, battery connector, and Keypad EZ remote unlock wires through the harness hole one at a time, as shown in Figure 14.

**Caution:** When routing the connectors, make sure the wire harness is not routed across any sharp edges or over any surface that could damage its sleeving or wire insulation.

- 2 On the inside of the door, insert the two counter sunk mounting screws into the holes at the top and bottom of the fire plate.
- 3 Tighten the mounting screws until the fire plate is securely mounted to the door.

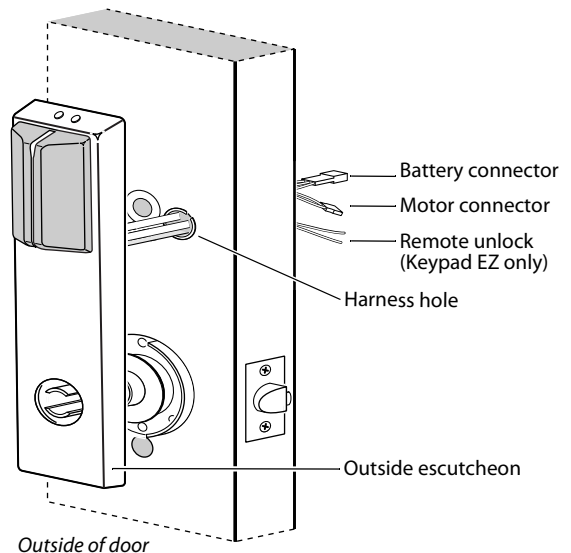

Figure 14 Feeding the wire harness connectors through the harness hole (Offline G/V Series Lock shown)

## Installing the lock

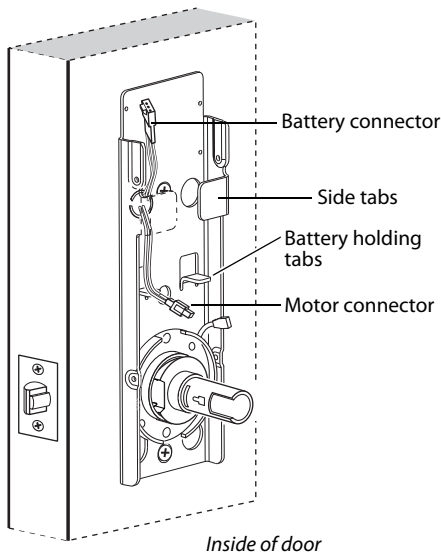

Figure 15 Routing the wires on the fire plate

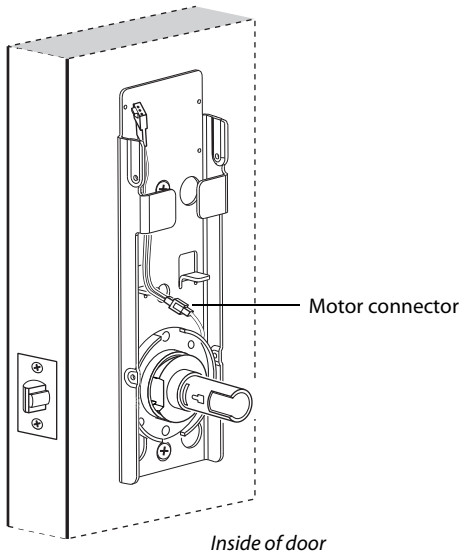

Figure 16 Making the motor connection

### 15 Route wires on fire plate

- 1 Route the motor connector wires underneath the side tabs, as shown in Figure 15.
- 2 **Optional: Keypad EZ Only:** Route the Keypad EZ wires underneath the side tabs.
- 3 Route the battery connector wire above the side tabs.

### 16 Make motor connection

- 1 From the inside of the door, connect the motor connector from the chassis to its mating connector on the wire harness, as shown in Figure 16.

**Note:** The motor connection has 2 wires and 2 pins. The wire colors are yellow and gray.

**Caution: When making the motor connection, make sure:**

- there are no loose wire connections where the wires are inserted into the connectors
  - the connectors are firmly mated.
- 2 **Optional: Keypad EZ Only:** Make the remote unlock connections with wire nuts or crimp connectors. See the *Installation Instructions for Keypad EZ Remote Unlock (T80922)* for more information.

## Installing the lock

### 17 Install bottom cover (inside escutcheon)

- 1 Making sure that the cover does not pinch the wires, guide the bottom cover over the chassis onto the fire plate.
- 2 Use two cover screws to secure the cover to the side of the fire plate, as shown in Figure 17.

**Note:** Phillips Type 2 and T20 Torx options are available for the cover mounting screws.

**Caution:** Dress all wires away from possible pinch points before bottom cover is put in place.

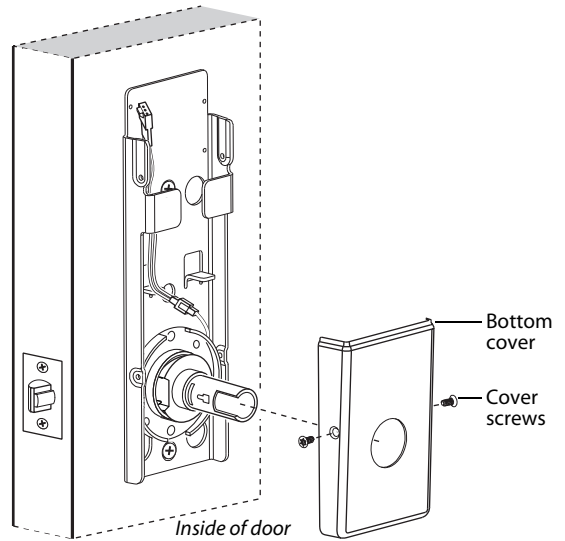

Figure 17 Installing the bottom cover

### 18 Install battery holder

- 1 Position the battery wires against the fire plate side wall, as shown in Figure 18.
- 2 Slide the battery pack behind the fire plate side tabs until it rests on the bent battery holding tabs.

**Caution:** When routing the battery wires, make sure the wires are not routed across any sharp edges or over any surface that could damage their sleeving or wire insulation.

- 3 Connect the battery pack to the battery connector on the wire harness.

**Caution:** When connecting the battery pack, make sure:

- ◆ there are no loose wire connections where the wires are inserted into the connectors.
- ◆ the connectors are firmly mated.

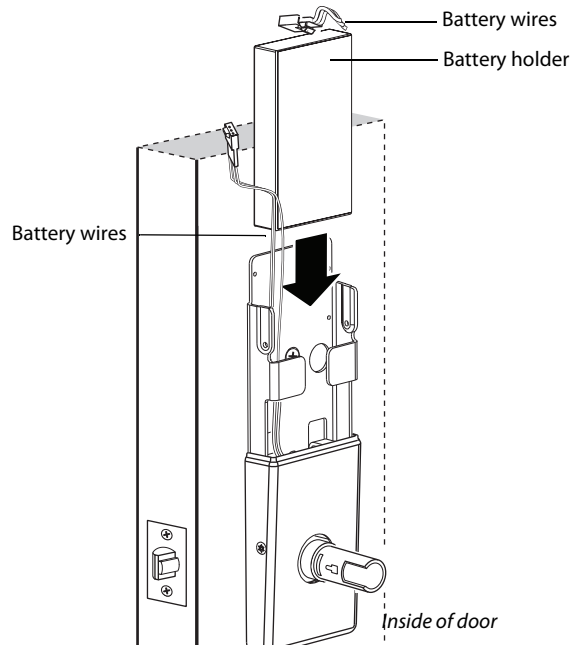

Figure 18 Installing the battery holder, 8-cell shown

## Completing the installation

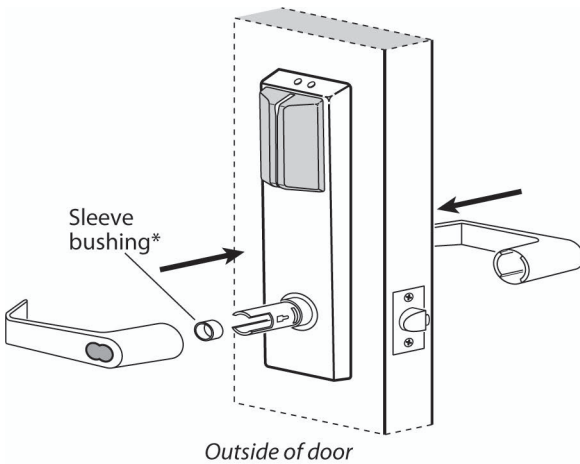

Figure 19 Installing the levers (9K shown)

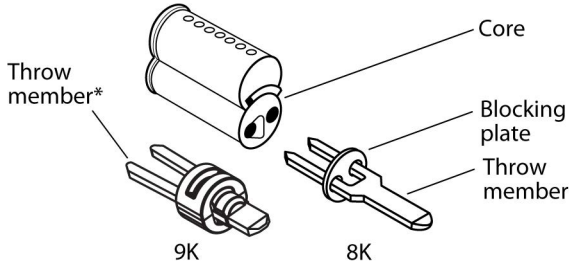

Figure 20a Installing the blocking plate and throw member

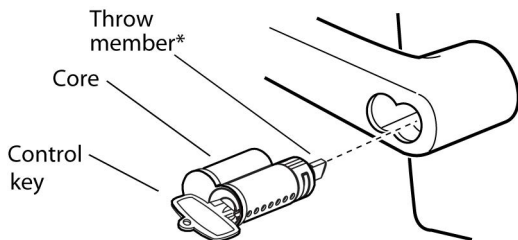

Figure 20b Installing the core

\*Patent Pending

### 19 Install inside and outside knobs/levers

**Note:** To use a core and throw member from a manufacturer other than BEST with a Electronic Stand-Alone Lock, see the Installation Instructions for 9K Non-interchangeable Cores & Throw Members (T56093). Skip task 20.

- 1 Insert the sleeve bushing into the outside sleeve.  
**Note:** Sleeve bushing is only required for the 9K lockset.
- 2 **For the inside and outside knobs.**  
Push firmly on the knob until it is seated.  
**For the inside and outside levers.**  
With the handle pointing toward the door hinges, position a lever on the outside sleeve and push firmly on the lever until it is seated. Repeat, placing the other lever on the inside sleeve.
- 3 Tighten the escutcheon mounting screws.
- 4 Turn the knobs/levers to check that they operate smoothly.

### 20 Install core and throw member

- 1 Install the throw member into the back of the core.
- 2 Insert the control key into the core and rotate the key 15 degrees to the right.

**Caution:** You must use the blocking plate when installing an 8K lockset to prevent unauthorized access.

**For 6-pin core users only:** Install the plastic spacer (not shown, supplied with permanent cores).

- 3 Insert the core and throw member into the lever with the control key.
- 4 Rotate the control key 15 degrees to the left and withdraw the key.

**Caution:** The control key can be used to remove cores and to access doors. Provide adequate security for the control key.

## Completing the installation

### 21 Install top cover (inside escutcheon)

- 1 Position the top cover above the fire plate and slide it down over the guide notches on the fire plate.

**Caution:** Make sure that the top cover does not pinch any wires as you slide it over the fire plate.

- 2 Use two cover screws to secure the cover to the side of the fire plate, as shown in Figure 21.

**Note:** Phillips Type 2 and T20 Torx options are available for the cover mounting screws.

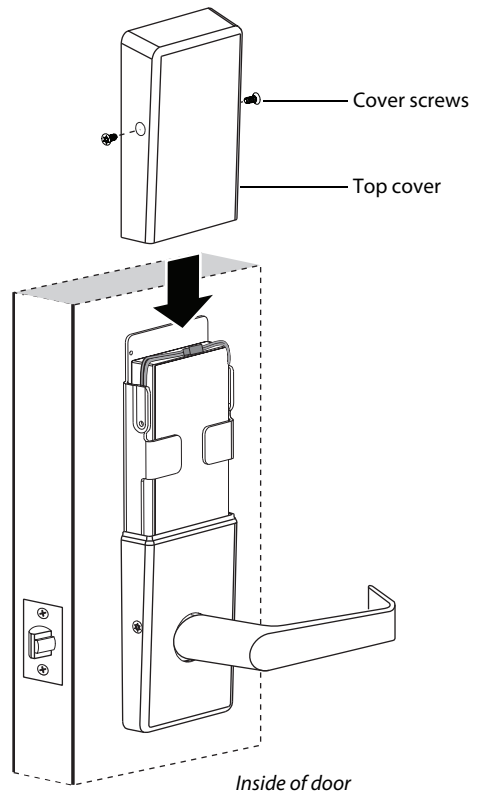

Figure 21 Installing the top cover

## Completing the installation

### 22 Test lock

#### For Keypad EZ Locks only:

To test the lock for proper operation before the lock is programmed, follow these instructions:

- 1 Press **9998**.
- 2 Press **#**.  
*The green light flashes and the locking mechanism unlocks.*
- 3 Turn the lever and open the door.

#### For Offline G/V Series Locks only:

Offline G/V Series locks, by default, are set to run in cylindrical mode. A temporary operator card is provided for testing the lock and it will be deleted after programming.

- 1 Use the temporary operator card to test the lock.  
*The green light flashes and the unit locks and relocks after three seconds.*
- 2 Check the handle to make sure the lock unlocks and then relocks.

If the mechanism doesn't unlock, refer to the following table. For additional troubleshooting instructions, see the *Electronic Stand-Alone Locks Service Manual*.

LEDs	Sounder	You should
Single red flash	—	Use the card at a moderate speed.
Red flashes	3 short tones	Use the temporary operator card provided with the lock.
Green flashes	—	Check the motor connection.
—	—	Check the battery connection.





For assistance or warranty information:  
Call 1-800-392-5209 or visit  
<https://dhwsupport.dormakaba.com/hc/en-us>

**Warning:** This Manufacturer advises that no lock can provide complete security by itself. This lock may be defeated by force or technical means, or evaded by entry elsewhere on the property. No lock can substitute for caution, awareness of your environment, and common sense. Builder's hardware is available in multiple performance grades to suit the application. In order to enhance security and reduce risk, you should consult a qualified locksmith or other security professional.



Si desea ayuda o información sobre la garantía:  
llame al 1-800-392-5209 o visite  
<https://dhwsupport.dormakaba.com/hc/en-us>

**Advertencia:** Este fabricante hace saber que no hay cerraduras que puedan proporcionar seguridad completa por sí mismas. Esta cerradura puede fallar forzándola o utilizando medios técnicos o entrando por otra parte del edificio. No hay cerraduras que puedan sustituir precaución, estar al tanto de su entorno y sentido común. Este fabricante también ofrece cerraduras de diferentes grados y rendimientos para ajustarse a su aplicación. Para mejorar la seguridad y reducir riesgos, usted debe consultar con un cerrajero especializado u otro profesional de seguridad.



Pour de l'aide ou des informations sur la garantie:  
Veuillez appeler le 1-800-392-5209 ou visiter  
<https://dhwsupport.dormakaba.com/hc/en-us>

**Advertissement:** Le fabricant tient à vous aviser qu'aucun verrou ne peut à lui seul offrir une sécurité complète. Ce verrou peut être malhonnêtement forcé par la force ou des moyens techniques ou être évité par l'utilisation d'une autre entrée sur la propriété. Aucun verrou ne peut remplacer la surveillance de votre environnement et le bon sens. La qualification pour le constructeur est offerte selon différents grades de performance pour différentes applications. Afin d'améliorer la sécurité et de réduire le risque, vous devez consulter un serrurier qualifié ou un autre professionnel de la sécurité.