

Installation Instructions

Fail Secure BES-4105U / BES-4108U & Fail Safe BES-4306U / BES-4309U



Spanish and French translations are available on <https://dhwsupport.dormakaba.com/hc/en-us>
 Traducciones al español y francés están disponibles en <https://dhwsupport.dormakaba.com/hc/en-us>
 Des traductions en espagnol et en français sont disponibles sur <https://dhwsupport.dormakaba.com/hc/en-us>

- Determine the vertical centerline of the door lock face and the horizontal centerline of the latch.
IMPORTANT: When determining the horizontal centerline observe the following:
FOR MORTISE LOCKS: Align the angled ramps of the lip bracket with the deadlock trigger of the mortise latch.
FOR CYLINDRICAL LOCKS: Align the center of the latch with the center of the strike opening.**
- Transfer both the horizontal and vertical centerlines to the doorframe.**
- Prepare the doorframe for cutting as per the appropriate drawing.
- If required, install "no weld" mounting brackets as per the instructions on page 3.
- Attach the strike insert (coil unit or "motor") to the lip bracket with the small machine screws provided. (M4 x 9.5mm)
- Attach the strike faceplate to the lip bracket with machine screws (M4 x 9.5mm) provided. (It may be desirable to leave these screws slightly loose to facilitate insertion into the doorframe.)
- Connect the incoming wiring from the power supply to the terminal screws on the strike insert. BEST door strikes are not polarity sensitive although be certain to observe proper polarity if a suppression diode is required for access control applications.
- Install the door strike in the doorframe using the screws provided.

B404-BES Aluminum Frames, 1-1/2" D

MEASUREMENT	FRACTIONAL INCHES	DECIMAL INCHES	METRIC mm
A	1-1/4"	1.250	31.75
B	4-7/8"	4.875	123.83
C	3-3/8"	3.375	85.73
D	7/8"	.875	22.23
E	3/8"	.375	9.53
F	1/8"*	.125*	3.18*
G	1-11/16"	1.688	42.86
X	Vertical Centerline of Door**		
R	5/32"	.156	3.97
K	4-1/8"	4.125	104.78
M	12-24"	—	—

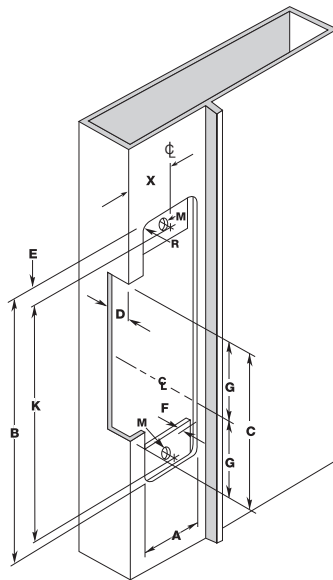

B414-BES Hollow Metal Frames, 1-1/2" D

MEASUREMENT	FRACTIONAL INCHES	DECIMAL INCHES	METRIC mm
A	1-1/4"	1.250	31.75
B	4-7/8"	4.875	123.83
C	3-3/8"	3.375	85.73
D	7/8"	.875	22.23
E	3/8"	.375	9.53
F	1/8"*	.125*	3.18*
G	1-11/16"	1.687	42.86
X	Vertical Centerline of Door**		
K	4-1/8"	4.125	104.78
M	12-24"	—	—

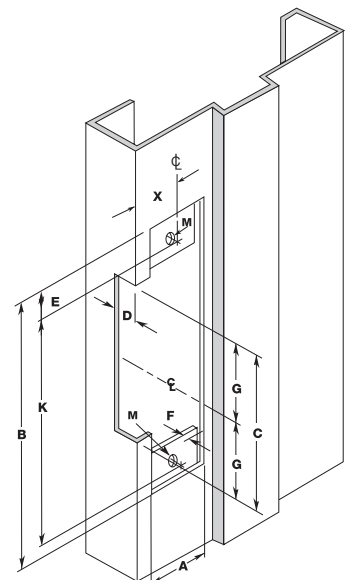

NOTE: Specifications subject to change without notice.

* Dimension F is measured from face of mounting tab to face of frame.

** Dimension X on the drawing is determined by the vertical centerline of the door. If the latch incorporates a deadlocking pin additional steps will be necessary to ensure proper operation of the deadlocking pin. Measure the thickness of the deadlocking pin and add this thickness to Dimension X to relocate the vertical centerline an appropriate distance on the frame.

† For wood frame door installations, substitute #12 wood screws for dimension M.

B408-BES Aluminum & Wood Frames, 1-1/2" D

MEASUREMENT	FRACTIONAL INCHES	DECIMAL INCHES	METRIC mm
A	1-7/16"	1.438	36.51
B	7-15/16"	7.938	201.61
C	3-3/8"	3.375	85.73
D	7/8"	.875	22.23
E	1/4"	.250	6.35
F	1/8"*	.125*	3.18*
G	1-11/16"	1.687	42.86
X	Vertical Centerline of Door**		
R	5/32"	.156	3.97
K	7-7/16"	7.438	188.91
M	12-24" [†]	—	—

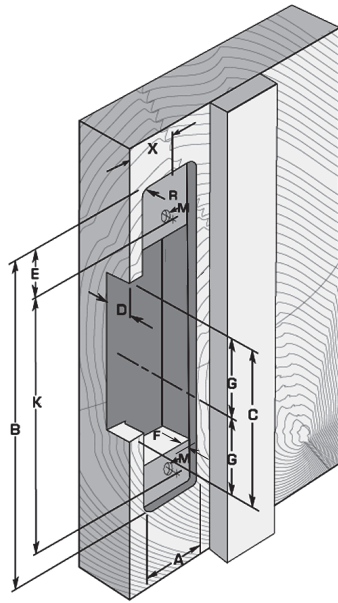

B407-BES Aluminum Frames, 1-1/2" D

MEASUREMENT	FRACTIONAL INCHES	DECIMAL INCHES	METRIC mm
A	1-1/4"	1.250	31.75
B	6-7/8"	6.875	174.64
C	3-3/8"	3.375	85.73
D	7/8"	.875	22.23
E	3/8"	.375	9.53
F	1/8"*	.125*	3.18*
G	1-11/16"	1.687	42.86
X	Vertical Centerline of Door**		
R	5/32"	.156	3.97
K	6-1/8"	6.125	155.58
M	12-24"	—	—

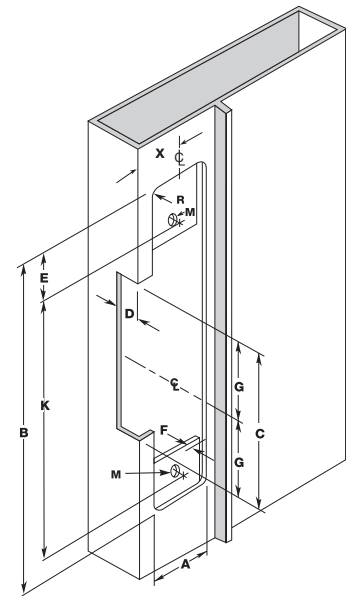

NOTE: Specifications subject to change without notice.

* Dimension F is measured from face of mounting tab to face of frame.

** Dimension X on the drawing is determined by the vertical centerline of the door. If the latch incorporates a deadlocking pin additional steps will be necessary to ensure proper operation of the deadlocking pin. Measure the thickness of the deadlocking pin and add this thickness to Dimension X to relocate the vertical centerline an appropriate distance on the frame.

[†] For wood frame door installations, substitute #12 wood screws for dimension M.

When installing an electric strike on an inactive door of a set of double doors, it can be treated the same as a frame installation in most situations. For more information contact the Technical Service Department.

Mounting Tab Kit Instructions

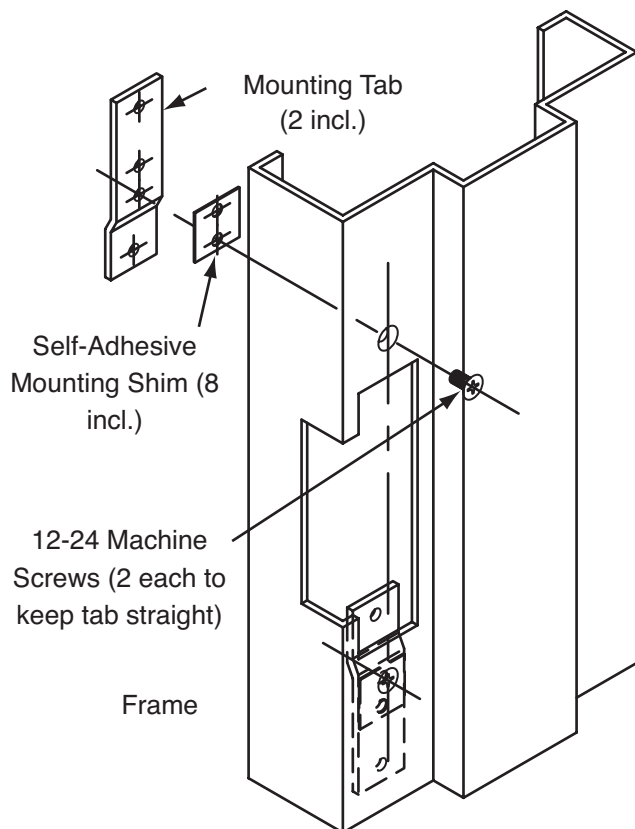

The mounting tab kit is for use with aluminum and steel frames that do not have factory installed mounting tabs for electric strike installation.

1. Prepare the frame as shown in the approximate drawing. Fasten the mounting tab to the faceplate of the strike, selecting the appropriate shims for the installation.
2. Using the assembled strike and tabs as a template, place against the frame and mark the mounting hole locations that suit best. Remove and drill two 3/16" holes in frame for each mounting tab and countersink the frame.
3. Remove the tabs from the faceplate and install in the frame using the 12-24 x 3/8" machine screws supplied. Tabs are zinc plated and drilled and tapped for this purpose.
4. Make final electrical connections per wiring instructions and mount strike to the tabs with the 12-24 x 3/8" machine screws.

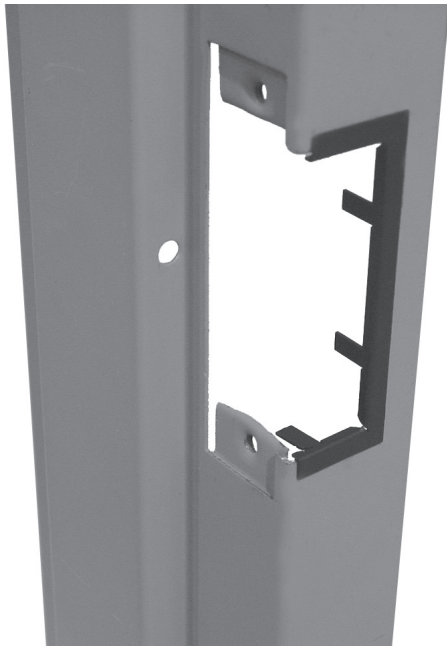

Trim Plate Instructions

1. Position the Trim Plate on the frame cut-out to verify fit and coverage.
2. Adjust cut-out if required.
3. Bend the four tabs to hold the Trim Plate onto the frame.
4. For a tighter fit, pre-bend the two long flange tabs before sliding onto the frame where space allows.
5. Secure the strike to the frame as per strike installation instructions.

Troubleshooting Guide

Problem	Possible Causes	Solution
1. Strike will not lock or unlock properly	No power to the strike	Using a multimeter, confirm that you have the correct output voltage at the power supply. Using a multimeter, confirm that you have the correct input voltage at the strike. Confirm that all connections are tight and secure.
	Incorrect voltage used	Confirm that the insert and power supply are the proper voltage.
	Strike is binding	Confirm that the strike keeper functions when the door is open. If the strike operates correctly, adjust door or strike to eliminate any backpressure. Confirm that the strike cavity depth is compatible with the lock set.
2. Strike releases but won't buzz	Improper power supply	Replace the power supply with a correct voltage AC power supply. If this cannot be done, a DC piezo buzzer can be installed.
3. Strike makes a buzzing sound	Improper power supply Improper application	Replace the power supply with a correct voltage DC power supply. A strike connected to an AC power supply will buzz unless a rectifier is installed.
4. Strike has a burnt smell	Improper voltage Improper installation	Confirm that you have the correct output voltage at the power supply. Confirm that all connections are tight and secure.
5. Mortise lock not dead latching	Improper installation Door has sagged	Check alignment of dead latch and lip bracket ramp. Adjust door alignment.
6. Cylindrical dead latching not working	Improper installation / Door has warped	Adjust the strike horizontal adjustment. (See Installation Instructions).
7. Door won't latch	Door has warped or sagged creating excessive back pressure	Re-align door in frame or replace.