

Installation Instructions for Double Acting Horizontal Spring Pivot Model BB159

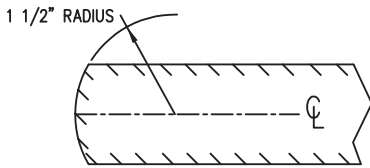

dormakaba Group

STEP (1)



ROUND OFF EDGE OF DOOR AT PIVOT SIDE TO ALLOW FOR CLEARANCE.

STEP (2)

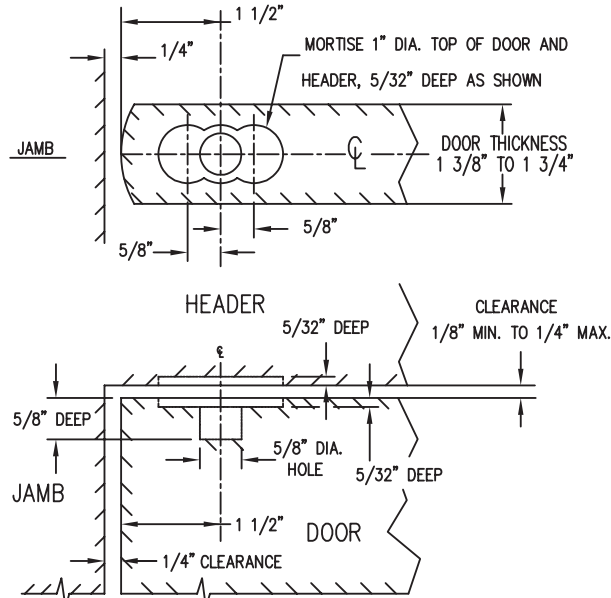

PREPARE 1" DIAMETER CUT OUT IN THE TOP OF THE DOOR AND HEADER.

INSTALL THE TOP PIVOT INTO THE HEADER AND MOUNT THE TOP PIVOT PLATE INTO THE TOP OF THE DOOR.

BOTH THE TOP PIVOT ASSEMBLY AND THE SPRING PIVOT IN THE BOTTOM OF THE DOOR MUST BE PLUMB AND ON THE SAME CENTERLINE.

STEP (3)

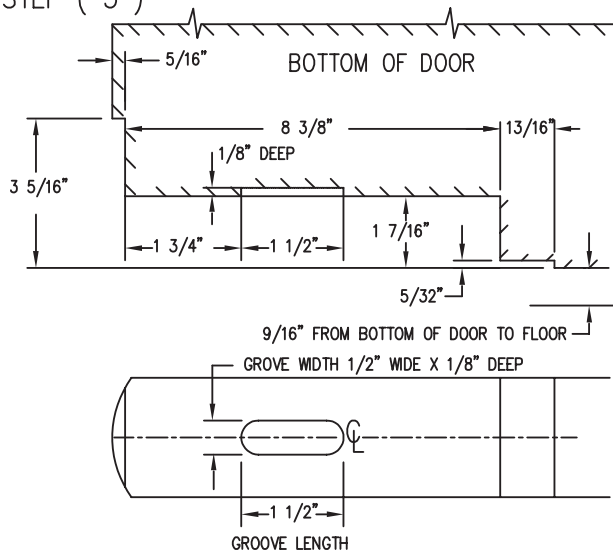

PREPARE THE BOTTOM CORNER OF DOOR.

STEP (4)

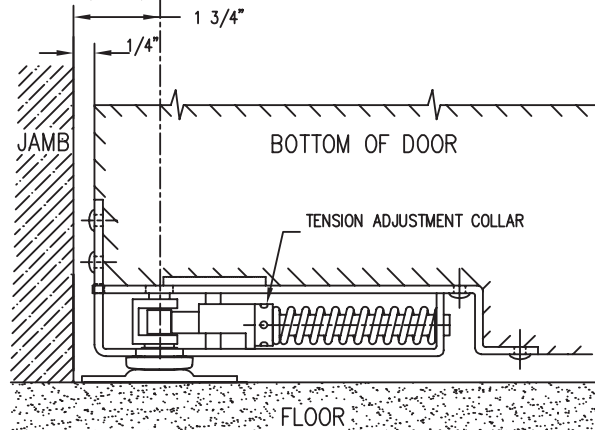

INSTALL THE SPRING PIVOT ASSEMBLY AS SHOWN.

STEP (5)

INSERT THE TOP PIVOT INTO THE TOP PIVOT PLATE.

SWING THE DOOR INTO PLACE AS SHOWN.

FASTEN THE FLOOR PLATE SECURELY TO THE FLOOR.

ADJUST SPRING TENSION BY TURNING TENSION COLLAR.

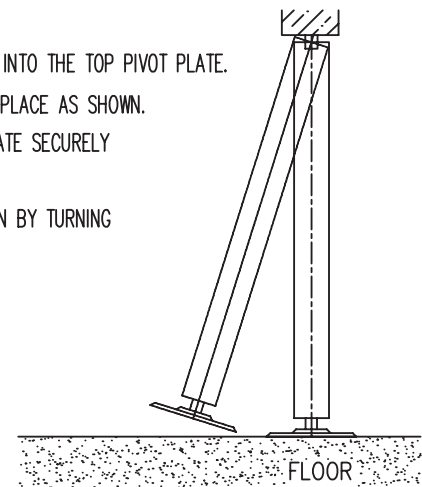

STEP (6)

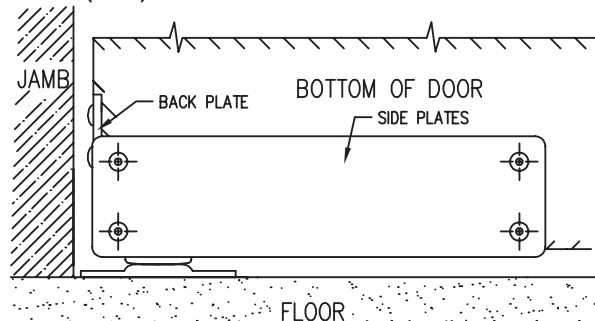

INSTALL SIDE PLATES AS SHOWN. (USE TOP HOLES IN SIDE PLATES ONLY)

ATTACH BACK PLATE USING SELF TAPPING MACHINE SCREW.