

Installation Instructions for Field Application of 225R Shock Arrestor

- a. When used as specified for new installations, doors and frames should be prepared in accordance with Template #T90-34.
- b. If unit is being installed at an existing opening, damaged hinges and hinge reinforcements should be repaired or replaced and the door properly aligned with the frame before installing the shock arrestor. (See Publication #H1399 - Shimming Instructions).
- c. The 225R Shock Arrestor is designed to fit doors inset 1/8". If frame and door faces are flush, place a 1/8" thick shim underneath the frame plate only.

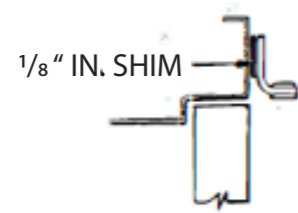

- d. The 225R Shock Arrestor is designed to align with hinges that are 4 1/2" wide.

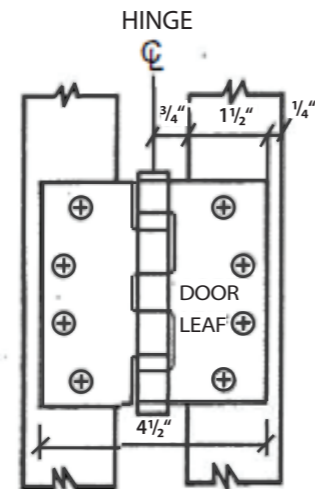

1. Determine hand of door. Either RH or LH.



2. Remove safety plugs from correct holes in frame plate and door plate.

REMOVE THIS PLUG AND INSERT BRONZE BUSHING HERE FOR RIGHT HAND DOORS

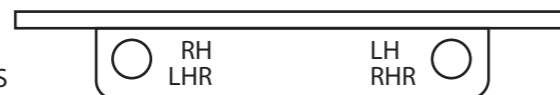

REMOVE THIS PLUG AND INSERT BRONZE BUSHING HERE FOR LEFT HAND DOORS

FRAME PLATE

REMOVE THIS PLUG AND SCREW IN PINTLE FOR RIGHT HAND DOORS



REMOVE THIS PLUG AND SCREW IN PINTLE FOR LEFT HAND DOORS

DOOR PLATE

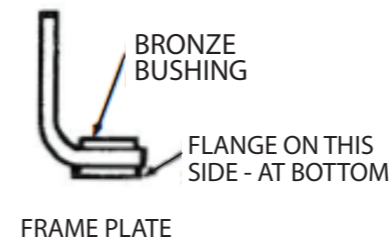

FRAME PLATE

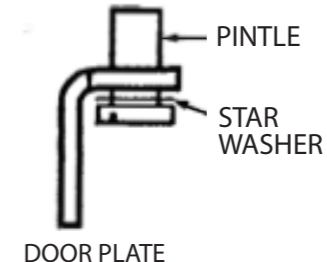

DOOR PLATE

3. Scribe vertical line 4 7/16" from hinge edge of door starting at top of door and extending down approximately 2"

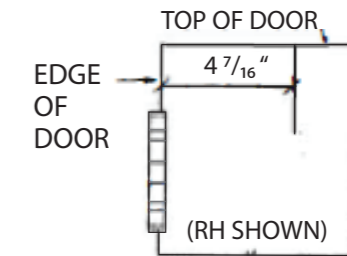

4. Position door plate at top corner of door aligning plate with top edge of door and line from Step 3. Mark hole locations by tracing through door plate onto pull face of door. Drill 3/8" diameter holes through door at four places. Insert through bolts and fasten door plate to door.

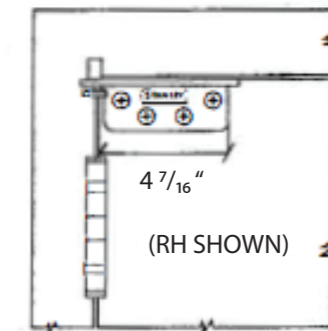

5. Place frame plate on top of door plate engaging Pintle into bushing. Align plate parallel and mark frame through holes in frame plate. Drill 7/16" diameter holes at five places in frame and install expandable anchor inserts using wrench provided. Fasten frame plate with 1/4 - 20 machine screws

