

FULL MORTISE TEMPLATE BUTT HINGES WITH SHEAR RESISTANT STUD

Size: 5 × 4½"

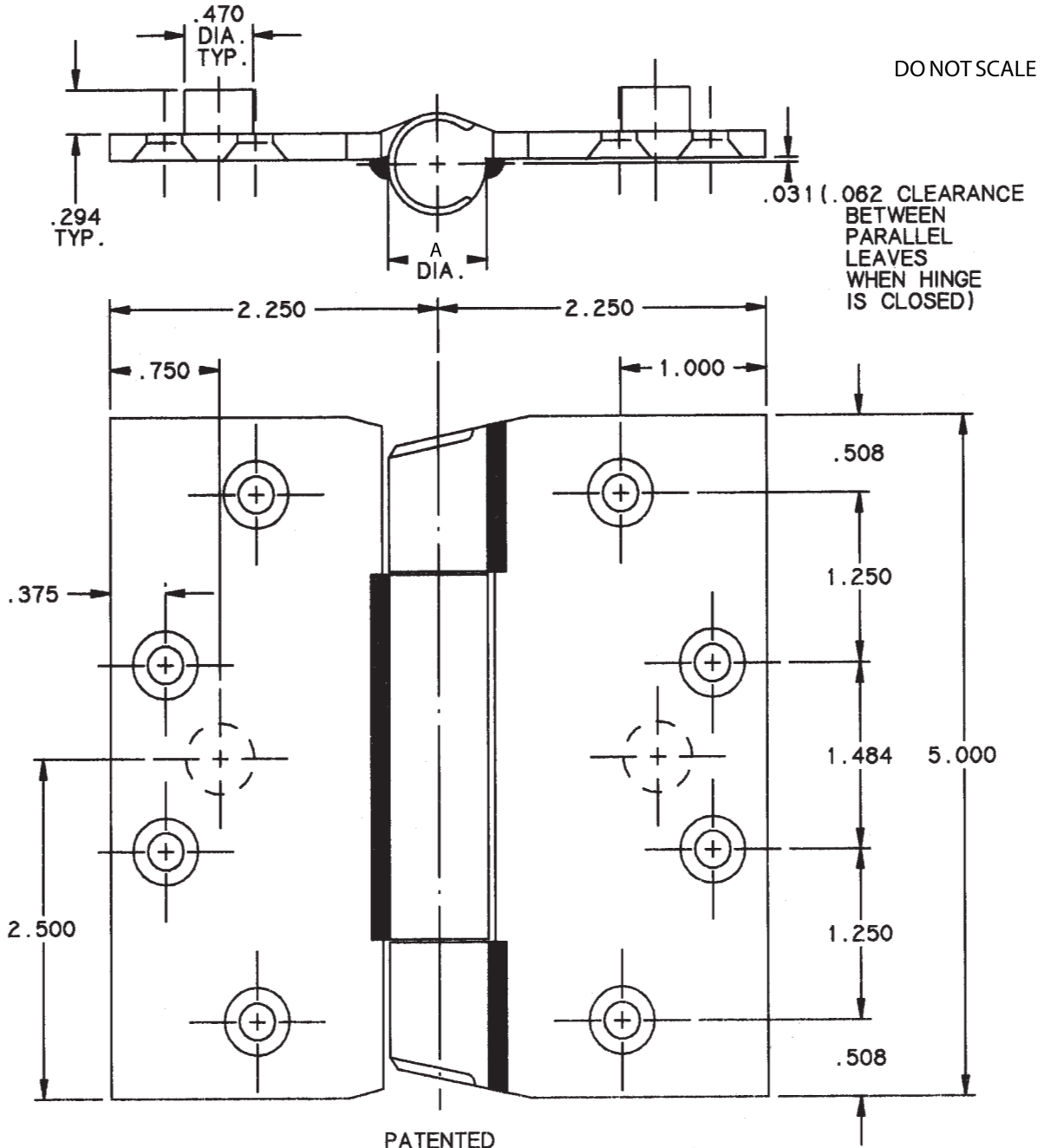

CLASS NUMBER		Gauge of Metal	A
Steel Hinges	Stainless Steel Hinges		
IHTCB1901 x SRS	IHTCB1961 x SRS	0.190	0.715
IHTCB1901R x SRS	IHTCB1961R x SRS	0.190	0.748
IHTCB168 x SRS	IHTCB199 x SRS	0.190	0.748

Machine Screw Size — 12-24 × ½ F.H.

This template conforms with ANSI standard A156.7.

