

**661HDWTLL - ALUMINUM GEARED HINGE, WIDE THROW, FLUSH MOUNT, FULL CONCEALED**

HINGES ARE SUPPLIED WITH LEAD-LINED MOUNTING HOLES FOR ADDITIONAL SUPPORT AS STANDARD

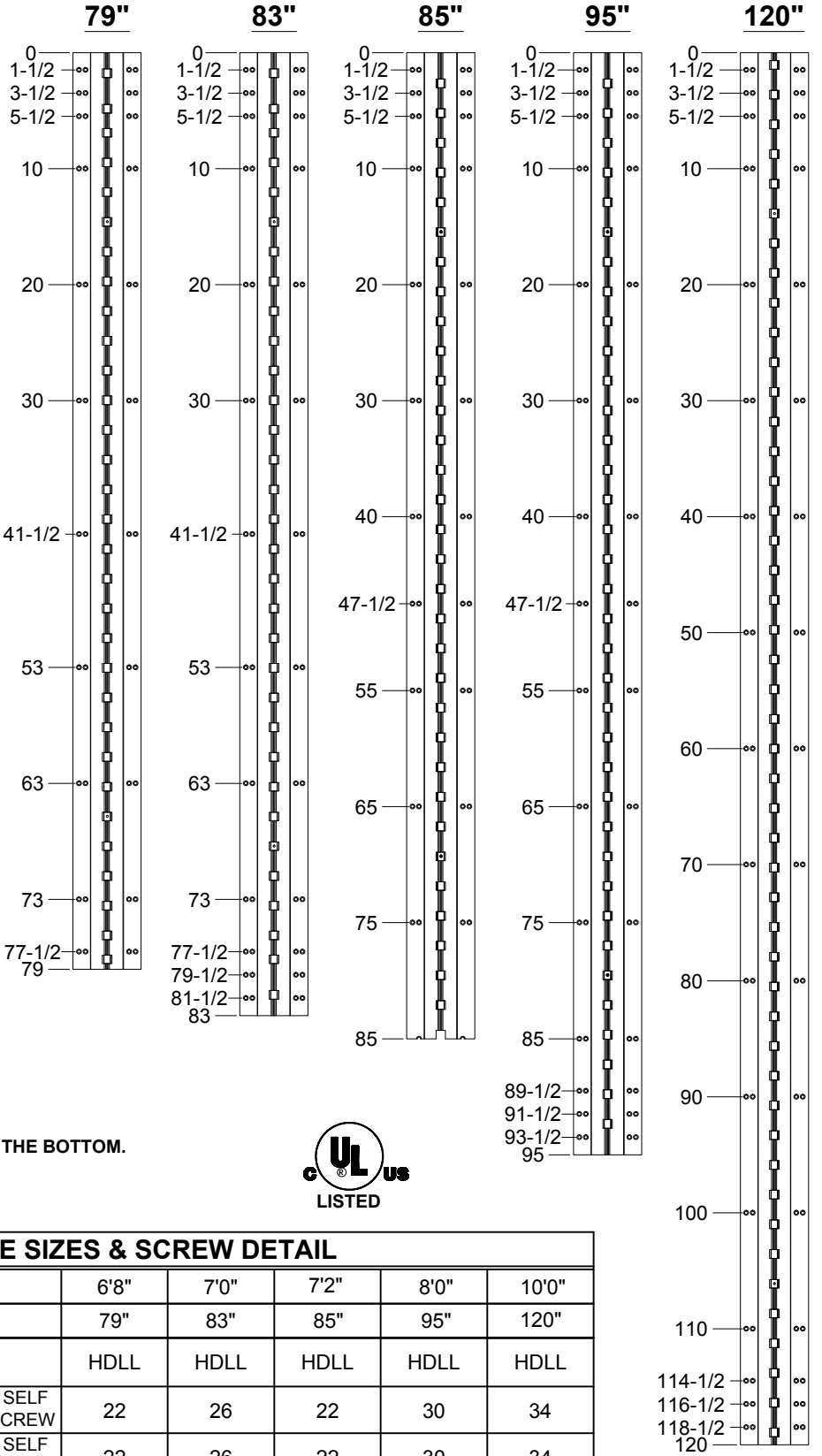

- NOTES:**
- HINGES CUT TO CUSTOM LENGTH ARE CUT FROM THE BOTTOM.
  - ALL DIMENSIONS ARE IN INCHES.
  - ALL DIMENSIONS ARE TO CENTERLINE OF HOLES.

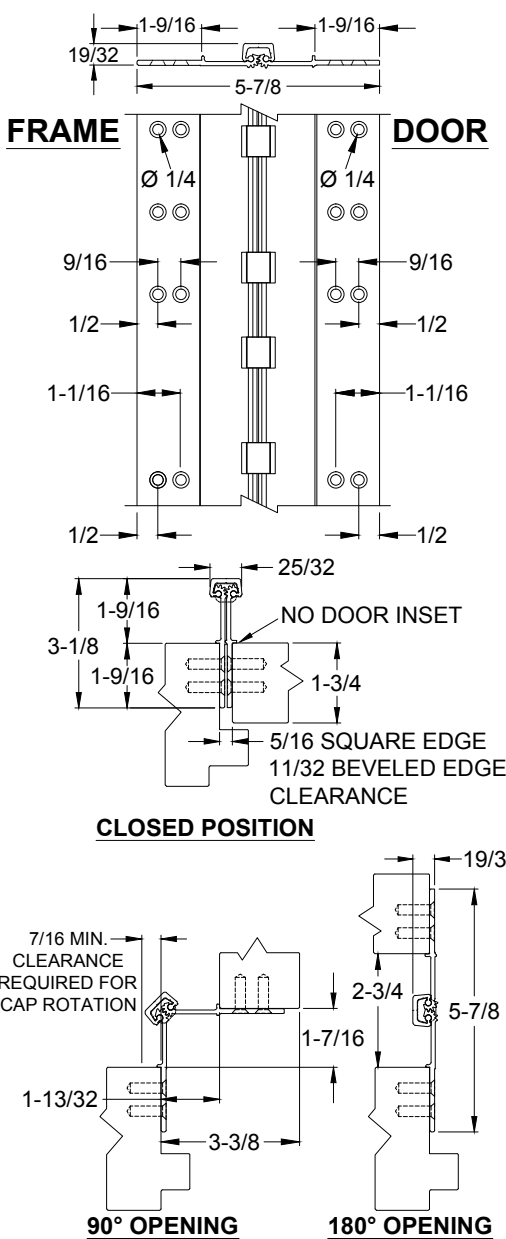

**STANDARD HINGE SIZES & SCREW DETAIL**

		6'8"	7'0"	7'2"	8'0"	10'0"
NOMINAL DOOR HEIGHT		6'8"	7'0"	7'2"	8'0"	10'0"
ACTUAL HINGE LENGTH		79"	83"	85"	95"	120"
MODEL: HDLL = HEAVY DUTY (HD) LEAD-LINED (LL)		HDLL	HDLL	HDLL	HDLL	HDLL
FRAME	12-24 x 7/8" PHILLIPS FLAT HEAD, UNDERCUT, SELF DRILLING, THREAD FORMING TEK MACHINE SCREW	22	26	22	30	34
DOOR	12-24 x 7/8" PHILLIPS FLAT HEAD, UNDERCUT, SELF DRILLING, THREAD FORMING TEK MACHINE SCREW	22	26	22	30	34

