

665HD - ALUMINUM GEARED HINGE, SWING CLEAR, NO INSET, FULL SURFACE

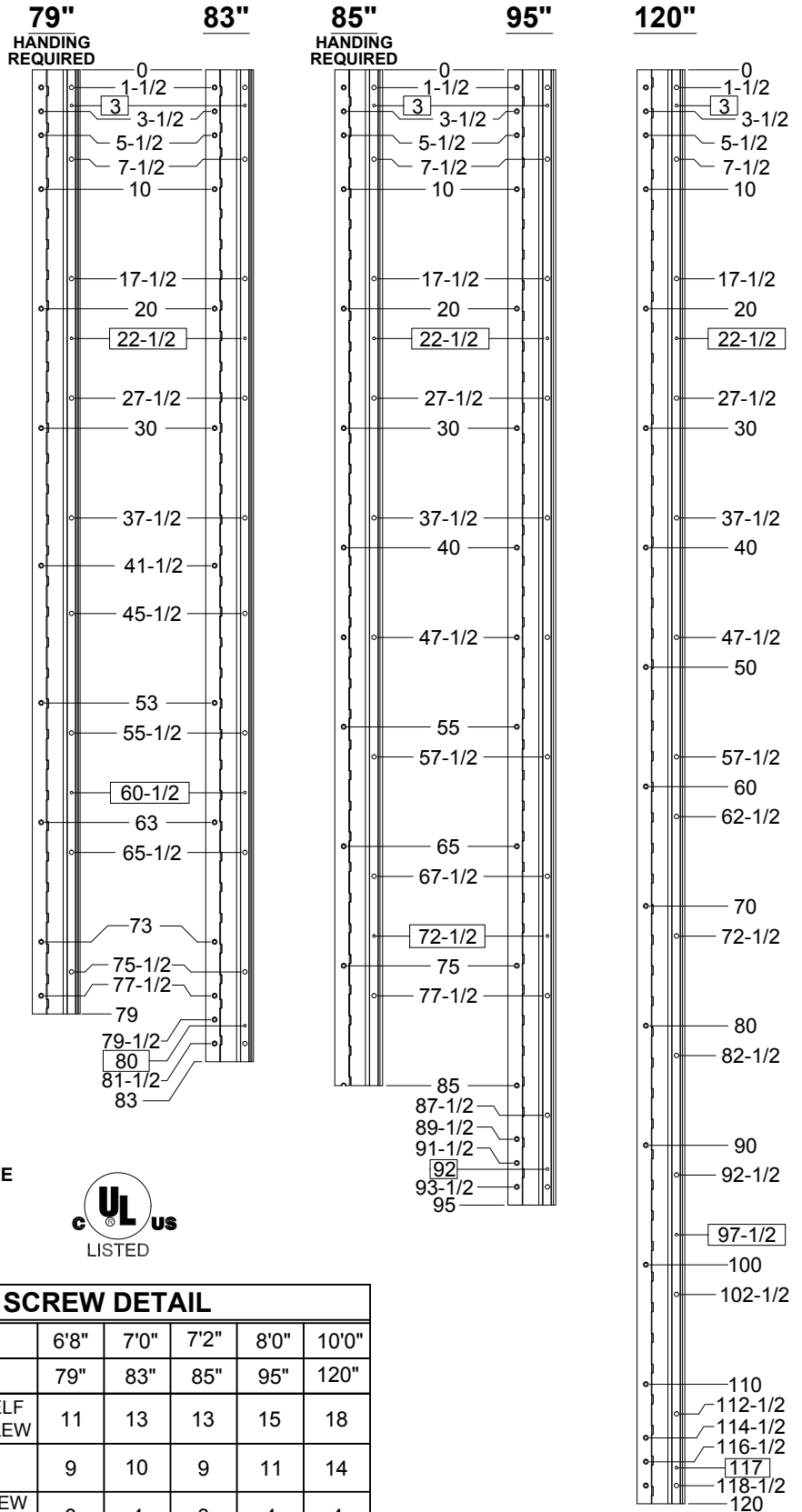

NOTES:

- HINGES CUT TO CUSTOM LENGTH ARE CUT FROM THE BOTTOM. PLEASE SPECIFY HANDING.
- ALL DIMENSIONS ARE IN INCHES.
- ALL DIMENSIONS ARE TO CENTERLINE OF HOLES.
- XX" DENOTES LOCATOR HOLE.

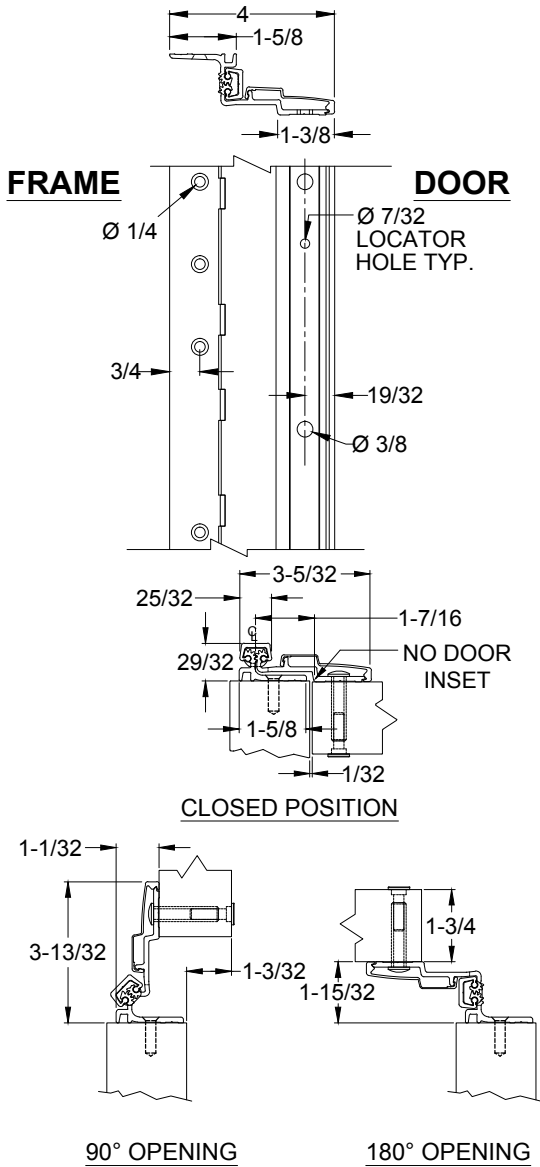

STANDARD HINGE SIZES & SCREW DETAIL

NOMINAL DOOR HEIGHT	6'8"	7'0"	7'2"	8'0"	10'0"
ACTUAL HINGE LENGTH	79"	83"	85"	95"	120"
FRAME	12-24 x 7/8" PHILLIPS FLAT HEAD, UNDERCUT, SELF DRILLING, THREAD FORMING TEK MACHINE SCREW				
DOOR	1/4-20 x 1-11/16" x 3/8 DIA. SEX BOLT & 1/4-20 x 1-1/8" PH. HEAD SHOULDER SCREW				
	12-24 x 7/8" PH. PN. HD. SELF DRILLING TEK SCREW (LOCATOR HOLE)				
	11	13	13	15	18
	9	10	9	11	14
	3	4	3	4	4

