

HALF SURFACE "SWING-CLEAR" TEMPLATE HINGES

Size: 5"

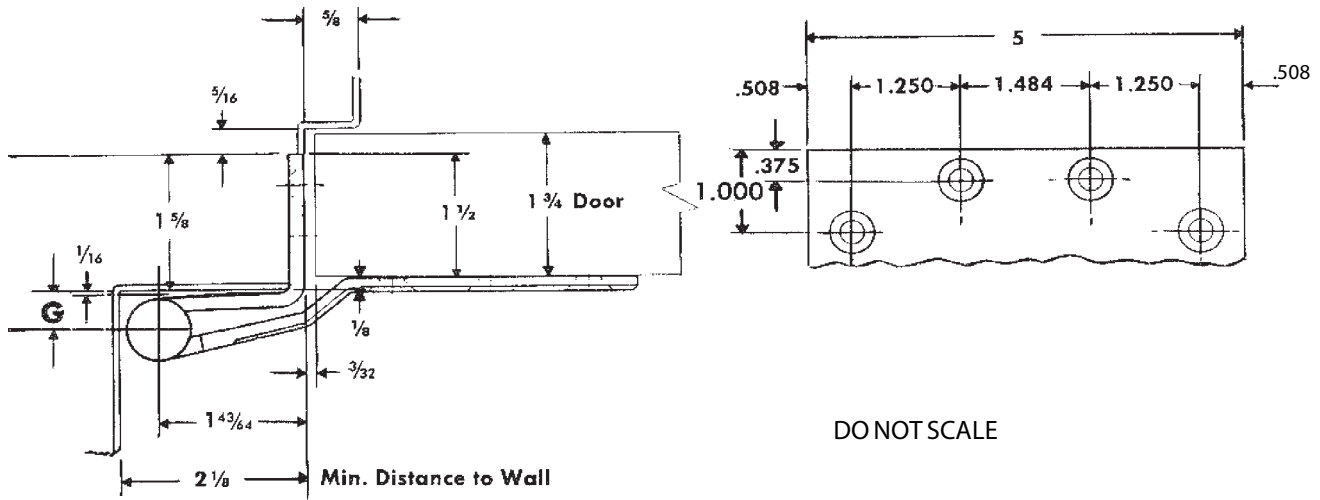

DO NOT SCALE

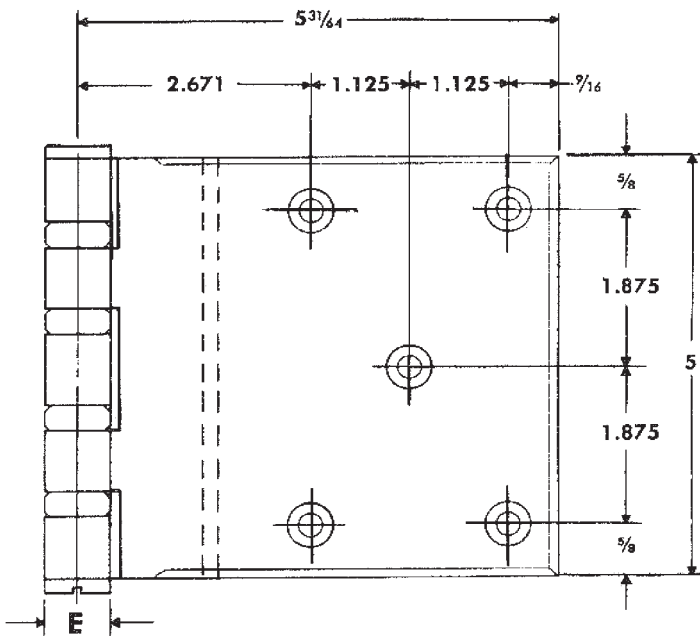

NOTES:

- 1 1 3/4 doors will clear opening at 95°.
- 2 This hinge alters the normal pivot point of door. For door closers, friction or overhead door holders to be used in conjunction with this hinge, consult manufacturer of the device to be used for application details.
- 3 For doors thicker than 1 3/4, backsets on doors and frames should be increased by the amount of the additional door thickness.

Class No.	Material	Gauge of Metal	(E) Outside Diameter	F	G
CB269	Steel	0.190	0.748	2 1/8	1/2
FBB269	Steel	0.190	0.748	2 1/8	1/2
CB1959	Steel	0.190	0.715	2 3/32	15/32
CB1959R	Steel	0.190	0.748	2 1/8	1/2

Template hinges of the hospital type conform to above screw hole location. Hospital type hinges are designated by prefix "HT" to class number.

Jamb Leaf — Machine Screw Size — 1/2 x 12-24 F.H.

Door Leaf — Screw Size — 2 x 1/4-20 O.H.M.S. with grommet nut or 1 1/2 x No. 14 O.H. wood screw.

