

FULL MORTISE "SWING-CLEAR" TEMPLATE BUTT HINGES

Size: 4½"

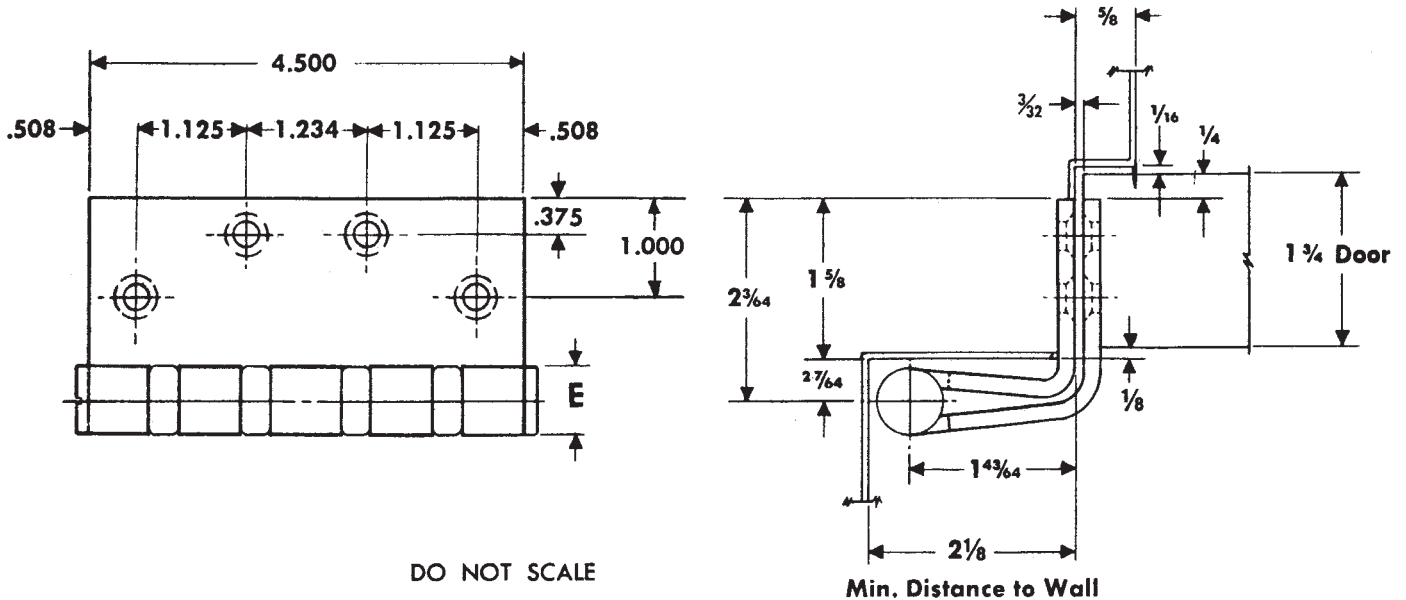

NOTES:

- 1 1¾ doors will clear opening at 90°.
- 2 This hinge alters the normal pivot point of door. For door closers, friction or overhead door holders to be used in conjunction with this hinge, consult manufacturer of the device to be used for application details.
- 3 For doors thicker than 1¾, backsets on doors and frames should be increased by the amount of the additional door thickness.

Class No.	Material	Gauge of Metal	(E) Outside Diameter
CB268	Steel	0.180	0.698
FBB268	Steel	0.180	0.698
CB1948	Steel	0.180	0.690
CB1948R	Steel	0.180	0.698

Template hinges of the hospital type conform to above screw hole location. Hospital type hinges are designated by prefix "HT" to class number.

Machine Screw Size — ½ × 12-24 F.H.

Wood Screw Size — 1¼ × No. 12 F.H.

