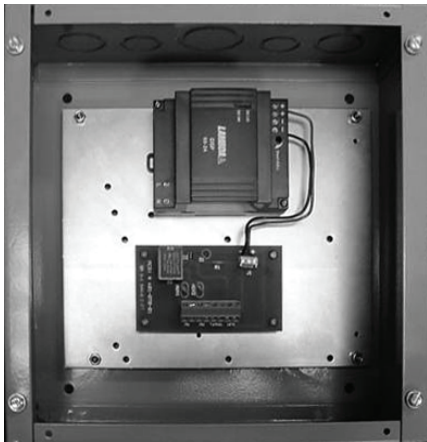


# 8Q00314 Power Supply Installation Instructions



## Features

- Filtered/Regulated 24 Volts DC
- Up to Full 2 Amps Load Capacity
- Class 2 Rated Outputs
- Overload, Over Voltage, and Short Circuit Protection
- Automatically Accepts 120VAC or 240VAC Input Without Requiring to Move Jumpers or Set Dip Switches
- Controls EL (Fail Safe) or EU (Fail Secure) Locking Devices
- Interface Relay Isolates Locking device current from control switch
- Auxilary 24VDC Constant Voltage Output for Powering Stand Alone Devices, Such as Keypads, Motion Detectors, and Status Indicators
- Surge Suppression on Fail Safe and Fail Secure Outputs
- UL Listed and Tested to 294 Standard for Access Control System Units

## Installing 8Q00314

The unit must be mounted indoors and away from any moist or wet areas. Some common locations for mounting the 8Q00314 would be in the plenum near the door containing the electric locking device, or in a nearby closet or electrical room.

When installing the unit in the plenum, wires must either be of plenum rating or contained inside conduit. The unit must be mounted in a vertical position with the power supply module located at the top, as shown in the photograph above.

Four 1/4" holes are provided for mounting the box to the wall or other rigid surface. If the surface material is wood, it must be at least 1" thick. Use either a truss or panhead, 1" long sheet metal screw (#10 or larger) for fastening the box to the wood surface. When mounting the unit to 1/2" or 5/8" dry wall, it is recommended that 3/16" or 1/4" diameter toggle bolts be used for maximum support. Use the same size toggle bolts for mounting the unit to hollow concrete blocks.

For mounting to concrete, solid block, or brick, it is recommended to use 1-3/4" long (min.) x 1/4" diameter hex head bolt anchors (sometimes called power-bolts) in a 18-8 stainless steel or Grade 5 zinc-plated steel. The sub plate can be removed from the box for easier access to the mounting holes. To remove the subplate, locate the four #6 locknuts near each corner of the plate and remove. The 6-32 studs, from which the sub plate mounts to, are held in place to the box by threaded standoffs.

## Wiring the AC Input

The 8Q00314 power supply is rated for use with a 20 amp branch circuit and is capable of accepting either 120 VAC or 240VAC input without the need for making any changes, or reconfiguring to convert from one input voltage to the other. Because the power supply module contains Class 2 double insulation, an earth ground wire is not required. For wiring 120VAC or 240VAC input, run 14 AWG 2-conductor to the power supply module's input terminals marked L (Line) and N (Neutral). Ensure that the conductors are fully inserted into the input terminals with no bare metal exposed. (Refer to the wire stripping instructions included on the wiring diagram attached to the cover plate of this power supply).

**CAUTION!** It is important to maintain separation between the primary (high voltage AC) wiring and secondary (low voltage DC) wiring as they are routed inside the power supply enclosure. All secondary wiring must be routed through any one of the knockouts located along the bottom wall of the enclosure. The primary wiring must be run inside conduit; and the conduit must be connected to one of the knockouts located towards the left end of the top wall of the enclosure (above and to the left of the power supply module's input terminals).



This unit is not equipped with a battery standby power feature.

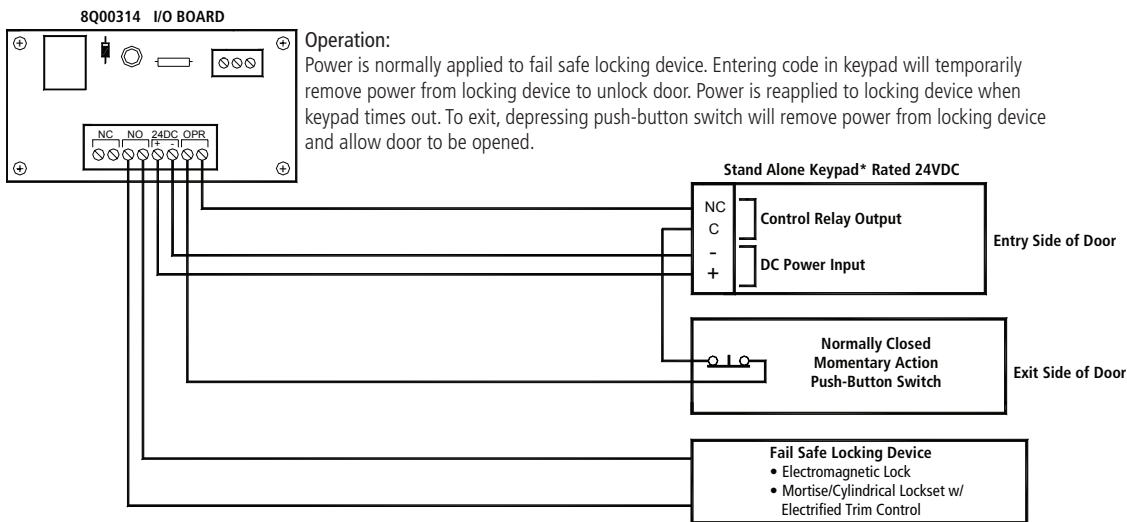
## Control Switch

Used for indirectly switching power to EL (fail safe) and EU (fail secure) locking devices, a control switch can be momentary or maintained action, depending on the application. A control switch can be in the form of relay contacts, such as used in card reader systems, motion detectors, or stand alone keypads. Key switches, push-button switches, and emergency release type switches (including fire alarm contacts) can also be used as a control switch for local or remote switching of electric locking devices. It is important to ensure that the switching device be in the form of “dry” contacts only (no voltage riding on the switch contacts, usually referred to as “wet” contacts).

The control switch actually energizes and de-energizes an on board interface relay. The purpose for the relay is to isolate locking device current from the control switch contacts. Using this method of control, switches with low current ratings can be used without the risk of becoming damaged from the higher current of the locking device, which can be 0.5 amp or greater. The control switch will only see low relay current (15mA) passing through its contacts. The higher current drawn from the locking device will be switched through the heavy duty 7 amp rated contacts of the interface relay.

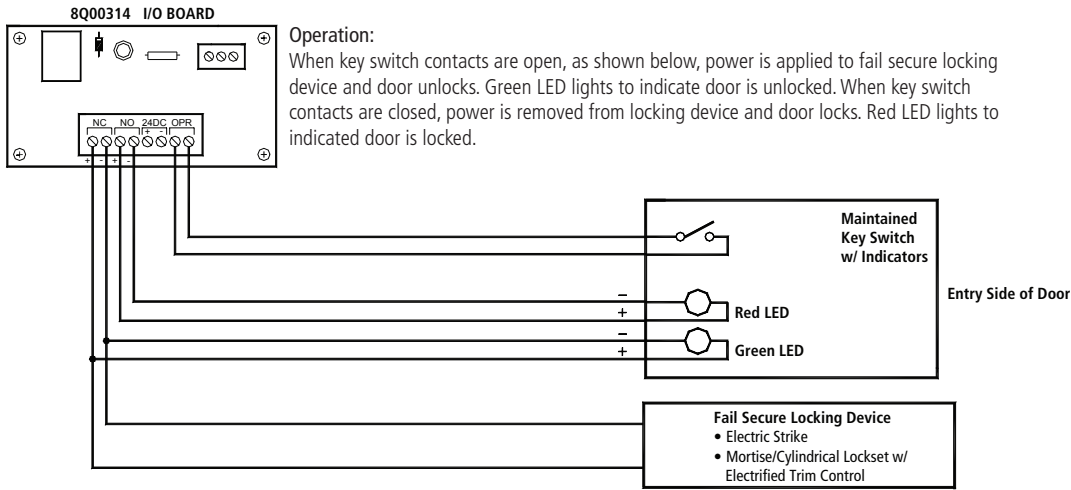
**Note:** To keep line drop (voltage lost due to resistance in the field wire) to a minimum, it is recommended that an 18 gauge stranded two conductor cable be run from the 8000314 to each electrified locking device (or two locking devices if required on pair door applications). Each separate run must not exceed 500 feet. The control switch, however, can be located several hundred feet further from the power supply with hardly any voltage lost on account of the high impedance of the relay coil (1,6000Ω, or 1600 ohms).

The illustrations below are wire diagram examples for wiring a typical EL (fail safe) and EU (fail secure) system using combinations of available inputs and outputs:



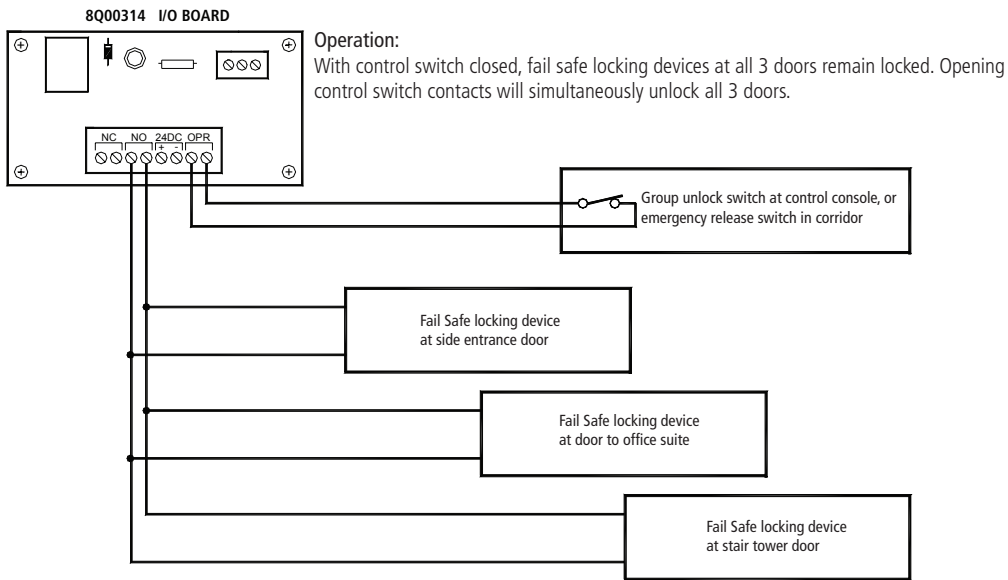
\*To be installed inside secure area only. Stand Alone configuration not suitable in an outside attack situation.

**Fig 1: Wire Scheme for a Typical Fail Safe System**

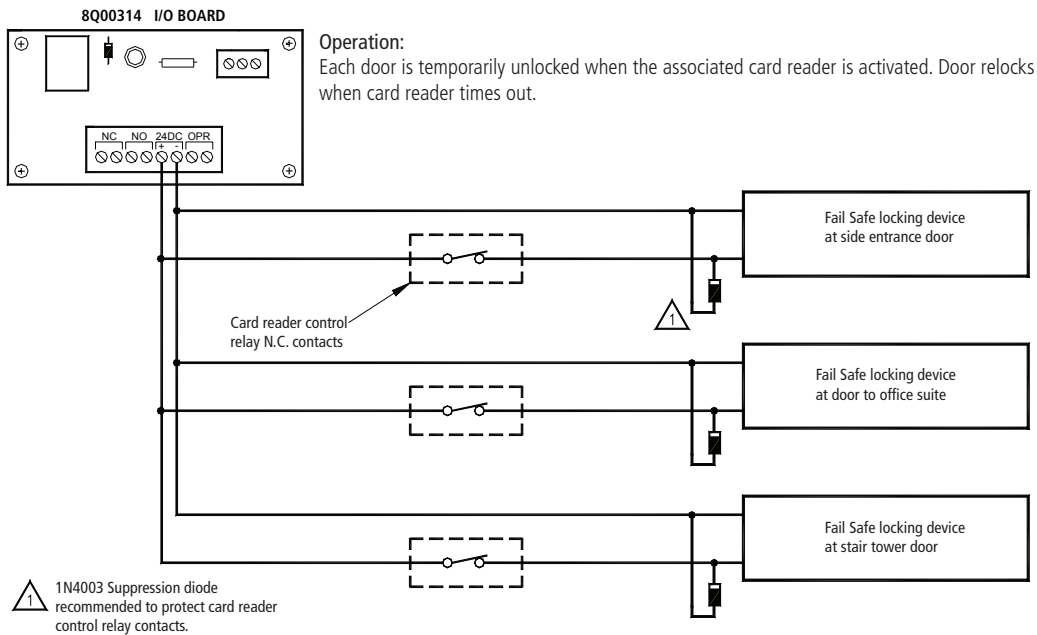


**Fig 2: Wire Scheme for a Typical Fail Secure System**

Figure 3 below shows use of more than one locking device simultaneously locked and unlocked by one control switch. Figure 4 illustrates multiple locking devices controlled independently by a card reader system:



**Fig 3: Wire Scheme for Simultaneous control of multiple doors**



**Fig 4: Wire Scheme for Independent control of multiple doors**

Applications illustrated in Figures 3 and 4 can be combined to provide both independent and simultaneous control of doors as follows: In Figure 4, move the two-wire circuit of the three EL (fail safe) locking devices from the terminals marked "24DC" (constant 24 volt output) to the terminals marked "NO" (EL fail safe output). Connect terminals marked "OPR" (control switch input) to either the fire alarm, an emergency release switch or a group unlock switch. The control switch is normally closed to lock all doors and allow them to be independently unlocked by card readers. When the control switch is opened, all doors unlock together.

### Trouble Shooting Tips

Listed below are some problems that might be encountered during installation, or at any other time, and possible solutions for correcting them.

#### CAUTION!

THIS UNIT CONTAINS AREAS OF EXPOSED HIGH VOLTAGE. ALL TROUBLE SHOOTING AND MAINTENANCE SHOULD BE PERFORMED BY A QUALIFIED ELECTRICIAN.

#### No output voltage measured across terminals NC, NO, and 24DC.

- Check for 120VAC across terminals of input to power supply module.
- If 120VAC is present, disconnect field wires from all used outputs (NC, NO, 24DC) and measure for 24VDC across the "24DC" terminals.
- If 24VDC is now present, check for shorts across field wires for each output.
- If the load is an electrified locking device mounted in the door, check the electric hinge for pinched wires behind each leaf. Also check for shorted wires between the locking device and raceway in the door.
- If 24VDC is not present across terminals marked "24DC" (with field wires still disconnected from all outputs), disconnect the red and black wire leads connected to the +,-terminals of the output to the power supply module and check for 24VDC at this output. If voltage is now present across the power supply module's output, it can be assumed that there is a short circuit somewhere on the control board and it will need to be replaced.
- If voltage is still not present across the output to the power supply module, then it can be assumed the power supply module itself is damaged and must be replaced.

**The electrified locking device behaves the opposite of what was expected, i.e., it locks when intended to unlock, or unlocks when intended to lock.**

- An EL (fail safe) type locking device may be incorrectly wired to the fail secure output terminals (NC). It must be wired to the terminals marked "NO".
- An EU (fail secure) type locking device may be incorrectly wired to the fail safe output terminals (NO). It must be wired to the terminals marked "NC".
- Make sure that the electric locking device has been correctly modified for the function intended: EL Fail Safe (power to lock), EU Fail Secure (power to unlock).
- The control switch may be incorrectly wired. To lock an EL (fail safe) or EU (fail secure) electric locking device, the control switch must be closed. To unlock an EL (fail safe) or EU (fail secure) electric locking device, the control switch must be open.

**The electric locking device does not unlock when a control device, such as a card reader or keypad, is activated.**

- The control output from the card reader or keypad must be in the form of dry contacts and wired across the terminals marked "OPR". In some cases, card readers and keypads put out a switched voltage output when activated. Check these outputs with a voltmeter to ensure that there is no AC/DC voltage present across these outputs when activated or deactivated.

#### **8Q00314 SPECIFICATIONS:**

- Input Voltage: 120VAC/240VAC,50/60Hz
- AC Current: 900mA/120VAC, 600mA/240VAC
- Output Voltage: 24VDC Filtered, Regulated
- Output Current: 2.0A
- Output Power: 48W
- Protection: Overload, Over Voltage, Short Circuit