

# Installation Instructions: Latch Bolt Monitoring LSRK296 / LDSRK298 Conversion Kit

For online instructions, assistance or warranty information:  
Call 1-800-392-5209 or visit <https://dhwsupport.dormakaba.com/hc/en-us>

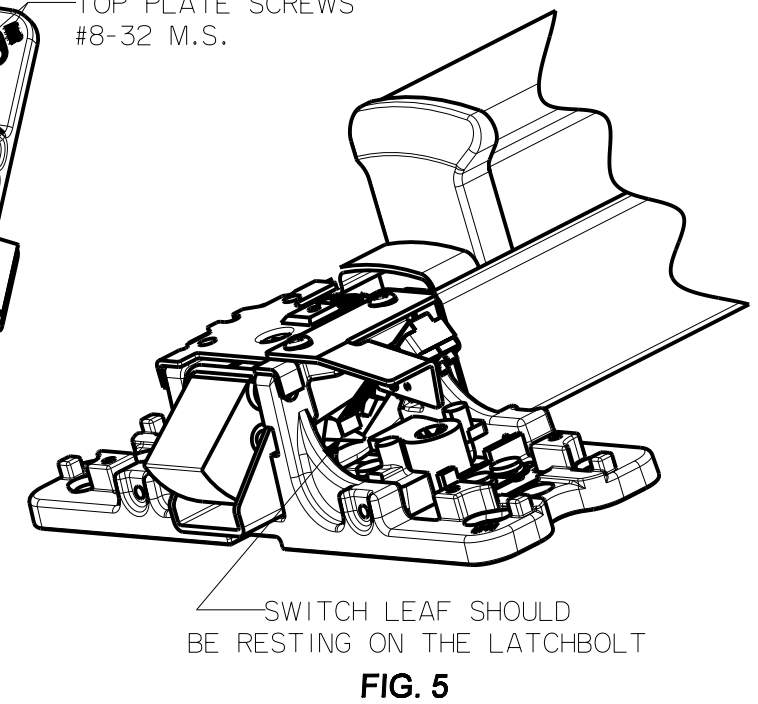
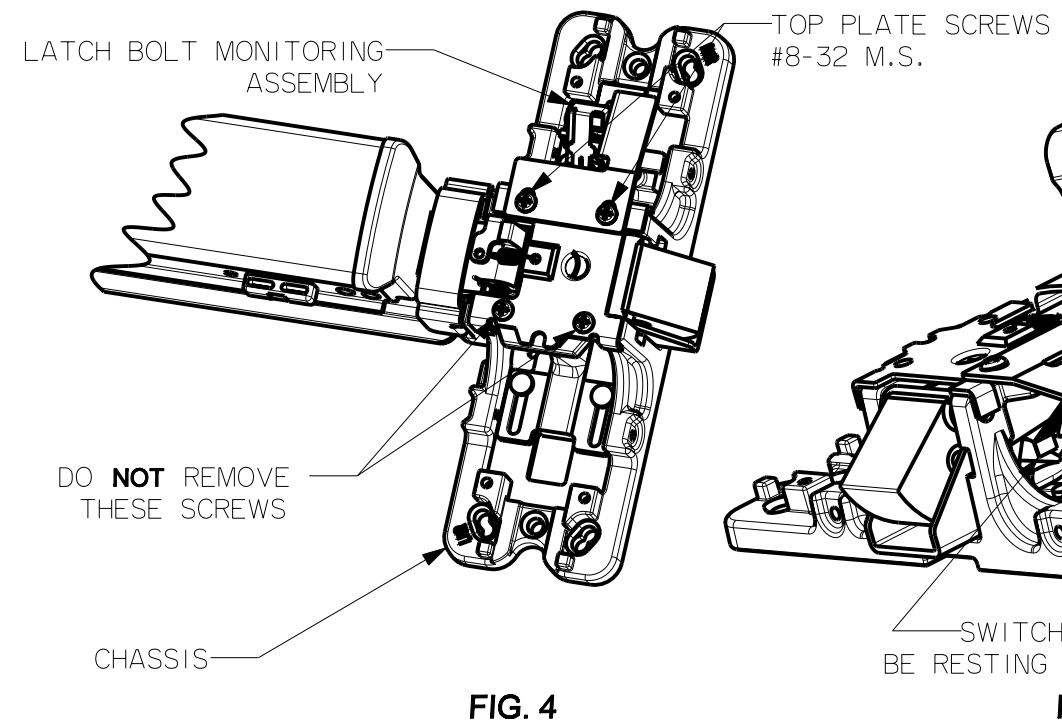
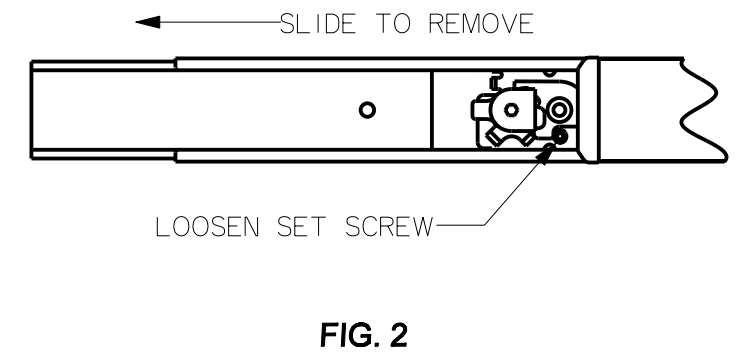
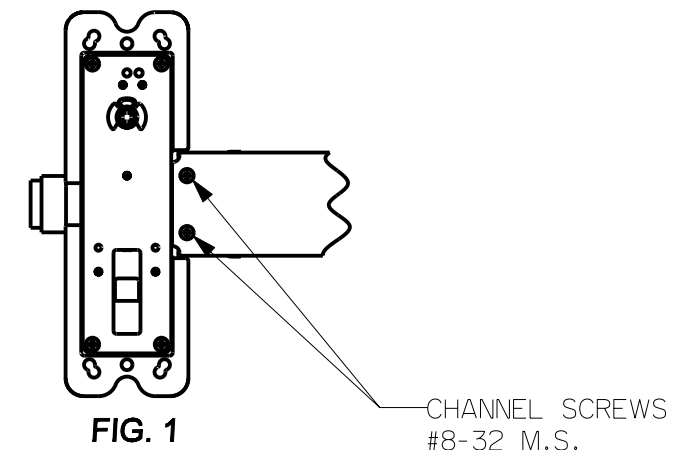
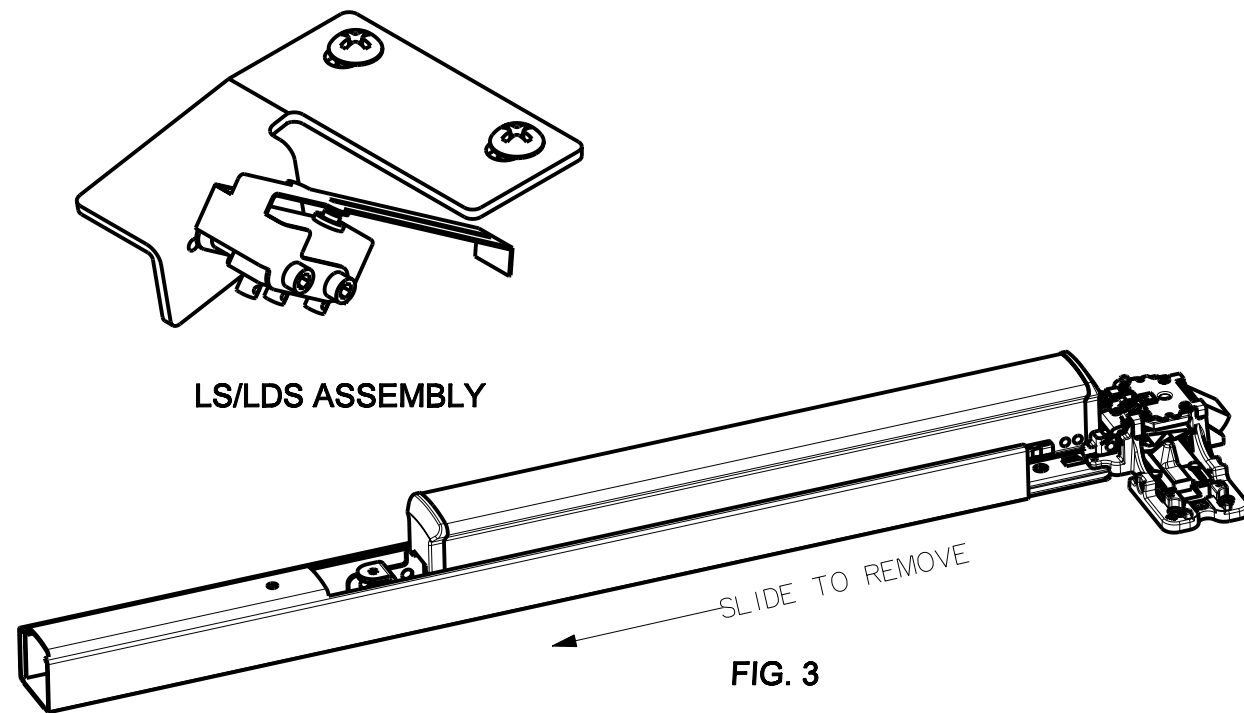

- 1 - Remove the 2 channel screws (Fig. 1) Loosen set screw (FIG 2) and slide device channel away from chassis. (FIG. 3)
- 2 - Remove the 2 Top Plate screws shown and attach the latch bolt monitoring assembly (FIG. 4) Position the switch leaf under the latchbolt as shown (FIG. 5) When the latchbolt is pushed in, a switch closure should appear across the tan and yellow wires
- 3 - Carefully route the wires through the chassis, into the wire run slots and down the subplate. (Fig. 6) Secure wires with tape.
- 4 - Slide device channel back to the chassis and secure it with Channel screws. Snug the set screw and slide in the hinge filler

**NOTE:** For wiring details refer to drawing # 01852-II-000 for electrical information.

