

Installation Instructions: Latch Bolt Monitoring for Vertical Rod Devices LSVK910 Conversion Kit

For online instructions, assistance or warranty information:
Call 1-800-392-5209 or visit <https://dhwsupport.dormakaba.com/hc/en-us>

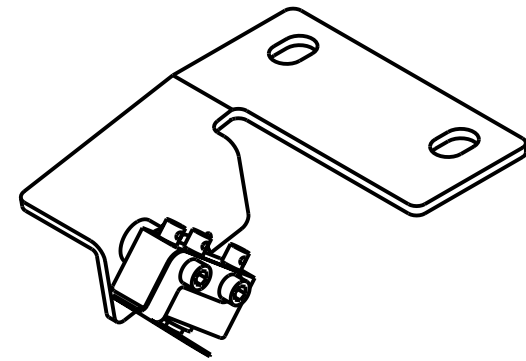

LS ASSEMBLY

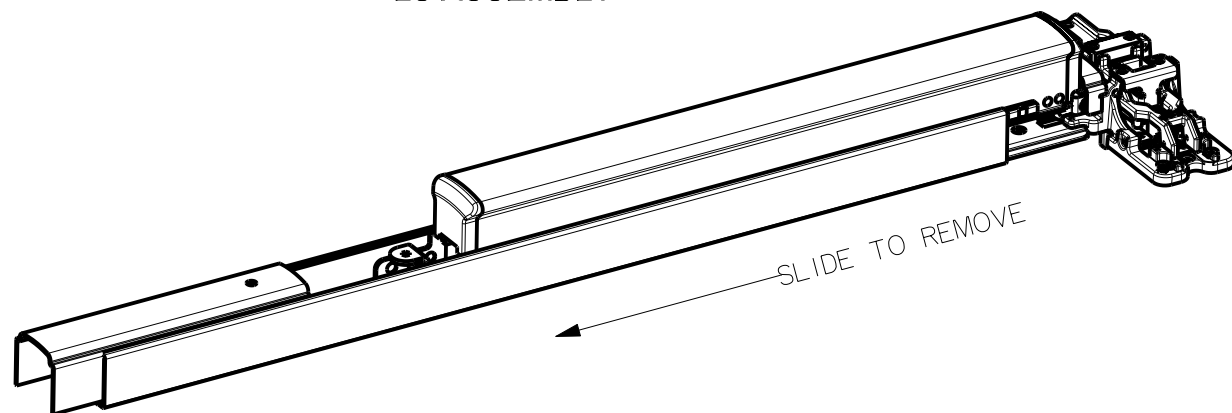

FIG. 3

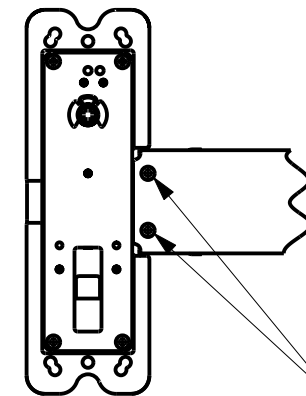

FIG. 1

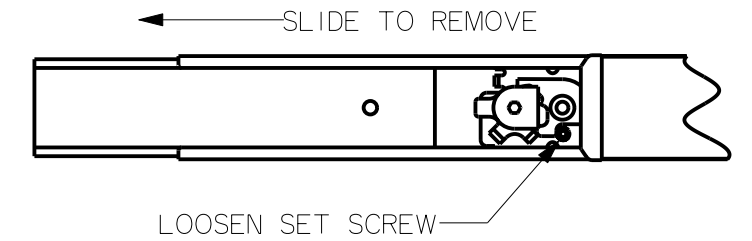

FIG. 2

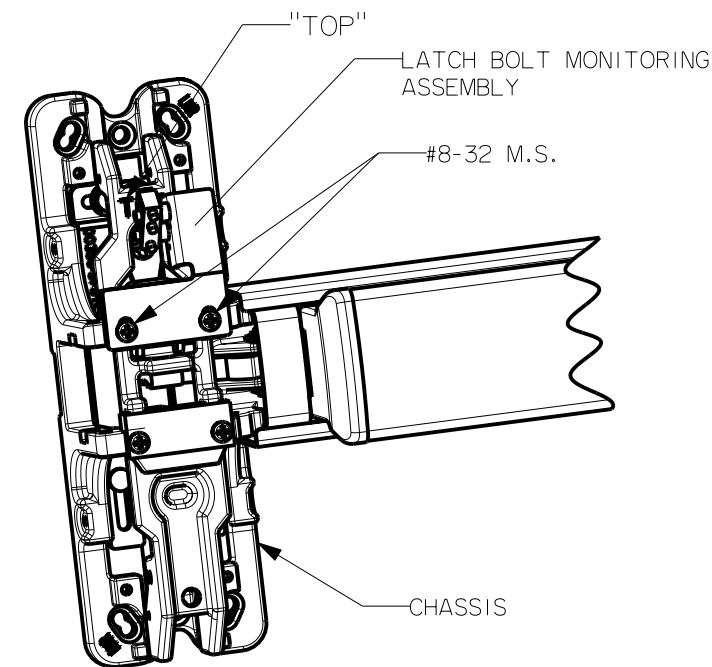

FIG. 4

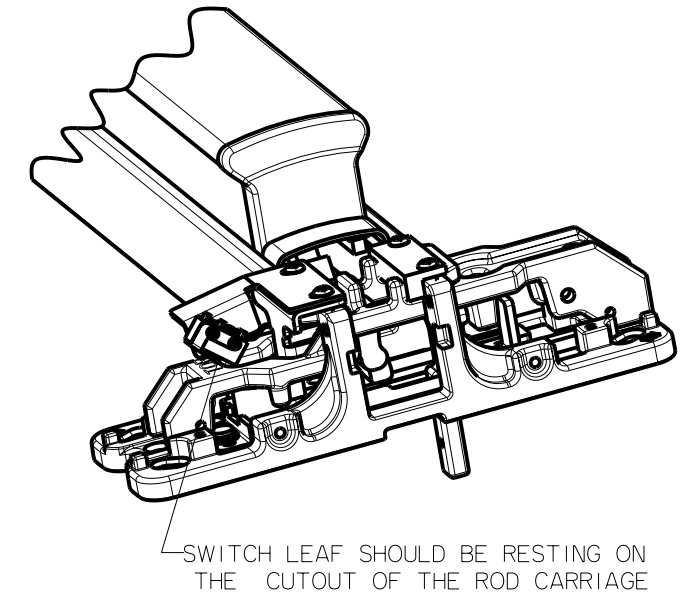

FIG. 5

- 1 - Remove the 2 channel screws (Fig. 1) Loosen set screw (FIG 2) and slide device channel away from chassis. (FIG. 3)
- 2 - Remove the 2 screws shown and attach the latch bolt monitoring assembly (FIG. 4) Position the switch leaf under the TOP side of the Rod Carriage cut out as shown (FIG. 5) When the Rod Carriage is pushed up, a switch closure should appear across the tan and yellow wires.
- 3 - Carefully route the wires through the chassis, into the wire run slots and down the subplate. (Fig. 6) Secure wires with tape.
- 4 - Slide device channel back to the chassis and secure it with screws. Snug the set screw and slide in the hinge filler

NOTE: For wiring details refer to drawing # OI852-II-000 for electrical information.

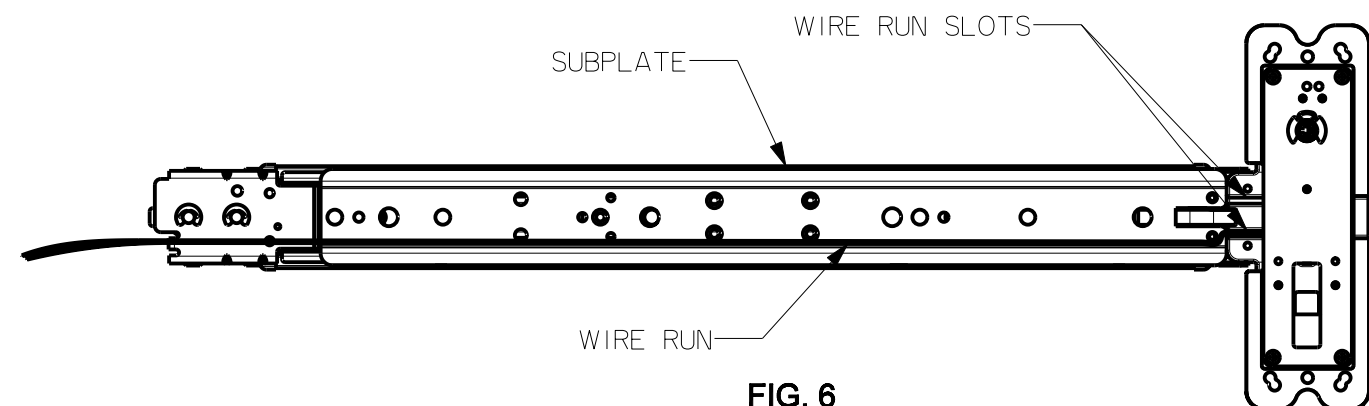

FIG. 6