

Delayed Egress Exit Devices

Electrical Installation Instructions

Table of contents

1	Important safety information	3
1.1	Safety warnings	3
2	Technical specifications	3
2.1	Tools needed	3
2.2	Measurements	3
3	Device preparation	4
3.1	Planning site survey	4
3.2	Changing handing	4
3.3	Electrical specifications	4
3.4	PS 1 6 1-6 power	4
4	Installation instructions	5
4.1	Installing components	5
4.2	Installing key cylinder	6
4.3	Accessing electronics	6
4.4	Pulling wire to device and plugging in wire harness	7
4.5	Identifying wires and function	7
4.6	Connecting power and fire	8
4.7	Making other connections	8
4.8	Setting mode select switches	10
4.9	Operating DE device	11
4.10	Typical applications	12
4.11	Troubleshooting	15

1 Important safety information

1.1 Safety warnings

1.1.1 Safety instructions: To reduce risk of injury or damage, carefully read and follow safety warnings, cautions and notices provided.

1.1.2 Safety warnings: Indicates a hazardous situation which, if not avoided, could result in death or serious injury.

WARNING

- WARNING! Disconnect power before making any electrical connections.
- WARNING! Power down the device before changing these switches.

1.1.3 Safety cautions: Indicates a hazardous situation which, if not avoided, could result in minor or moderate injury.

CAUTION

- CAUTION! There are no user-serviceable parts in electronics or locking mechanism. Internal touch bar monitoring switch is factory-set; tampering with this switch may result in device malfunction during an emergency.

1.1.4 Notice: Indicates information considered important but not directly hazard-related.

NOTICE

- Test device periodically to ensure proper operation.

2 Technical specifications

2.1 Tools needed

Table 1

Phillips head screwdriver	Level	Drill bits: 5/8"
Flat head screwdriver	Drill	

2.2 Measurements

2.2.1 All dimensions are given in inches [millimeters].

3 Device preparation

3.1 Planning site survey

Site survey

Complete the following survey to document details about the installation site. This information is essential for determining the proper door preparation for the lock.

3.2 Changing handing

Fig.1

Figure 1 Door handing diagram

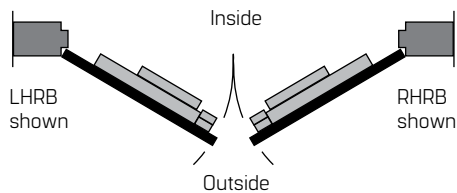

Door information

Door handing and bevel:

- Left hand, reverse bevel (LHRB)
- Right hand, reverse bevel (RHRB)

Door thickness: _____ inches
 1 - 3/4" [44.45] to 2 - 1/4" [57.15]

3.3 Electrical specifications

Table 2

Electrical specifications	
Spec	Rating
Voltage	24 VDC regulated and filtered
Current armed	3.2 amps for 0.2 sec., then 0.2 amps steady state
Current disarmed	0.1 amps
Alarm relay contacts	1 amp @ 24 VDC
Secure relay contacts	1 amp @ 24 VDC
Time delay period	Standard: 15 seconds Optional: 30 seconds is available where approved by authority having jurisdiction. NOTE: This setting is not field selectable.

3.4 PS 161-6 power

Table 3

PS 161-6 power supply battery backup feature	
Feature	Description
Built-in charger	Designed for sealed lead acid batteries.
Automatic switchover	Switches to standby battery power when AC fails.
Maximum charge current	0.7 amp.
Zero voltage drop	No voltage loss when switching to battery backup.
Battery capacity	PS 161-6 enclosure supports up to two 12VDC/7 AH batteries.
Standby time	Two 12V, 7 AMP batteries connected in series provide approximately two hours of standby power.

4 Installation instructions

4.1 Installing components

Table 4

Prepare opening

- 4.1.1 Select appropriate application and use proper templates to prepare door and frame.

Install DE exit device

- 4.1.2 Follow installation instructions provided with DE device to ensure proper mounting and operation.

⚠ WARNING! Disconnect power before making any electrical connections.

NOTE: DE device requires a UL-approved Precision hardware power supply (model PS 16 1-6).

NOTE: This power supply is available with battery backup for continued operation during power loss.

Required: electrical transfer device installation

- 4.1.3 Install required electrical (conduit) transfer device (e.g., electric hinge, door loop, EPT) following manufacturer's instructions.

Required: door preparation

- 4.1.4 Machine hinge stile of door according to Template number T93668.

Required: fire alarm system connection

- 4.1.5 DE device must be connected to fire alarm system per prevailing codes.

NOTE: Fire alarm connection can be made at power supply, or DE device.

The number of external components in the system determines the number of conductors required for the wire run.

1. Power wires must be 18 AWG or larger.
2. Signal wires must be 22 AWG or larger.

See Table 4 below to determine the appropriate wire gauge for your installation.

Table 4

	Distance in feet from power source to farthest locking device				
Feet:	25'	50'	75'	100'	150'
AWG (wire gauge)	18	16	16	14	12

Optional: fire alarm system connection

- 4.1.6 Install any optional external components (e.g., card readers, remote switches, voice modules) according to manufacturer's instructions.

NOTE: Components are not verified by UL.

NOTICE

Ensure that all devices connected to DE device are UL-listed equipment.

Install instructional label

NOTE: Included label: "Push until alarm sounds. Door can be opened in 15 seconds."

- 4.1.7 Position and affix label centered on door, one foot above DE device.

NOTE: Depending on application, the label you may have received with the DE Device could state that the door can be opened in "30 seconds" instead of "15 seconds."

4.2 Installing key cylinder

Fig. 2

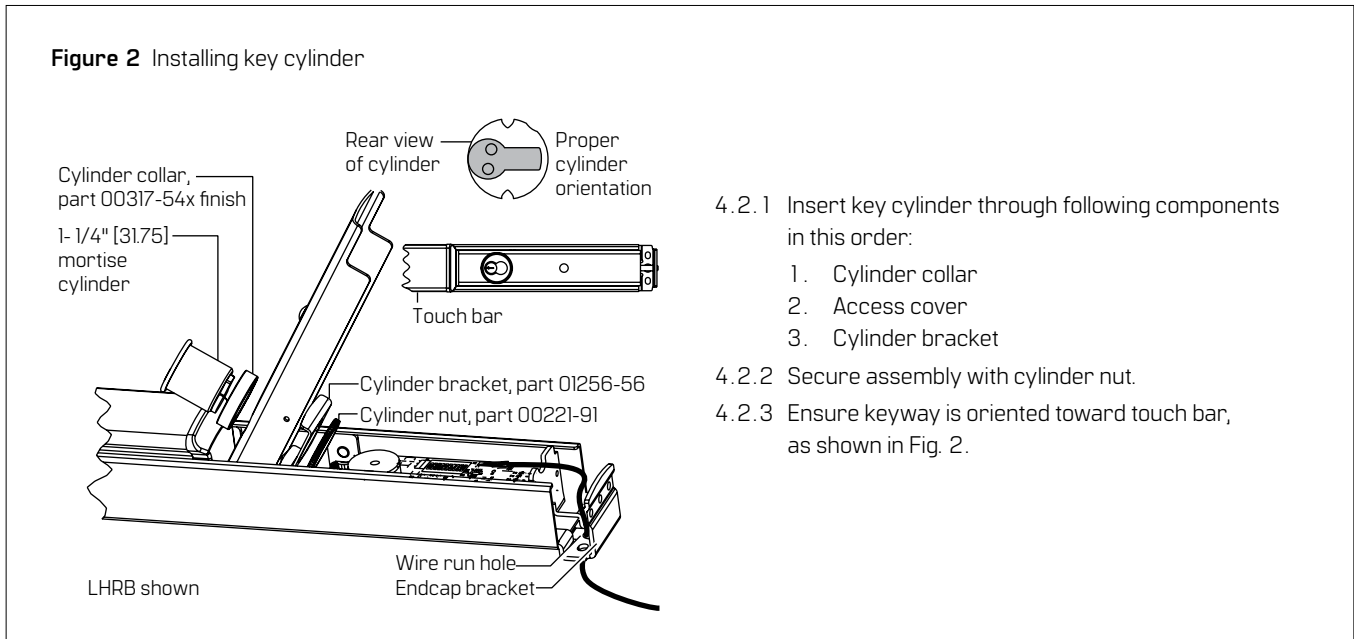

4.3 Accessing electronics

Fig. 3

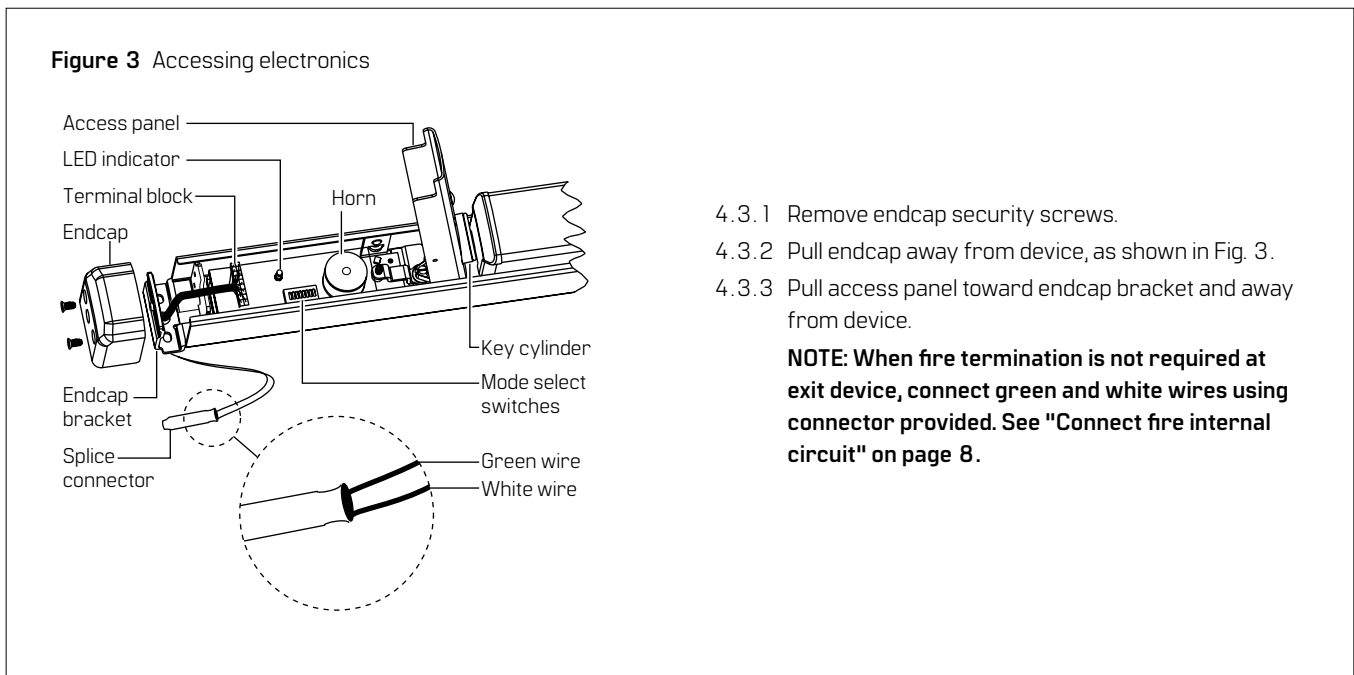

4.4 Pulling wire to device and plugging in wire harness

Fig. 5

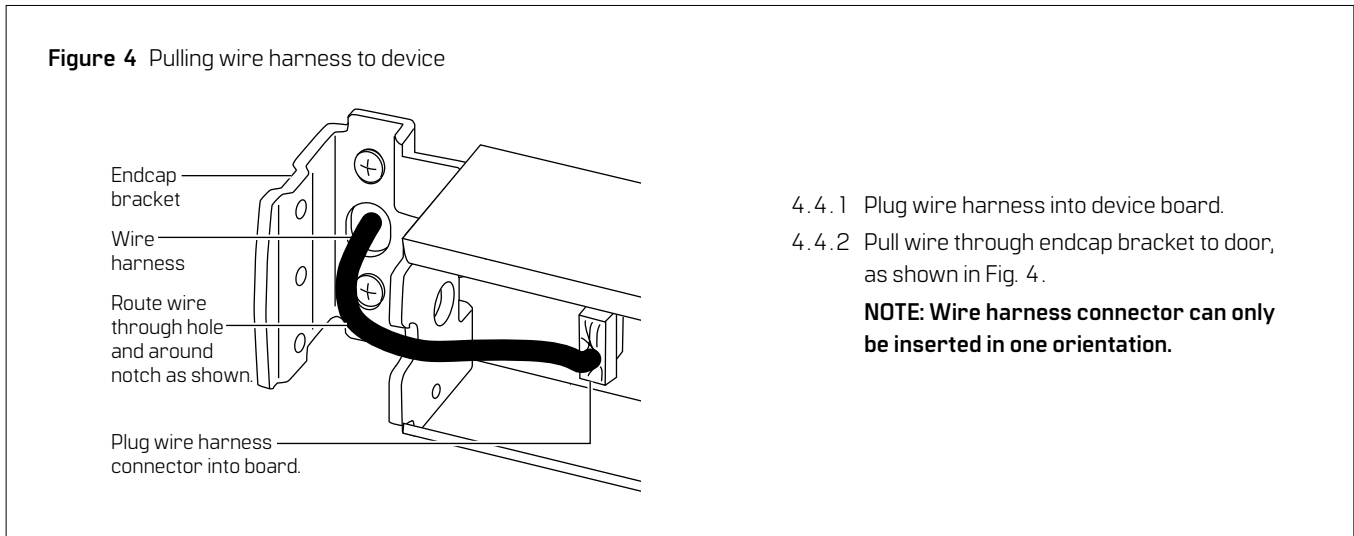

4.5 Identifying wires and function

Fig. 5, Table 5

Wiring harness description

4.5.1 Use following table to identify wires and their functions.

Table 5

Pin loc	Wire description	Wire color	Wire gauge (AWG)
1	-24 VDC	Black	22
2	+24 VDC	Red	22
3	Fire alarm 1	Green	22
4	Fire alarm 2	White	22
5	External inhibit	Red/White	24
6	External inhibit	Green/White	24
7	Devnet +	Orange	24
8	Devnet -	Orange/White	24
9	Devnet_ref	Black/White	24
10	S Relay (NC)	Brown	24
11	S Relay (NO)	Gray	24
12	S Relay (Com)	Violet	24
13	A Relay (NC)	Brown/White	24
14	A Relay (NO)	Gray/White	24
15	A Relay (Com)	Violet/White	24
16	Door position switch	Blue	24
17	Door position switch	Blue/White	24

Figure 5 Wiring harness label

Located on underside of access panel, as shown in Fig. 4.

Actual size of wiring harness label

Enlarged

J3										
1	2	3	4	5	6	7	8	9		
10	11	12	13	14	15	16	17	18		
Pin	Pin	Wire								
Location	Description	Color								
1	-24VDC	BLACK								
2	+24VDC	RED								
3	FIRE1	GRN								
4	FIRE2	WHT								
5	EXTINHIB	RED/WHT								
6	EXTINHIB	GRN/WHT								
7	DEVNET+	ORG								
8	DEVNET-	ORG/WHT								
9	DEVNET_REF	BLK/WHT								
10	SRELAYNC	BRN								
11	SRELAYNO	GRY								
12	SRELAYC	VIO								
13	ARELAYNC	BRN/WHT								
14	ARELAYNO	GRY/WHT								
15	ARELAYC	VIO/WHT								
16	DPSSW	BLU								
17	DPSSW	BLU/WHT								
18										

4.6 Connecting power and fire

Fig. 6

Figure 6 Simple delayed egress device with fire alarm

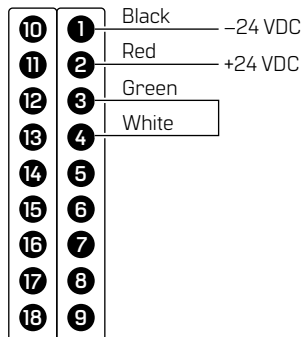

NOTE: DE device requires a UL-approved Precision hardware power supply (model PS 1 6 1-6).

NOTE: Connect a maximum of four DE Exit Device units to a single PS 1 6 1-6 power supply.

4.6.1 Connect RED wire to +24 VDC.

4.6.2 Connect BLACK wire to -24 VDC.

NOTE: For most applications, follow this step.

However, see "Door position with fire alarm" on page 12 for an alternate fire application.

NOTE: Ensure that all connections between DE exit devices and fire panel are set to fail-safe mode.

4.6.3 Connect GREEN and WHITE wires, as shown in Fig. 6.

4.6.4 Connect fire circuit contact to power supply.

NOTE: Refer to power supply installation instructions for additional details.

Description of operation

During a fire alarm, DE device loses power and functions as a normal exit device.

4.7 Making other connections

Fig. 7

Figure 7 Two DE networked devices with fire alarm

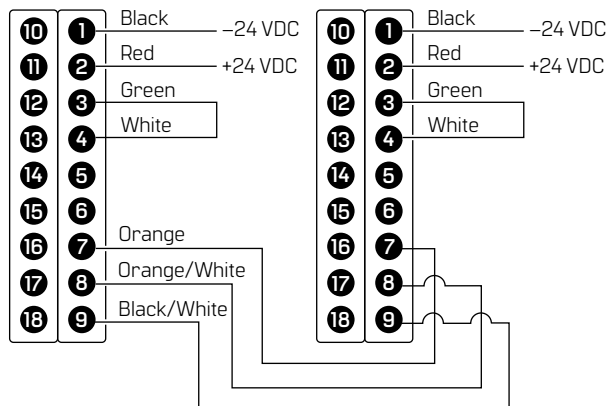

Device networking

4.7.1 Connect "Orange" wire of one DE device to "Orange" wire of another DE device, as shown in Fig. 7.

4.7.2 Connect "Orange/White" wire of one DE device to "Orange/White" wire of another DE device, as shown in Fig. 7.

4.7.3 Connect "Black/White" wire of one DE device to "Black/White" wire of another DE device, as shown in Fig. 7.

4.7.4 Set mode select switches as needed. See "Set mode select switches" on page 10.

Description of operation

Feature enables a DE device to arm, alarm, reset, and disarm all DE devices within connected circuit. Each DE device will still function independently for momentary egress.

NOTE: If interconnected wiring fails, each unit will operate independently or default to fail-safe mode.

Fig. 8, Fig. 9

Figure 8 Connecting a card reader, keypad, or other external inhibiting input device

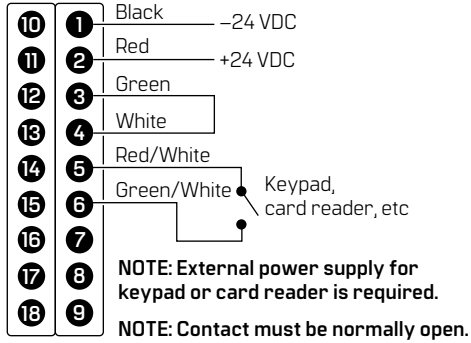

External inhibit

4.7.1 Connect "Red/white" and "Green/white" wires to an external inhibiting device, such as a card reader, keypad, or other input, as shown in Fig. 8.

Description of operation

Alarm mode: When the switch contact is closed during the alarm mode, the DE device will reset to the armed mode.

Off mode: When the switch contact is closed during the off mode, the DE device will reset to the armed mode, if approved by local authority having jurisdiction.

Armed mode: When the switch contact is closed during the armed mode the DE device will remain unarmed until the contact opens. The DE device will then relock and be armed after the contact opens.

Figure 9 Connecting a secure relay lamp

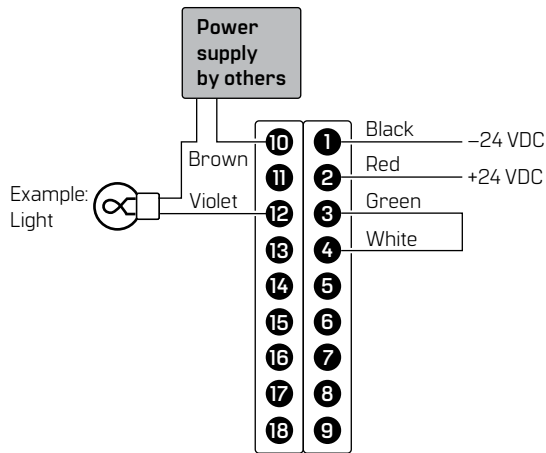

Secure relay

4.7.1 Connect "Brown" and "Violet" wires to an indicator, such as a light, as shown in Fig. 9.

Description of operation

In this example, the secure relay controls a lamp to indicate an unsecured opening. The internal SPDT relay toggles when the device is armed.

- Internal relay rating: 1 amp @ 24 VDC

Figure 1 0 Connecting an alarm relay sounder

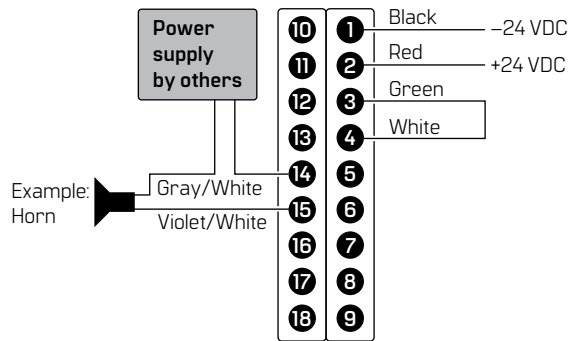

Alarm relay

4.7.1 Connect "Gray/White" and "Violet/White" wires to an indicator, such as a horn, as shown in Fig. 1 0.

Description of operation

In this setup, the alarm relay controls a remote powered horn. The internal SPDT relay toggles when the device is alarmed.

- Internal relay rating: 1 amp @ 2 4 VDC

Figure 1 1 Connecting a door position switch

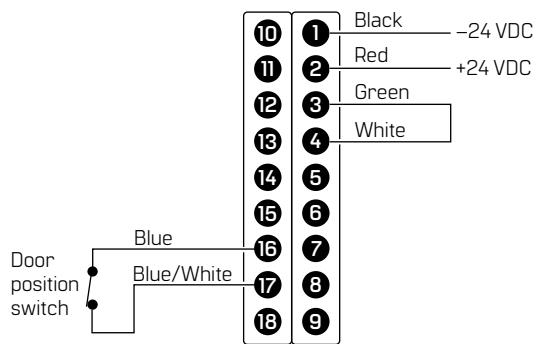

Precision part number: DS880

Door position switch

4.7.1 Connect "Blue/White" and "Blue" wires to a door position switch, as shown in Fig. 1 1.

4.7.2 Set mode select switch #7 to ON.

Description of operation

When this input is used the device cannot be armed when the door is opened and if armed, it will alarm the DE device if the door is opened. Also, the arm/re-arm time will end when the door is closed.

4.8 Setting mode select switches

Fig. 1 2

Figure 1 2 Mode select switch (default positions shown)

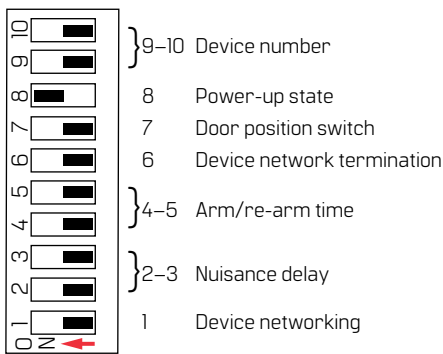

Set mode select switches

DE devices can be set to operate in different modes with various features "On" or "Off". The following three features can be configured while the DE device is powered and in disarmed mode, meaning there is no need to power down the device to adjust these settings.

Configurable powered features include:

- Nuisance delay
- Arm/re-arm time
- Door position sensing

⚠ WARNING! Turn off power to DE device before changing following mode select switches.

- Power-up state
- Device networking (more than one device)

See Table 6 on following page to determine correct mode select switch settings. See Fig. 3 on page 6 for location of mode select switches.

Table 6

Switch																							
No function	Description	Settings	Factory default setting																				
1 Device networking	Enables communication between DE devices. Ignore if only one device is used. NOTE: See pins 9 and 10 to assign an unique device number to each unit.	Set to "On" only if using more than one device. ⚠ WARNING! Power down the device before changing these switches.	No networking																				
2–3 Nuisance delay	Helps to avoid inadvertent activation. The alarm will sound when the touch bar is pressed, but the alarm sequence will stop unless the touch bar is held for programmed time.	<table border="1"> <thead> <tr> <th>Pin 2</th> <th>Pin 3</th> <th>Delay</th> </tr> </thead> <tbody> <tr> <td>Off</td> <td>Off</td> <td>0 sec</td> </tr> <tr> <td>Off</td> <td>On</td> <td>1 sec</td> </tr> <tr> <td>On</td> <td>Off</td> <td>2 sec</td> </tr> <tr> <td>On</td> <td>On</td> <td>3 sec</td> </tr> </tbody> </table>	Pin 2	Pin 3	Delay	Off	Off	0 sec	Off	On	1 sec	On	Off	2 sec	On	On	3 sec	0 seconds					
Pin 2	Pin 3	Delay																					
Off	Off	0 sec																					
Off	On	1 sec																					
On	Off	2 sec																					
On	On	3 sec																					
4–5 Arm/re-arm time	Allows momentary egress of authorized personnel without alarming the DE device. At the end of the time period, the device will relock and re-arm.	<table border="1"> <thead> <tr> <th>Pin 4</th> <th>Pin 5</th> <th>Re-arm</th> </tr> </thead> <tbody> <tr> <td>Off</td> <td>Off</td> <td>0 sec</td> </tr> <tr> <td>Off</td> <td>On</td> <td>10 sec</td> </tr> <tr> <td>On</td> <td>Off</td> <td>20 sec</td> </tr> <tr> <td>On</td> <td>On</td> <td>30 sec</td> </tr> </tbody> </table>	Pin 4	Pin 5	Re-arm	Off	Off	0 sec	Off	On	10 sec	On	Off	20 sec	On	On	30 sec	0 seconds					
Pin 4	Pin 5	Re-arm																					
Off	Off	0 sec																					
Off	On	10 sec																					
On	Off	20 sec																					
On	On	30 sec																					
6 Device networking termination	Enables device networking termination. Use this if switch one is set to "On".	Set to "On" if switch 1 is set to on. Set to "Off" if switch 1 is set to off.	No networking																				
7 Door position switch	Enables door position sensing.	Set to "On" only if a door position switch is installed and wired to the device.	No door position switch																				
8 Power-up state	Determines if the device will be armed or unarmed when power is applied.	Set to "Off" only if you want the device to be unarmed when powering-up the device. ⚠ WARNING! Power down the device before changing these switches.	Device will be armed when powered up.																				
9–10 Device number	Identifies the DE device with a number when more than one device is connected to a single power supply. Each device must have a unique device number. This staggers the arming of devices in device number sequence at 0.2 sec intervals.	<table border="1"> <thead> <tr> <th>Pin 9</th> <th>Pin 10</th> <th>Number</th> <th>Delay (sec)</th> </tr> </thead> <tbody> <tr> <td>Off</td> <td>Off</td> <td>0</td> <td>0.0 (default)</td> </tr> <tr> <td>Off</td> <td>On</td> <td>1</td> <td>0.2</td> </tr> <tr> <td>On</td> <td>Off</td> <td>2</td> <td>0.4</td> </tr> <tr> <td>On</td> <td>On</td> <td>3</td> <td>0.6</td> </tr> </tbody> </table>	Pin 9	Pin 10	Number	Delay (sec)	Off	Off	0	0.0 (default)	Off	On	1	0.2	On	Off	2	0.4	On	On	3	0.6	
Pin 9	Pin 10	Number	Delay (sec)																				
Off	Off	0	0.0 (default)																				
Off	On	1	0.2																				
On	Off	2	0.4																				
On	On	3	0.6																				

4.9 Operating DE device

Table 7

LED indicators	Operating DE device												
See Table 7 to determine the proper operation settings.	Turn the cylinder clockwise or counterclockwise to access all functions of the delayed egress device. See Table 8 on the following page to determine the proper operation settings.												
Table 7	<ul style="list-style-type: none"> • Arm device • Get momentary egress • Reset alarm after alarm has sounded • Disarm device 												
<table border="1"> <thead> <tr> <th>LED</th> <th>Meaning</th> </tr> </thead> <tbody> <tr> <td>Flashing green</td> <td>Arm/re-arm time is active. See arm/re-arm time function on page 11. NOTE: DE device's default is no arm/re-arm time function. So this function must be activated before this LED function will be visible.</td> </tr> <tr> <td>Flashing red</td> <td>Device is armed. This is normal LED function.</td> </tr> <tr> <td>Solid green</td> <td>Device is unarmed.</td> </tr> <tr> <td>Solid red</td> <td>Alarm: Unauthorized exit Device needs to be reset. See page 12.</td> </tr> <tr> <td>None</td> <td>No power or fire alarm.</td> </tr> </tbody> </table>	LED	Meaning	Flashing green	Arm/re-arm time is active. See arm/re-arm time function on page 11. NOTE: DE device's default is no arm/re-arm time function. So this function must be activated before this LED function will be visible.	Flashing red	Device is armed. This is normal LED function.	Solid green	Device is unarmed.	Solid red	Alarm: Unauthorized exit Device needs to be reset. See page 12.	None	No power or fire alarm.	
LED	Meaning												
Flashing green	Arm/re-arm time is active. See arm/re-arm time function on page 11. NOTE: DE device's default is no arm/re-arm time function. So this function must be activated before this LED function will be visible.												
Flashing red	Device is armed. This is normal LED function.												
Solid green	Device is unarmed.												
Solid red	Alarm: Unauthorized exit Device needs to be reset. See page 12.												
None	No power or fire alarm.												

Table 8

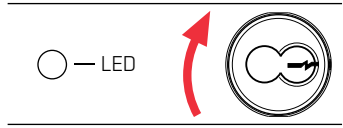
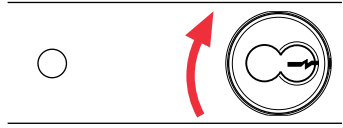
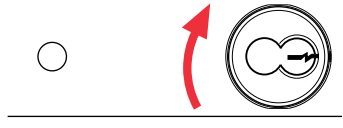
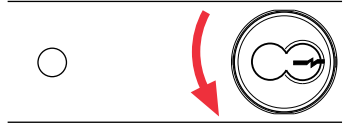
DE device		
Function	Diagram ^a	Description
Arm device		With the power applied, turn the key clockwise ^b . The LED indicator will flash red and the touch bar will lock (factory default operation). See "LED indicators" on page 11.
Get momentary egress		With the DE device armed and the arm/ re-arm time activated, turn the key clockwise. The LED indicator will flash green and the touch bar will unlock for the selected amount of time. See "Set mode select switches" on page 10 to set the momentary egress time for 10, 20 or 30 seconds. See "LED indicators" on page 11.
Reset alarm		When the DE device is alarming, it can be reset by turning the key clockwise ^b , returning the device to the armed state. See "LED indicators" on page 11.
Disarm device		With the DE device armed, turn the key counterclockwise ^b . The LED indicator will light green and the touch bar will unlock, acting as a normal exit device. See "LED indicators" on page 11.

a. RHRB shown.

b. Turn and hold key for two seconds to send function command to other networked devices.

4.1.0 Typical applications

Fig. 14

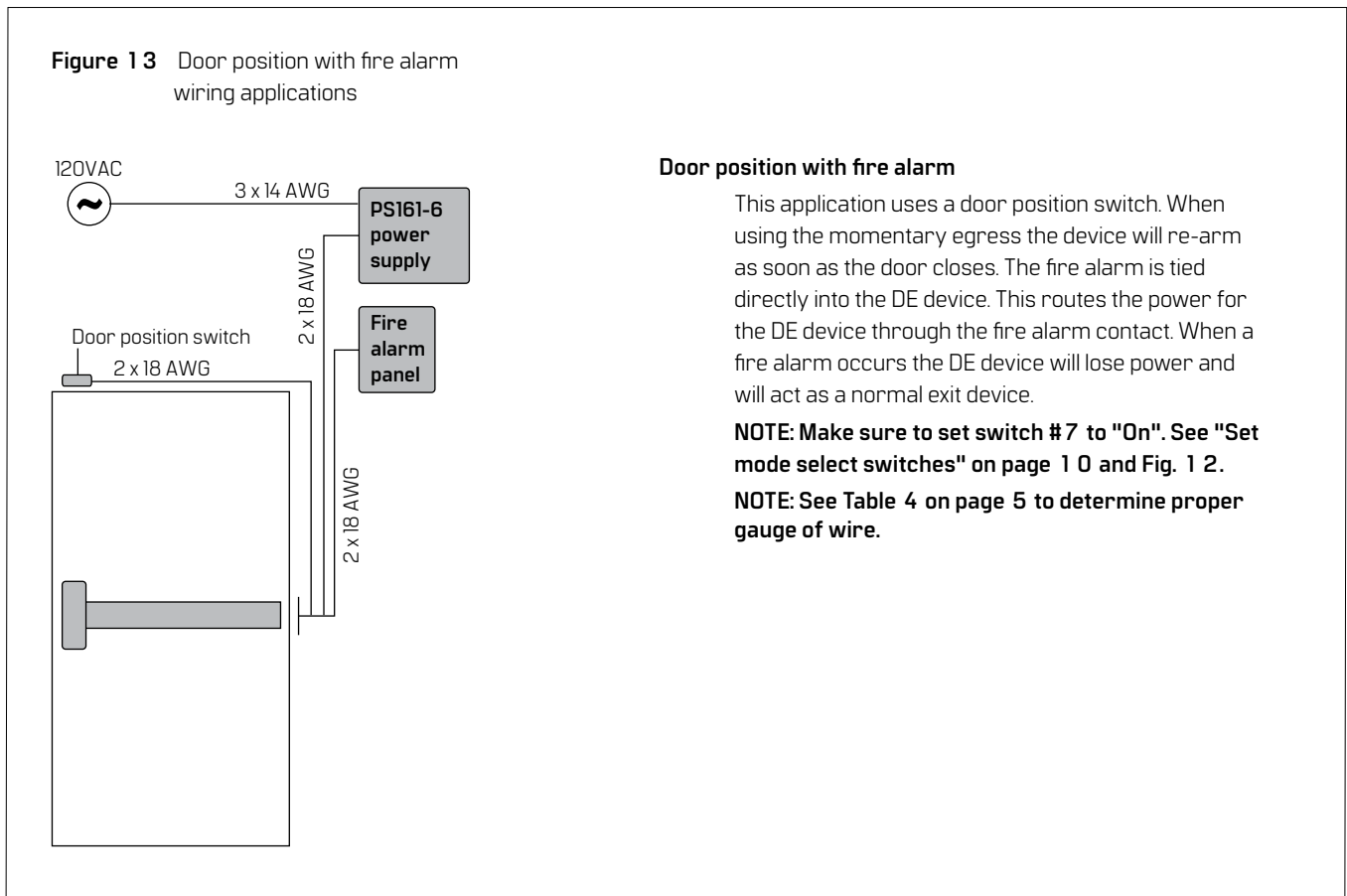

Fig. 1 4, Fig. 1 5

Figure 1 4 Connecting a door position switch and fire alarm panel

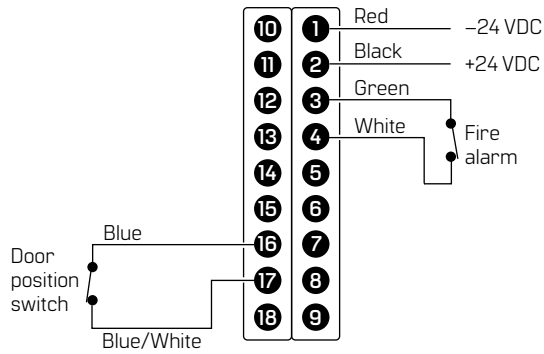

Figure 1 5 Setting DIP switch 7 to "On" to enable door position sensing. (DIP switch 8 is set to "On" as a factory default.)

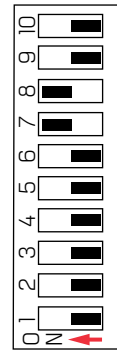
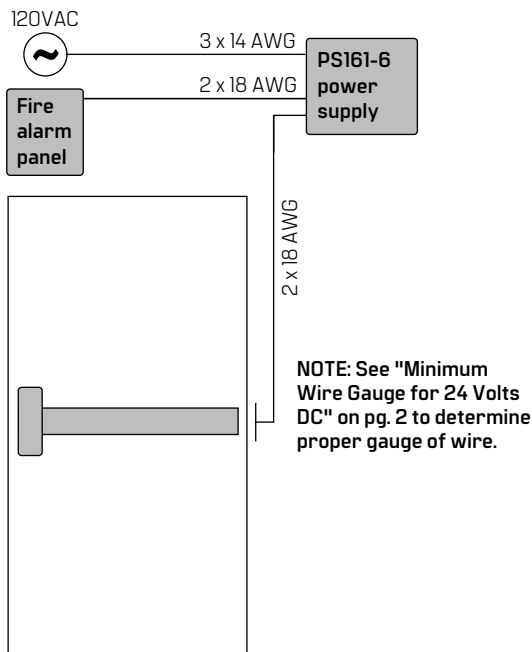

Fig. 1 6, Fig. 1 7

Figure 1 6 Simple DE with fire alarm wiring application



Simple delayed egress with fire alarm

In this basic application, the device will delay egress when armed and function as a normal exit device when disarmed. The 2 4 VDC is supplied through a power transfer, and the fire alarm connection is made at the power supply

Figure 1 7 Connecting power and fire alarm

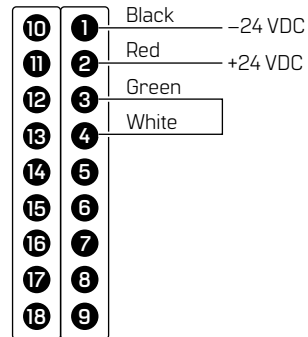
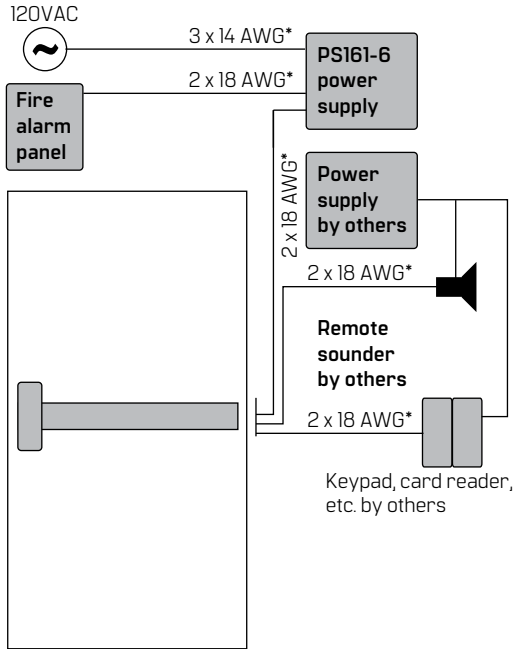

Fig. 18, Fig. 19

Figure 18 Remote arm/disarm and remote monitoring with fire alarm wiring application



Remote arm/disarm and remote monitoring

This application enables remote arm/disarm control and remote monitoring of the delayed egress exit device. When armed, the device will delay egress; when disarmed, it will operate as a normal exit device. The 24 VDC remote switch and horn are powered through a power transfer, and the fire alarm connection is made at the power supply.

NOTE: See Table 4 on page 5 to determine proper gauge of wire.

Figure 19 Connecting a card reader and an alarm output

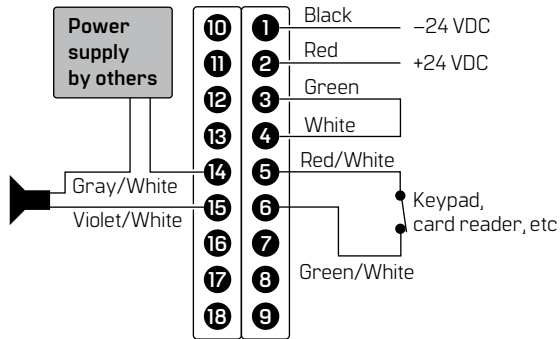

NOTE: External power supply for keypad or card reader is required.

4.1 1 Troubleshooting

Fig. 20, Fig. 21 Fig. 22

Networking two DE devices

This application utilizes the networking feature, ensuring that when one device's alarm sounds, the other device will also activate. The fire alarm connection is made at the power supply.

NOTE: Up to four DE devices can be networked on a single PS 16 1-6 power source.

NOTE: Set switches 1 and 6 to "On". See "Set mode select switches" on page 10 and Fig. 12 for details.

Figure 20 Setting DIP switches 1 and 6 to "On" to enable device networking. Switches 9 and 10 shown are set to number the device. The device on the left is set to zero [0] and the device on the right is set to one [1].

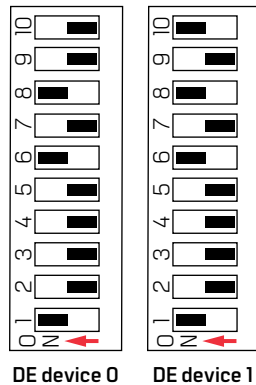

NOTE: See Table 4 on page 5 to determine proper gauge of wire.

Troubleshooting

Refer to Table 8 on following page to help identify and isolate the cause of the problem.

⚠ CAUTION! There are no user-serviceable parts in electronics or locking mechanism. Internal touch bar monitoring switch is factory-set; tampering with this switch may result in device malfunction during an emergency.

NOTICE

Test device periodically to ensure proper operation.

Figure 21 Two DE networked devices with fire alarm wiring application

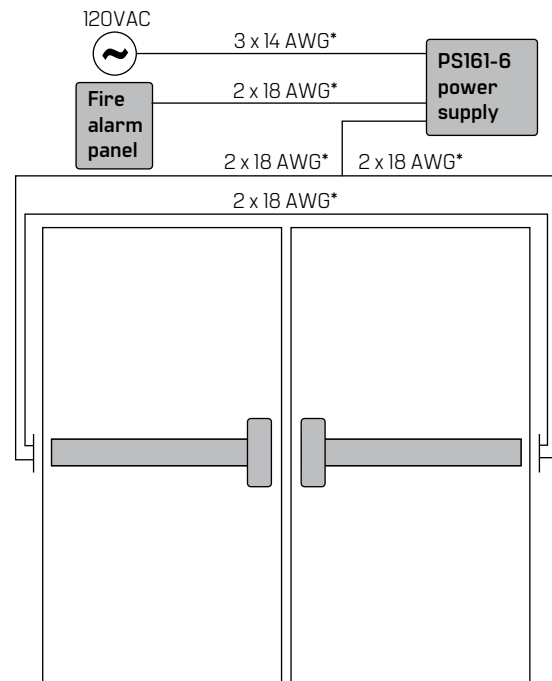

Figure 22 Connecting two DE networked devices with fire alarm

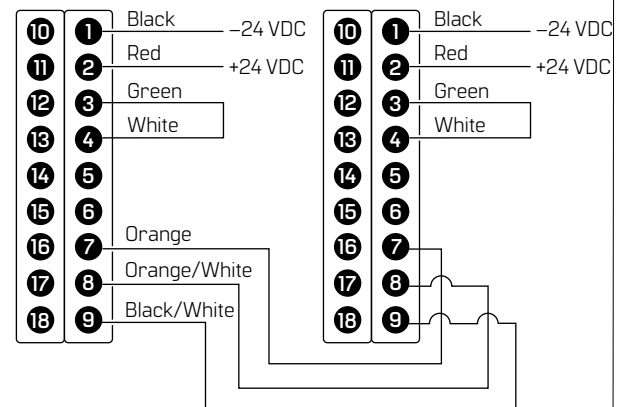

Table 9

Troubleshooting	
Problem	Possible resolutions
No power	<ul style="list-style-type: none"> • Check the circuit breakers. • Check for 120 VAC at the input of the power supply. • Check for 24 VDC at the DE device by placing the probes of a volt meter across the red and black wires. • Check the fire alarm condition: is the fire alarm contact open? The power for the DE device is routed through the fire alarm contacts.
Device will not arm; Touch bar will not lock.	<ul style="list-style-type: none"> • Check for power; LED should be green if the mode select switch 8 is set to "Off". If switch 8 is set to "On", LED should be flashing red. See "LED Indicators" on page 11. • If a door position switch is being used, check for a closed contact across the "Blue" and "Blue/White" wires. • Check for proper position of switch 7. See "Setting the mode select switches" on page 10. • Check the key cylinder for proper installation. See "Install key cylinder" on page 6.
Nuisance delay is not working.	<ul style="list-style-type: none"> • Check for proper position of switch 2 and 3. See "Setting the mode select switches" on page 10. • Check that the proper model DE device is being used. Optional DE devices are configured with the nuisance delay disabled to meet code requirements (BOCA).
Momentary egress time is improper.	<ul style="list-style-type: none"> • The DE device is factory-shipped with the arm/re-arm time set to off. • Check switch 4 and 5. See "Setting the mode select switches" on page 10. • If a door position switch is being used, check for a closed contact across "Blue" and "Blue/White" wires. • Check for proper position of switch 7. See "Setting the mode select switches" on page 10.
Delayed egress time is improper.	<ul style="list-style-type: none"> • Check that the proper model DE device is being used. Optional DE devices are configured with the delayed egress time set to 30 seconds (not 15 seconds).
Device will not reset after alarming.	<ul style="list-style-type: none"> • If a door position switch is being used, check for a closed contact across "Blue" and "Blue/White" wires. • Check for proper position of switch 7. See "Setting the mode select switches" on page 10.



Document translations available.

Scan for product details and downloads.

Call 1-800-392-5209 or visit

<https://dhwsupport.dormakaba.com/hc/en-us>

for assistance and warranty information.

⚠ WARNING! This Manufacturer advises that no lock can provide complete security by itself. This lock may be defeated by forcible or technical means, or evaded by entry elsewhere on the property. No lock can substitute for caution, awareness of your environment, and common sense. Builder's hardware is available in multiple performance grades to suit the application. In order to enhance security and reduce risk, you should consult a qualified locksmith or other security professional.