

ELR Conversion Kit (STD and BF) – ELRK and ELRKF for Wide Stile Devices NELRK and NELRKF for Narrow Stile Devices Installation Instructions

TOOLS NEEDED:

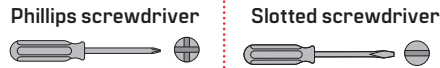

OVERVIEW

CAUTION!
Hand pinch point and sharp edge hazards during install.

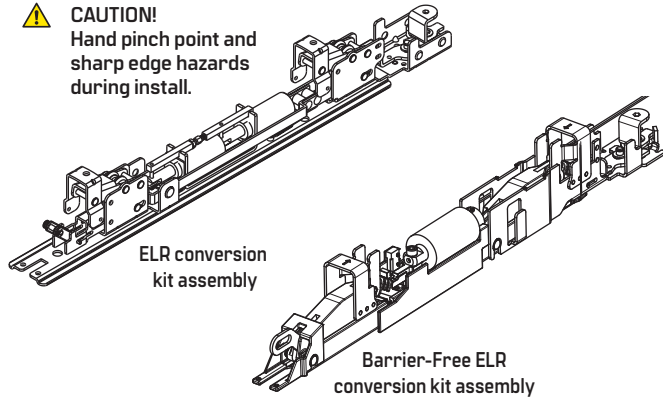

1 REMOVING DEVICE CHANNEL

- 1.1 Remove two screws securing device channel to touchbar mechanism.
- 1.2 Slide device channel with filler plate off touchbar mechanism.

NOTE: Retain device channel with filler plate and screws for use in Step 5.5 – 5.6.

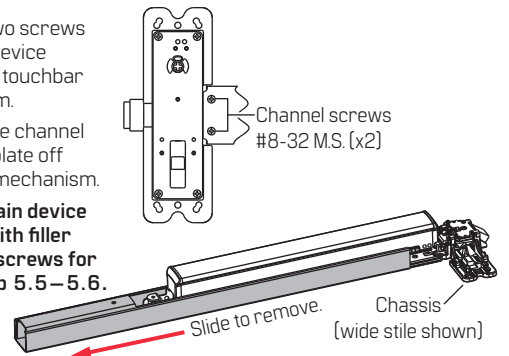

2 REMOVING TOUCHPAD

- 2.1 Remove four screws and, if applicable, four bumpers securing touchpad to touchbar mechanism.
- 2.2 Detach touchpad from touchbar mechanism.
- 2.3 Proceed to "DEVICE CHECK."

NOTE: Retain touchpad, screws and bumpers for use in Step 5.3 – 5.4.

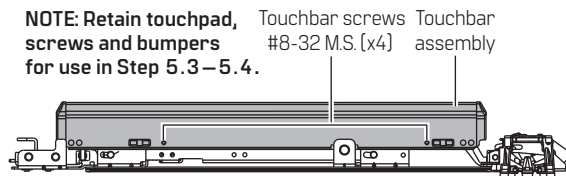

DEVICE CHECK

Standard devices:

- Complete Steps 3–6.

Barrier-free devices:

- Route ELR wire fully through touchbar mechanism, pulling it through until taut.

NOTICE

Do not pinch wires.

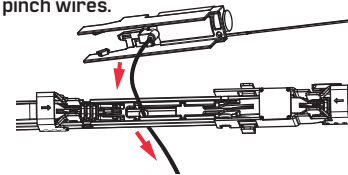

- Position ELR in mounting location within touchbar mechanism, ensuring correct orientation.

3 REMOVING CHASSIS FROM TOUCHBAR MECHANISM

- 3.1 Remove two subplate screws securing chassis to touchbar mechanism.
- 3.2 Detach chassis from touchbar mechanism.

NOTE: Retain subplate screws for use in Step 5.1 – 5.2.

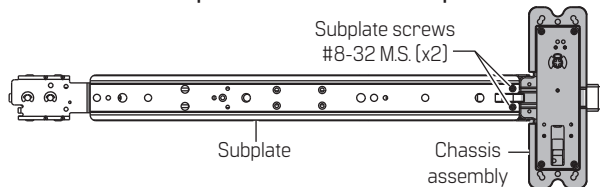

NOTE: Bracket of ELR not shown in illustration.

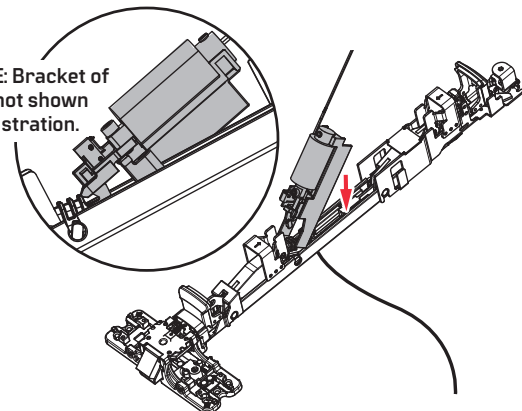

- Press ELR into place until it is fully seated and secure.

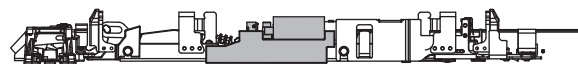

- Complete Steps 5.2–5.6 and Step 6.

4 ADJUSTING

- 4.1 With lever pushed down and solenoid linkage yoke pushed back, yoke assembly must align with pin at end of slot and yoke holes with lever holes.

NOTE: Rotate yoke clockwise on threaded stud to make shorter and counterclockwise to make longer.

- 4.2 Insert link pin into hole and secure it with retaining ring.

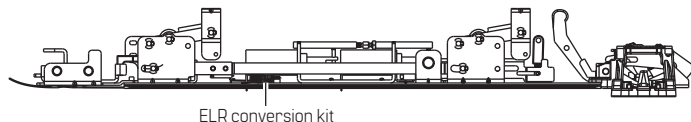

ELR conversion kit

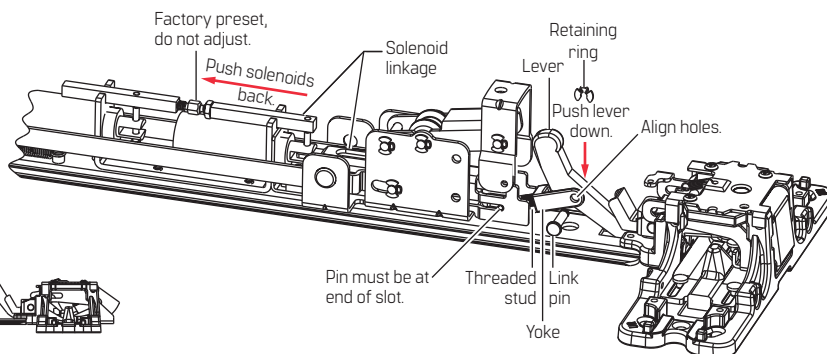

5 REASSEMBLING

- 5.1 Position chassis onto touchbar mechanism.
5.2 Secure chassis to touchbar mechanism using two subplate screws.

NOTE: Use touchbar mechanism or chassis and subplate screws from Step 3.

- 5.3 Attach touchpad to touchbar mechanism, aligning all four screw holes.
5.4 Secure touchpad to touchbar mechanism using four screws and, if applicable, four bumpers.

NOTE: Use touchpad, screws and if applicable bumpers retained from Step 2.

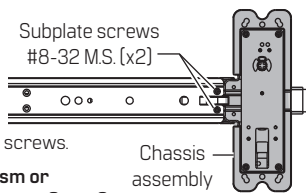

Touchbar screws #8-32 M.S. (x4) Touchbar assembly

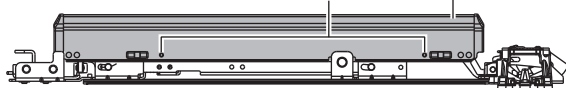

- 5.5 Slide device channel with filler plate onto touchbar mechanism aligning screw holes.

NOTE: Use device channel with filler plate retained from Step 1.

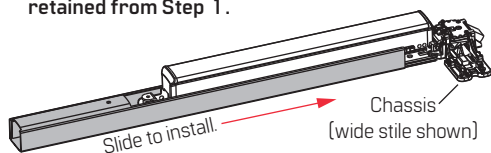

- 5.6 Secure device channel to touchbar mechanism using two screws.

NOTE: Use two screws retained from Step 1.

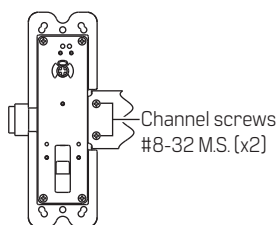

6 ELECTRICAL TESTING

- 6.1 Refer to installation instructions for ELR-I50 power supply (T93666) and CM-I50-08 control module, (T93665). Both must be used with ELR conversion kit.

- 6.2 Device should be bench tested before mounting on door.

Proper Operation:

- Rim device: Upon activating control module, latch bolt should retract and LED 2 on control module should light.
- Vertical rod device: Upon activating control module, rod carriage should lift up approximately 1/2" (12.7) and LED 2 on control module should light.

7 TROUBLESHOOTING

- 7.1 Latch bolt will not retract completely:**
- Adjust yoke by removing link pin and rotating clockwise.
 - Replace link pin and retest.
- 7.2 Rod carriage will not move required 1/2" (12.7):**
- Adjust yoke by removing link pin and rotating clockwise.
 - Replace link pin with retaining ring and retest.
- 7.3 LED 2 will not light when solenoids are energized:**
- Adjust yoke by removing link pin and rotating counterclockwise.
 - Replace link pin and retest.
 - Check for proper wiring. Black wires to TB2-3 and TB2-4 of control module.
- 7.4 Solenoid linkage will not move:**
- Check for proper wiring. White wires to TB2-1 and TB2-2 of control module.
- 7.5 Solenoid linkage will not retract completely:**
- Adjust yoke by removing link pin and rotating counterclockwise.
 - Replace link pin and retest.
- 7.6 Device works on bench, but not on door:**
- Check for shorts, excessive wire runs and open connections.
 - With power off and system completely wired, place probes of an ohm meter on screw heads of TB2-1 and TB2-2. Result should be 4 - 5 ohms.
 - Check device for proper mechanical operation and that vertical rods are properly adjusted.

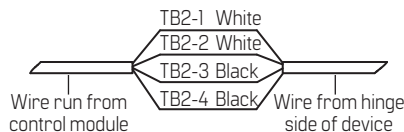

Maximum wire run		
Wire gauge	With 22 gauge power transfer	With 28 gauge power transfer
16	75' [22.86 m]	55' [16.76 m]
14	125' [38.10 m]	75' [22.86 m]
12	200' [60.96 m]	-----



Document translations available.
Scan for product details and downloads.

Call 1-800-392-5209 or visit
<https://dhwsupport.dormakaba.com/hc/en-us>
for assistance and warranty information.

⚠ WARNING! This Manufacturer advises that no lock can provide complete security by itself. This lock may be defeated by forcible or technical means, or evaded by entry elsewhere on the property. No lock can substitute for caution, awareness of your environment, and common sense. Builder's hardware is available in multiple performance grades to suit the application. In order to enhance security and reduce risk, you should consult a qualified locksmith or other security professional.