

**Series: 2100, FL2100 Rim Device – Trim Series: Exit Only, Cylinder Only, 1700, 4900 – Strike: S300, S301, S458 – Wood & Hollow Metal Door Preparation**

For online instructions, assistance or warranty information:  
Call 1-800-392-5209 or visit <https://dhwsupport.dormakaba.com/hc/en-us>

A-hole (4) plcs.	Devices	Trims	B-hole	C-hole
#10-24 tap inside only	2101, FL2101	Exit only	No	No
	2103, FL2103	Cylinder only	1-3/8" [34.93] dia. inside 1-3/16" [30.16] dia. outside	
1/4" [6.35] dia. inside 3/8" [9.53] dia. outside	2101, FL2101	1701, 4901	No	1-3/4" [44.45] dia. through door
	2102, FL2102	1702, 4902		
	2103, FL2103	1703, 4903	1-3/8" [34.93] dia. through door	
	E2103, FLE2103	4908, V4908		
	2105, FL2105	1705		
	2108, FL2108	4908, V4908		
	2110, FL2110			
2114, FL2114	4914	No		
2115, FL2115	1715			

**Reinforcement requirements**

Provide adequate reinforcement to metal-covered composite and hollow metal doors for drilling and tapping for machine screws.

**Sex nuts and bolts**

Sex bolts are required for plastic, wood, metal-covered composite and hollow metal doors without reinforcement.

**Sex bolt machining**

Drill 1/4" [6.35] dia. inside.  
Drill 3/8" [9.53] dia. outside.

**NOTE: "LETTER" at end of trim model number designates lever or grip style. Except as noted, lever or grip style has no effect on stile machining.**

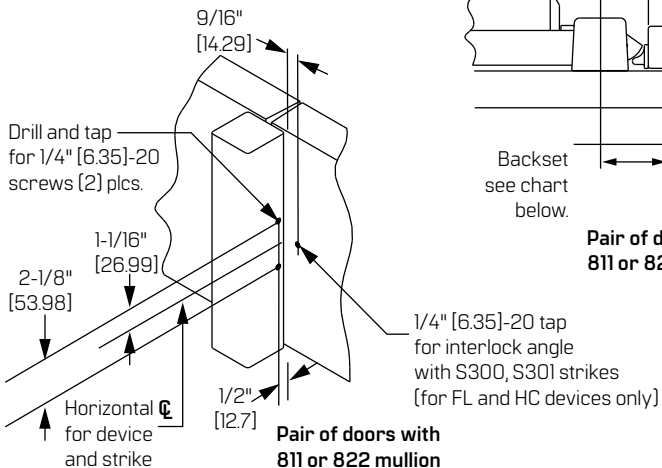
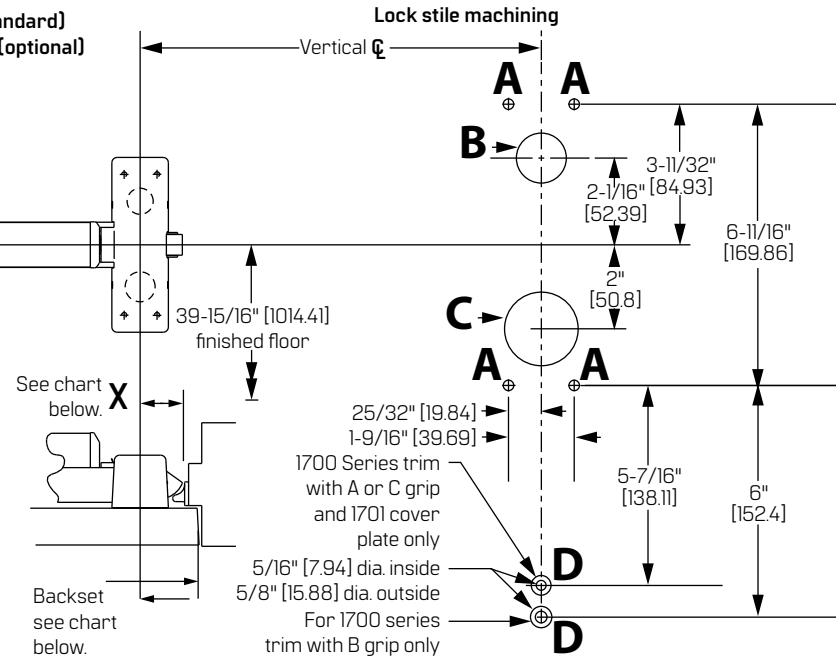
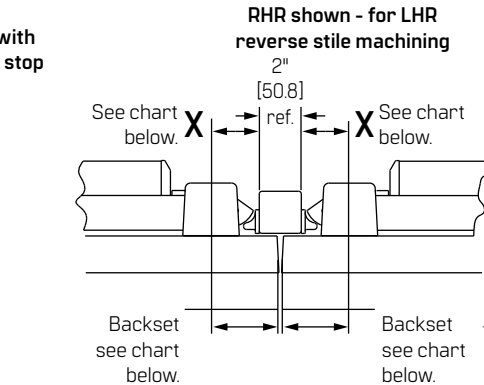
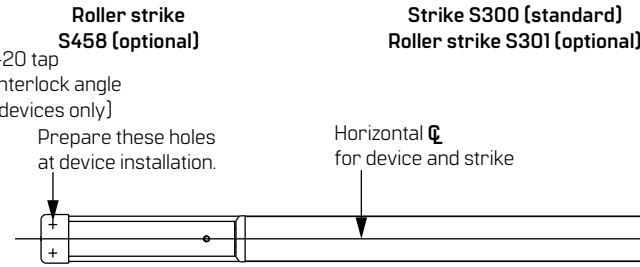
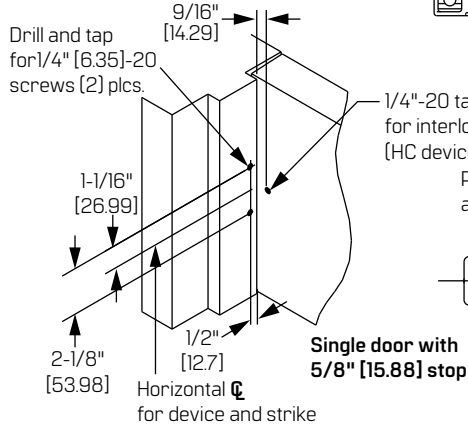
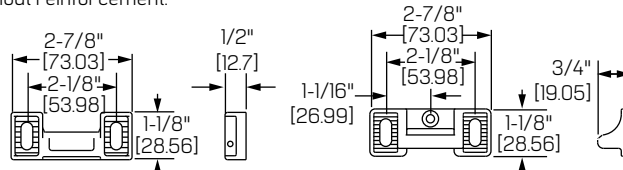

Strike	Application	Backset	Min. stile	"X" dim.
S300 S301	Single door	2-3/4" [69.85]	4-1/4" [107.95]	2-1/4" [57.15]
	Pair of doors	3-1/8" [79.38]	4-5/8" [117.48]	
S 458	Single door	2-9/16" [65.09]	4" [101.60]	2-1/16" [52.39]
	Pair of doors	2-15/16" [74.61]	4-3/8" [111.13]	