

Rim Device 2100 Series x 1700 & 4900 Trim Aluminum Door

Trim Series: Exit Only, CYL Only, 1700, 4900
Device Series: 200
Strike: S988



For online instructions, assistance or warranty information:
Call 1-800-392-5209 or visit <https://dhwsupport.dormakaba.com/hc/en-us>

SEX BOLT MACHINING

DRILL 1/4 DIA. INSIDE
DRILL 3/8 DIA. OUTSIDE

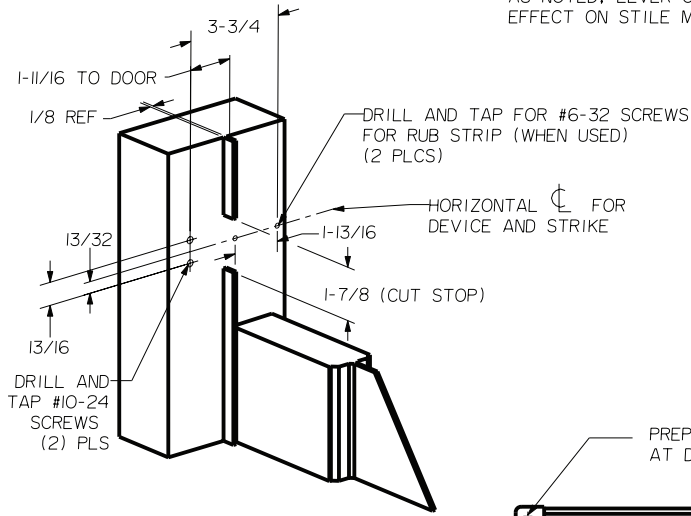

NOTE: "LETTER" AT END OF TRIM MODEL NO. DESIGNATES LEVER OR GRIP STYLE. EXCEPT AS NOTED, LEVER OR GRIP STYLE HAS NO EFFECT ON STILE MACHINING.

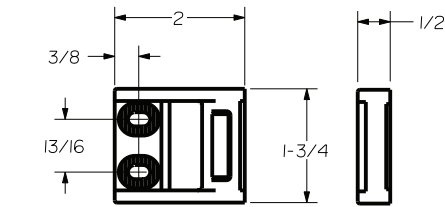

ROLLER STRIKE S988 (STANDARD)

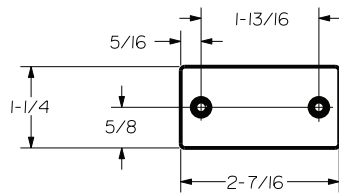

RUB STRIP S454 (STANDARD)

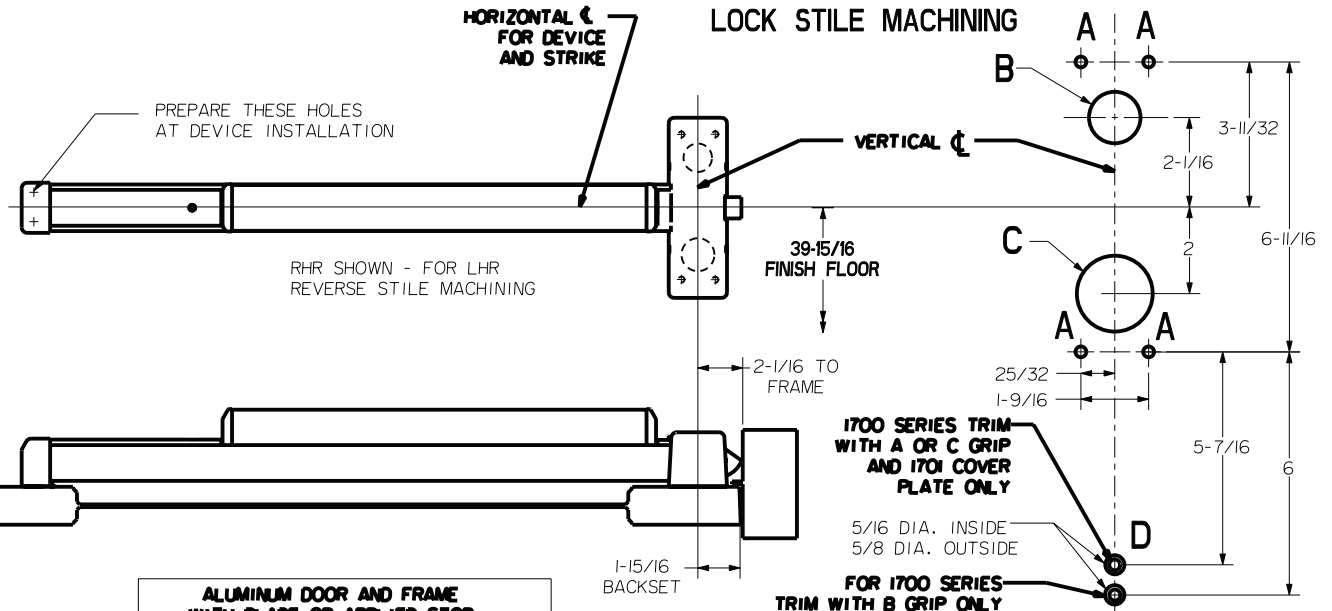
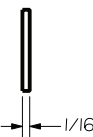

HOLE (4) PLS A	DEVICES	TRIMS	HOLE B	HOLE C
#10-24 TAP INSIDE ONLY	201	EXIT ONLY	NO	NO
	203	CYL ONLY	1-3/8 DIA INSIDE 1-3/16 DIA OUTSIDE	
1/4 DIA INSIDE 3/8 DIA OUTSIDE	201	1701, 4901	NO	1-3/8 DIA THRU DOOR 1-3/4 DIA THRU DOOR
	202	1702, 4902		
	203	1703, 4903		
	E203	4908, V4908		
	205	1705		
	208	4908, V4908		
	210			
214	4914	NO		
215	1715			

ALUMINUM DOOR AND FRAME WITH BLADE OR APPLIED STOP		
MIN. STILES	DEVICE SIZE	DOOR WIDTH
3-1/2"	3'-0"	2'-6" TO 2'-11"
	4'-0"	3'-0" TO 3'-11"
4-1/4 OR FLUSH DOOR	3'-0"	2'-7" TO 3'-0"
	4'-0"	3'-1" TO 4'-0"