

# Series: 2400 Rim Device – Trim Series: 2000 – Strike: S988 – Aluminum Door Preparation

For online instructions, assistance or warranty information:  
Call 1-800-392-5209 or visit <https://dhwsupport.dormakaba.com/hc/en-us>

### Sex bolt machining

Drill 1/4" [6.35] dia. inside  
Drill 3/8" [9.53] dia. outside

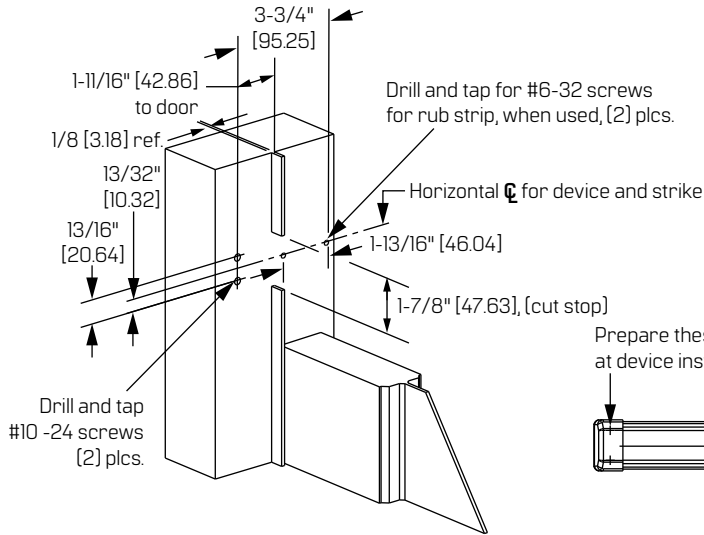

**NOTE: "LETTER" at end of trim model number designates grip style. Except as noted, grip style has no effect on stile machining.**

A-hole (2) plcs.	Devices	Trims	B-hole	C-hole
1/4" [6.35] dia. inside	2401	2001	No	No
13/32" [10.32] dia. outside	2402	2002	No	No
	2403	2003	1-3/8" [34.93] dia outside	5/8" [15.88] dia. inside

### Lock stile machining

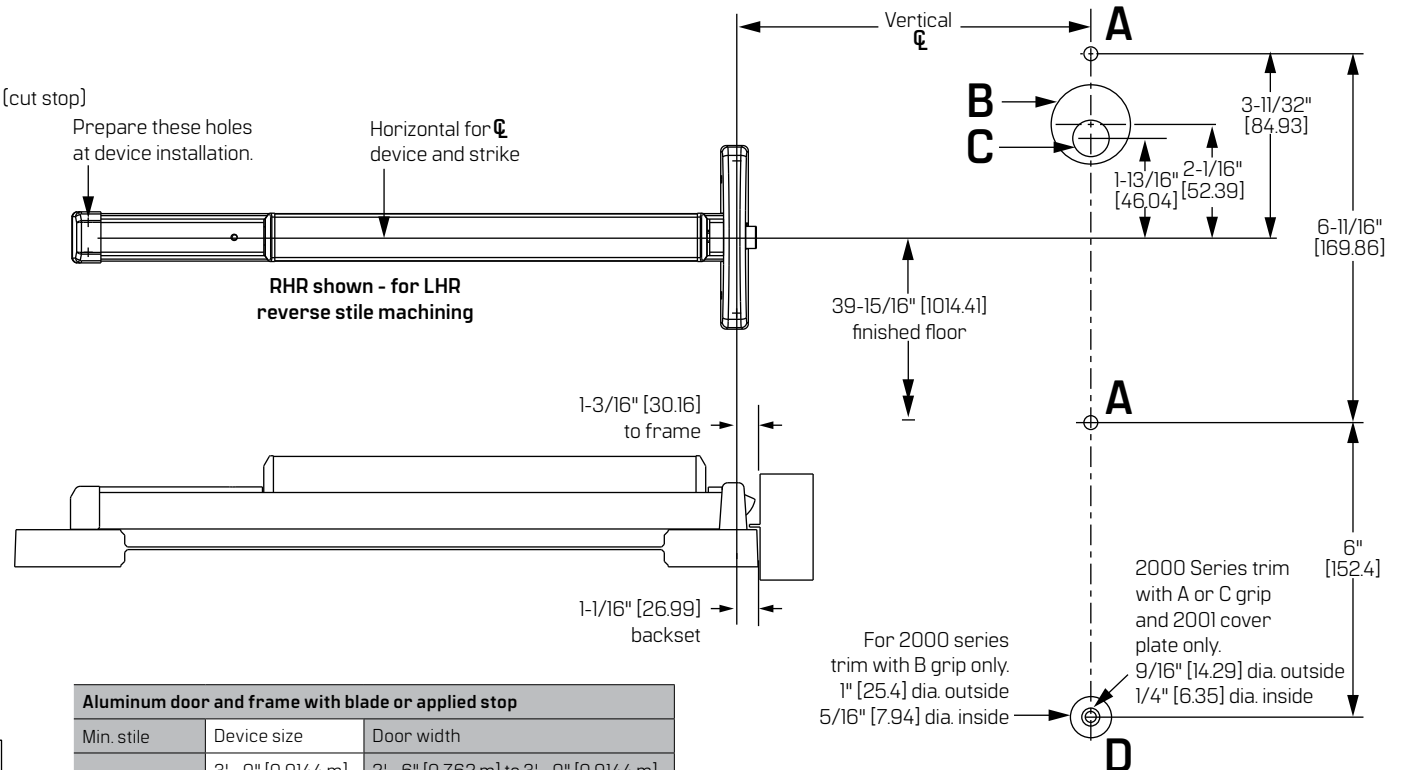

RHR shown - for LHR reverse stile machining

For 2000 series trim with B grip only.  
1" [25.4] dia. outside  
5/16" [7.94] dia. inside

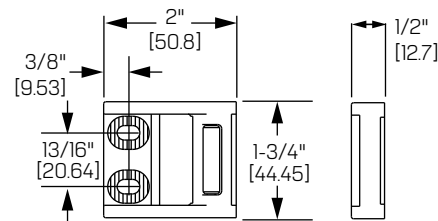

**Roller strike S988 (standard)**

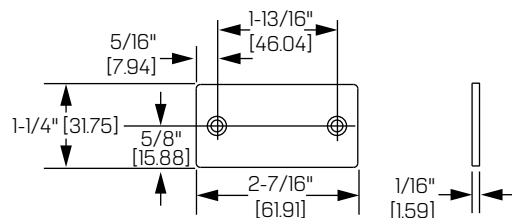

**Rub strip S454 (standard)**

Aluminum door and frame with blade or applied stop		
Min. stile	Device size	Door width
1-3/4" [44.45]	3' - 0" [0.9144 m]	2' - 6" [0.762 m] to 3' - 0" [0.9144 m]
	4' - 0" [1.2192 m]	3' - 1" [0.9398 m] to 4' - 0" [1.2192 m]