

Rim Device 2400 Series x 2908 & 2914 Trim Aluminum Door

Trim Series: 2908, 2914

Device Series: 2400

Strike: S988



For online instructions, assistance or warranty information:
Call 1-800-392-5209 or visit <https://dhwsupport.dormakaba.com/hc/en-us>

SEX BOLT MACHINING

DRILL 1/4 DIA. INSIDE
DRILL 3/8 DIA. OUTSIDE

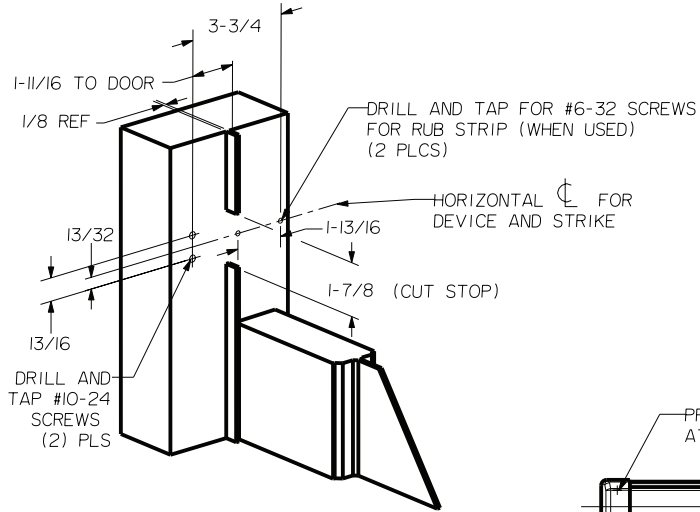

NOTE: "LETTER" AT END OF TRIM MODEL NO. DESIGNATES LEVER STYLE. EXCEPT AS NOTED, LEVER STYLE HAS NO EFFECT ON STILE MACHINING.

DEVICES	TRIMS	HOLE (2) PLS A	HOLE B	HOLE C
2408	2908	1/4 DIA INSIDE 3/32 DIA OUTSIDE	YES	5/8 DIA INSIDE 1-3/8 DIA OUTSIDE
2414	2914		NOT REQ'D	

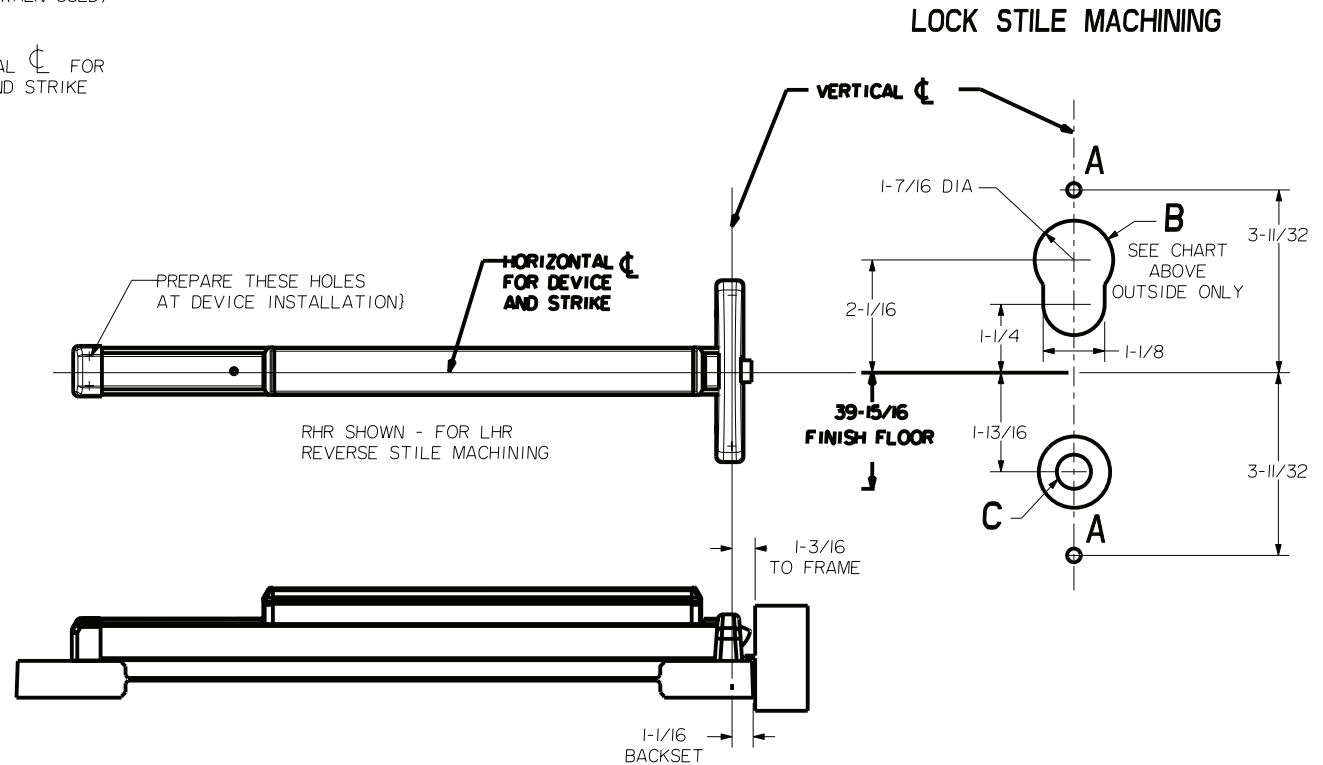
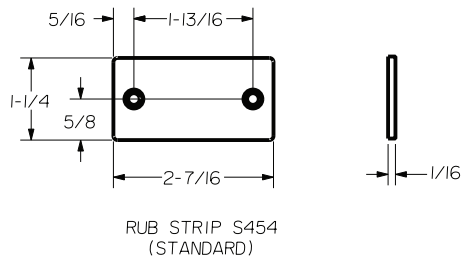
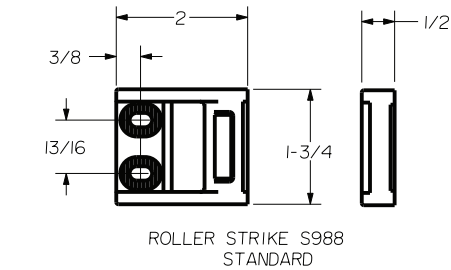

ALUMINUM DOOR AND FRAME WITH BLADE OR APPLIED STOP		
MIN. STILE	DEVICE SIZE	DOOR WIDTH
1-3/4"	3'-0"	2'-6" TO 3'-0"
	4'-0"	3'-1" TO 4'-0"