

Series: 2600, 2600LBR, FL2600, FL2600LBR – Trim Series: Exit Only, Cylinder Only, 2901, 2902, 2903 – Door Preparation

For online instructions, assistance or warranty information:
Call 1-800-392-5209 or visit <https://dhwsupport.dormakaba.com/hc/en-us>

Reinforcement requirements
Provide adequate reinforcement to metal-covered composite and hollow metal doors for drilling and tapping for machine screws.

Sex nuts and bolts
Sex bolts are required for plastic, wood, metal-covered composite and hollow metal doors without reinforcement.

Sex bolt machining
Drill 1/4" [6.35] dia. inside.
Drill 3/8" [9.53] dia. outside.

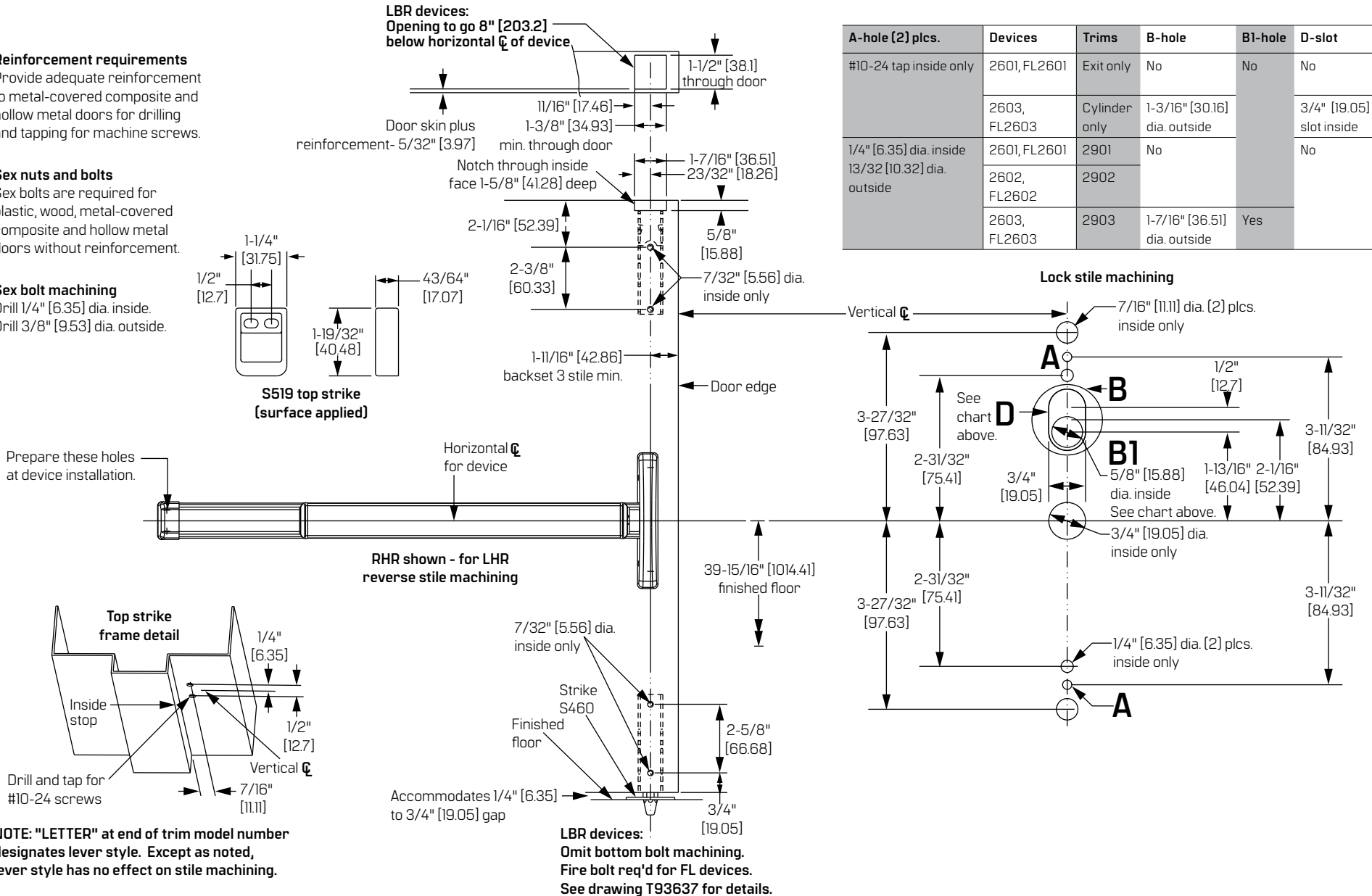

A-hole [2] plcs.	Devices	Trims	B-hole	B1-hole	D-slot
#10-24 tap inside only	2601, FL2601	Exit only	No	No	No
	2603, FL2603	Cylinder only	1-3/16" [30.16] dia. outside		3/4" [19.05] slot inside
1/4" [6.35] dia. inside 13/32 [10.32] dia. outside	2601, FL2601	2901	No		No
	2602, FL2602	2902			
	2603, FL2603	2903	1-7/16" [36.51] dia. outside	Yes	

NOTE: "LETTER" at end of trim model number designates lever style. Except as noted, lever style has no effect on stile machining.