



dormakaba Group

Concealed Vertical Rod Exit Device

Series 2800 | FL2800 | 2800LBR | FL2800LBR (reversible)

Installation Instructions

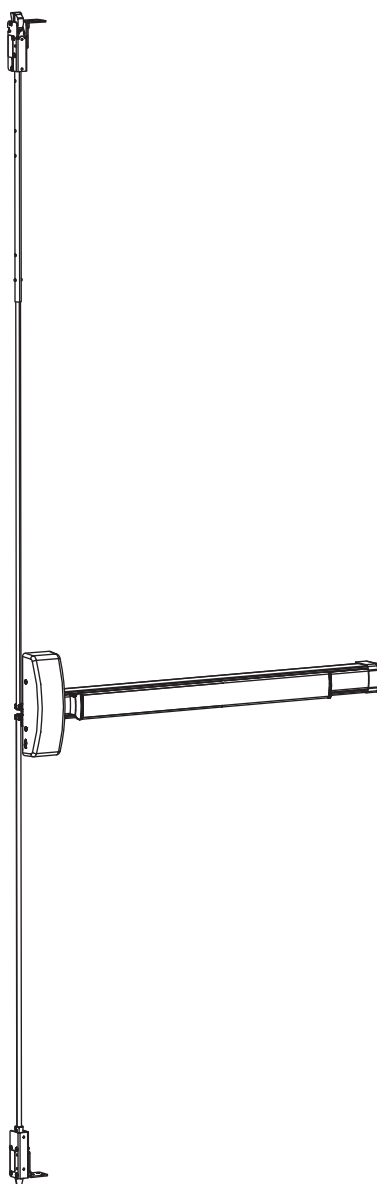

T93626_B - 11/2025

Original document

EN

Table of contents

1	Important safety information	3
1.1	Safety warnings	3
2	Technical specifications	3
2.1	Tools needed	3
2.2	Important information	3
2.3	Measurements	3
2.4	Overview and parts list	4
2.5	Rod height adjustment	5
3	Device preparation	6
3.1	Changing handing (if necessary)	6
3.2	Changing function (if necessary)	7
3.3	Cutting device (if necessary)	7
4	Installation instructions	8
4.1	Prepping door	8
4.2	Installing concealed vertical rod	9
4.3	Installing device	10
4.4	Adjusting deadlock/holdback	11

1 Important safety information

1.1 Safety warnings

- 1.1.1 Safety instructions: To reduce risk of injury or damage, carefully read and follow safety warnings, cautions and notices provided.
- 1.1.2 Safety warnings: Indicates a hazardous situation which, if not avoided, could result in death or serious injury.

 **WARNING**

- 1.1.3 Safety cautions: Indicates a hazardous situation which, if not avoided, could result in minor or moderate injury.

 **CAUTION**

- 1.1.4 Notice: Indicates information considered important but not directly hazard-related.

NOTICE

- Protect inside of device from metal shavings.

2 Technical specifications

2.1 Tools needed

Phillips head screwdriver	Level	Drill bits: 3/32", #25, 7/32", 1/4", 5/16", 3/8", 13/32", 7/16", 5/8", 3/4", 1"	Hacksaw
Flat head screwdriver	Drill	Hole saw: 1-1/8", 1-3/8", 1-7/16", 1-3/4"	Tap: #10-24

2.2 Important information

For fire exit devices series FL2800 and FL2800LBR:

Sex bolts or through bolts are required for composite (wood, plastic and steel covered), wood core, sheet metal and hollow metal doors without reinforcement unless door manufacturer has an alternate mounting method. Fire doors with steel reinforcement, mount devices with machine screws.

NOTE: Fire rated device with less bottom rod applications must use fire bolt.

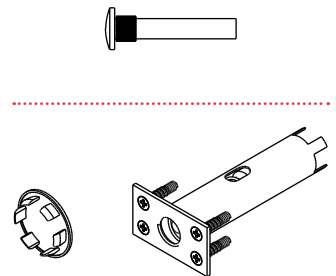

2.3 Measurements

- 2.3.1 All dimensions are given in inches [millimeters].

2.4 Overview and parts list

Fig. 1

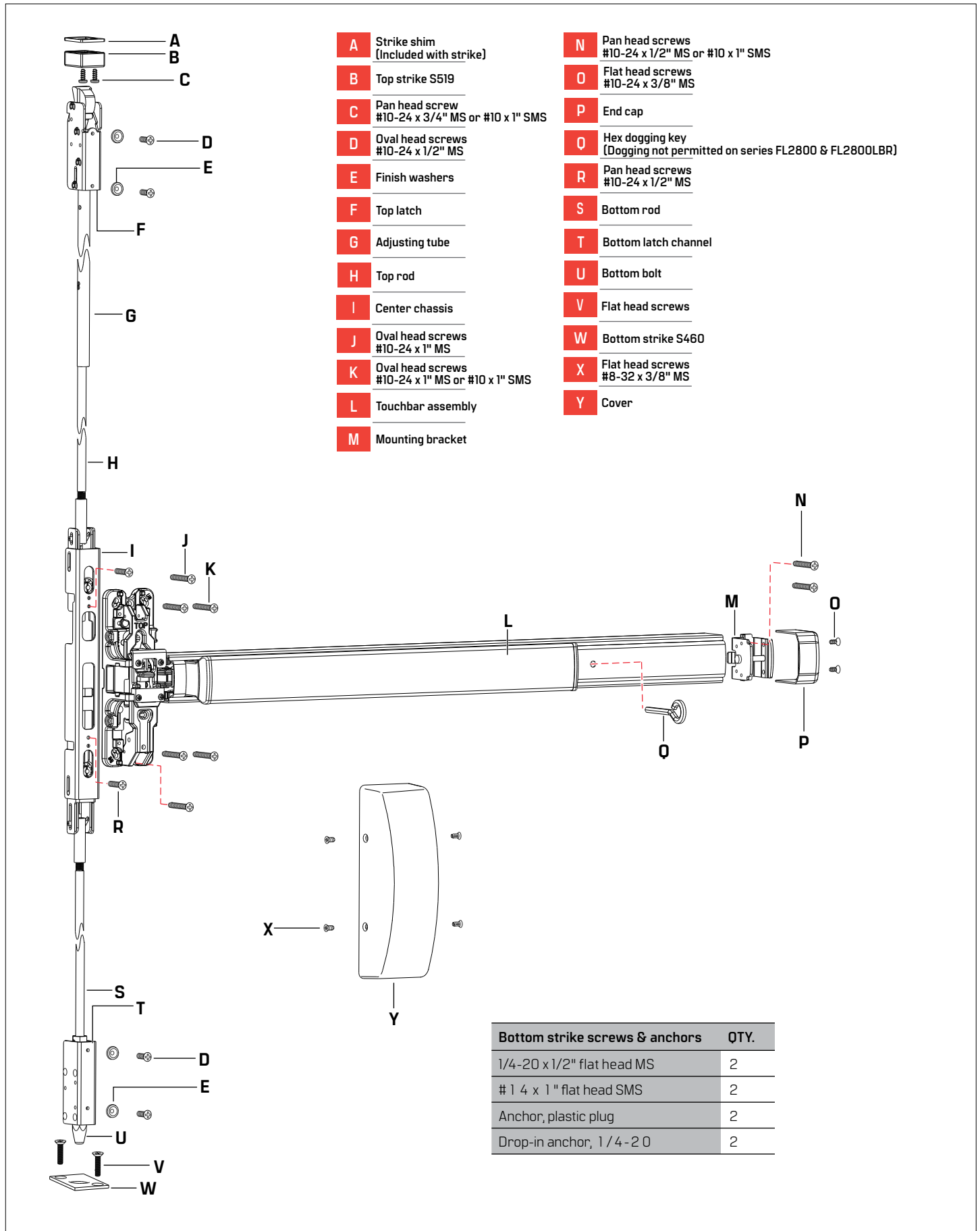

2.5 Rod height adjustment

Fig. 2

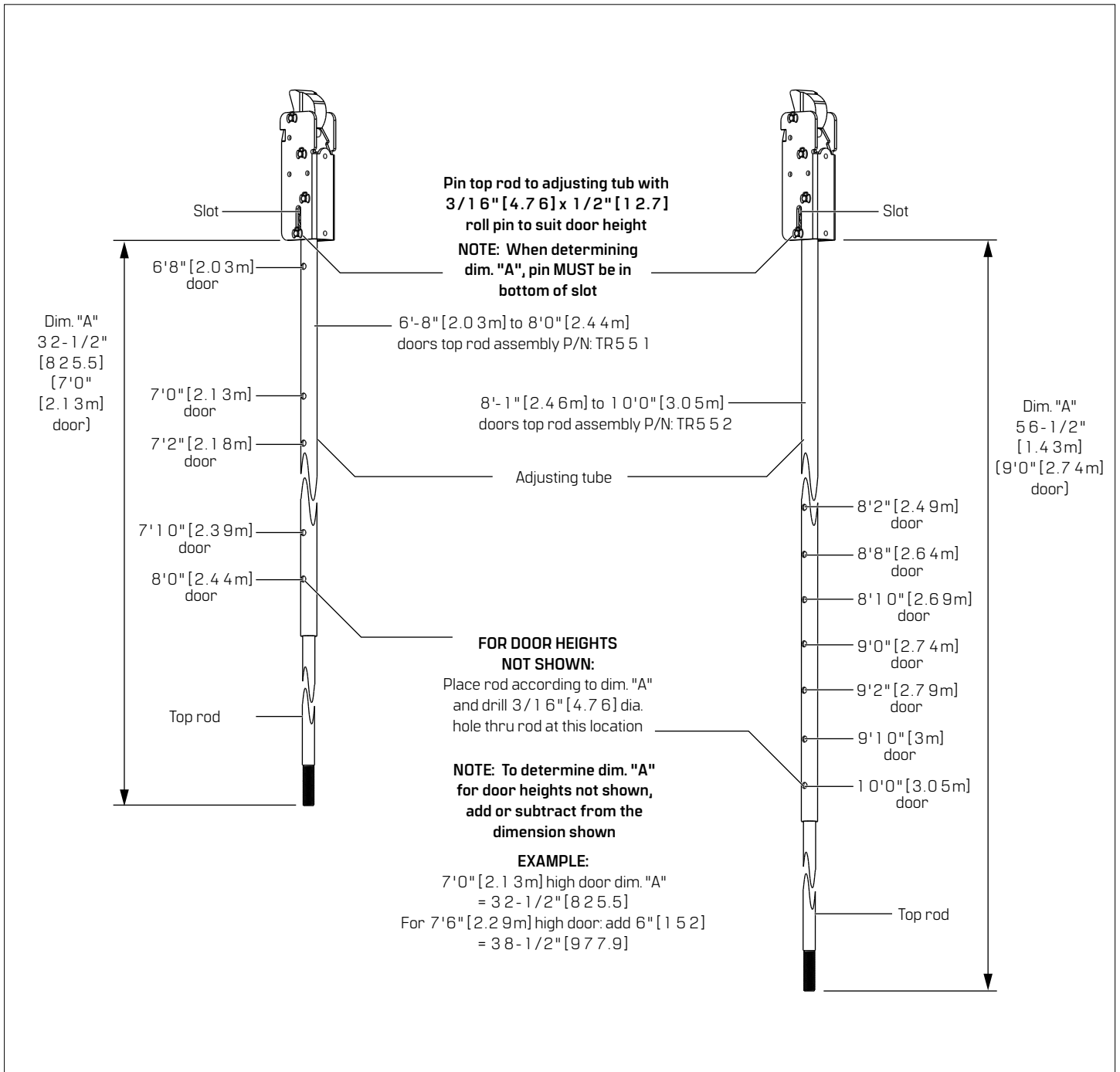

3 Device preparation

3.1 Changing handing (if necessary)

Fig. 3, Fig. 4, Fig. 5

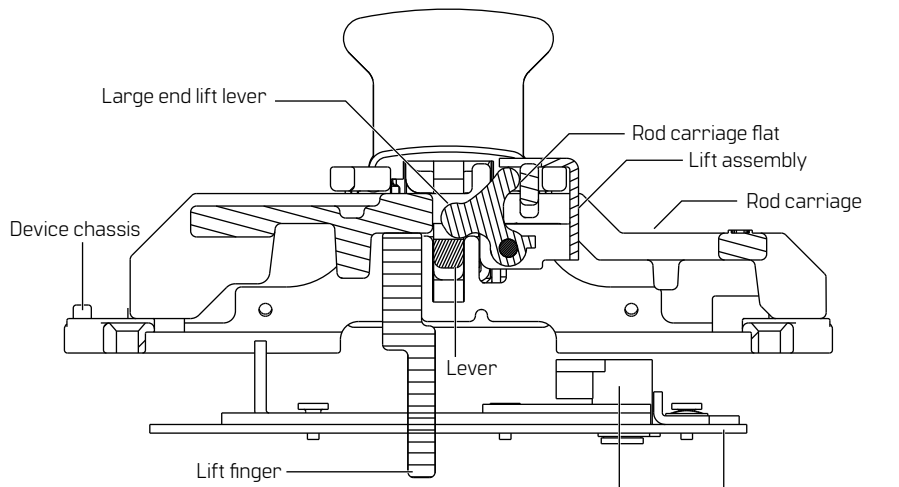

Figure 3 RHRB shown

Cam must be toward TOP marked on rod carriage

Backplate assembly

- 3.1.1 Remove backplate assembly [4 screws].
- 3.1.2 Place device on a bench so device chassis is off edge.
- 3.1.3 Remove lift assembly [2 screws].
- 3.1.4 Slide rod carriage end marked TOP toward lever. Rod carriage will begin to fall, as shown in Fig. 4.

- 3.1.5 Rotate rod carriage until it falls out.
- 3.1.6 Insert bottom end of rod carriage into opposite side of chassis, as shown in Fig. 5.
- 3.1.7 With lever in square hole, rotate rod carriage 90° so it is in same position as step 3.1.4.
- 3.1.8 Push up and slide rod carriage onto chassis.
- 3.1.9 Insert lift assembly into rod carriage, making sure that large end of lift lever is on top of lever and the other end is against rod carriage flat.
- 3.1.10 Attach with two screws.
- 3.1.11 Secure backplate assembly with four screws.

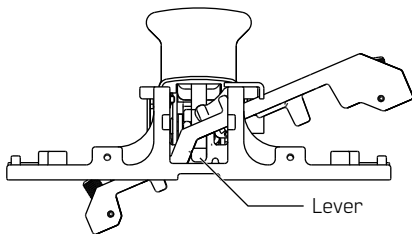

Figure 4 Rod carriage

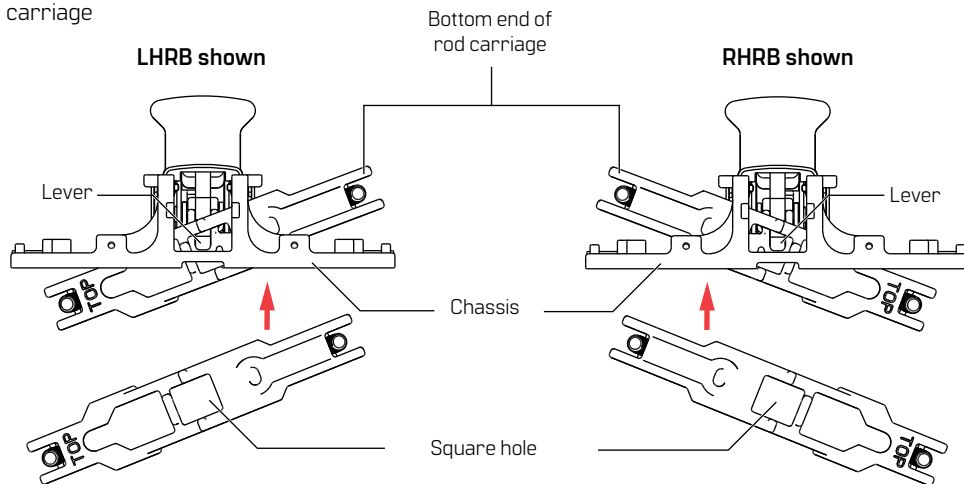

Figure 5 Lift lever

3.2 Changing function (if necessary)

Fig. 6

3.2.1 Remove backplate assembly [4 screws].

3.2.2 Remove cam and rotate 180°.

Figure 6 Cam rotation

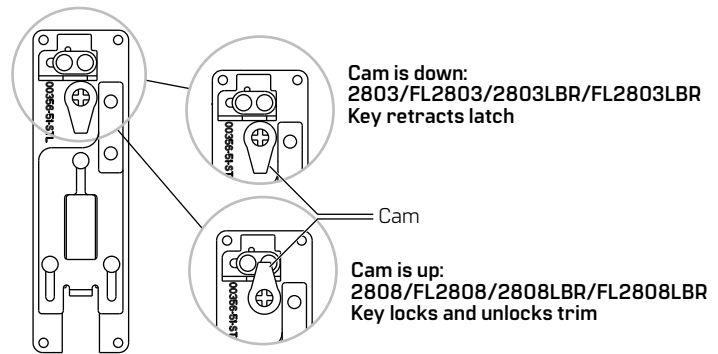

3.3 Cutting device (if necessary)

Fig. 7, Fig. 8

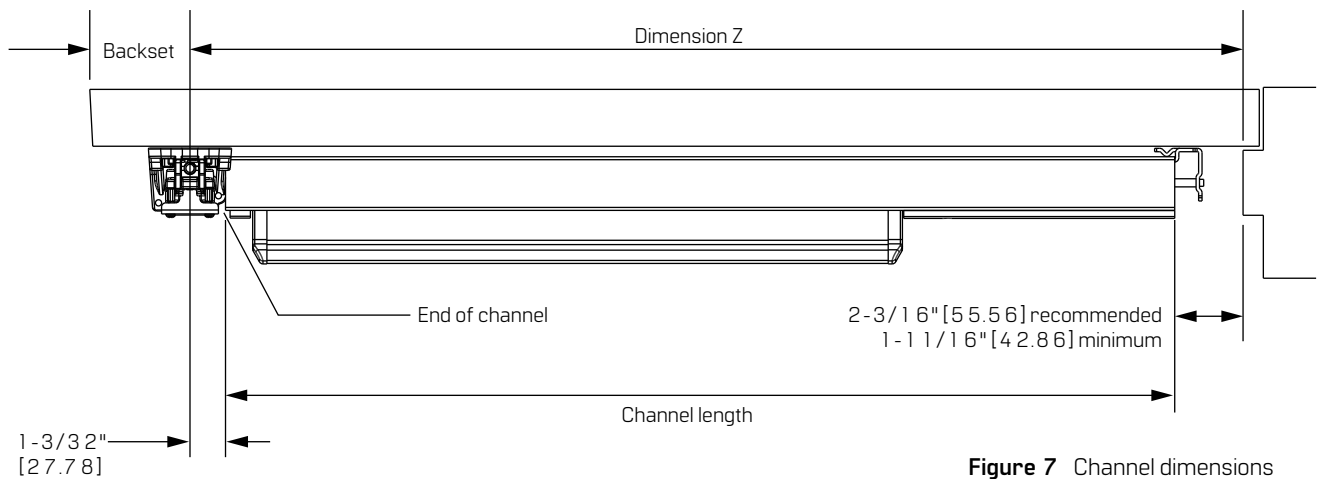

Figure 7 Channel dimensions

3.3.1 Determine proper channel length by subtracting 3-1/4" [82.55] from dimension Z.

3.3.2 Mark cut-off point.

NOTE: Hinge side filler must be all the way inside of channel.

3.3.3 Cut off channel and hinge side filler and deburr.

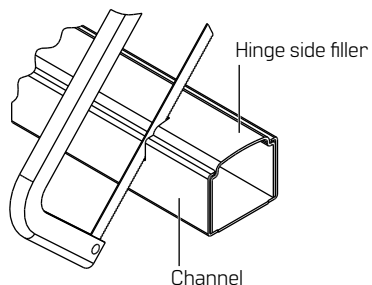

Figure 8 Cutting device

NOTICE

Protect inside of device from metal shavings.

NOTICE

If device is equipped with ALK, CD, DE, or DS refer to instruction sheet listed below prior to cutting device.

ALK	Alarm kit	T93642
CD	Cylinder dogging	T93616
DE	Delayed egress	T93654
DS	Door position	T93668

4 Installation instructions

4.1 Prepping door

Fig. 9, Fig. 10

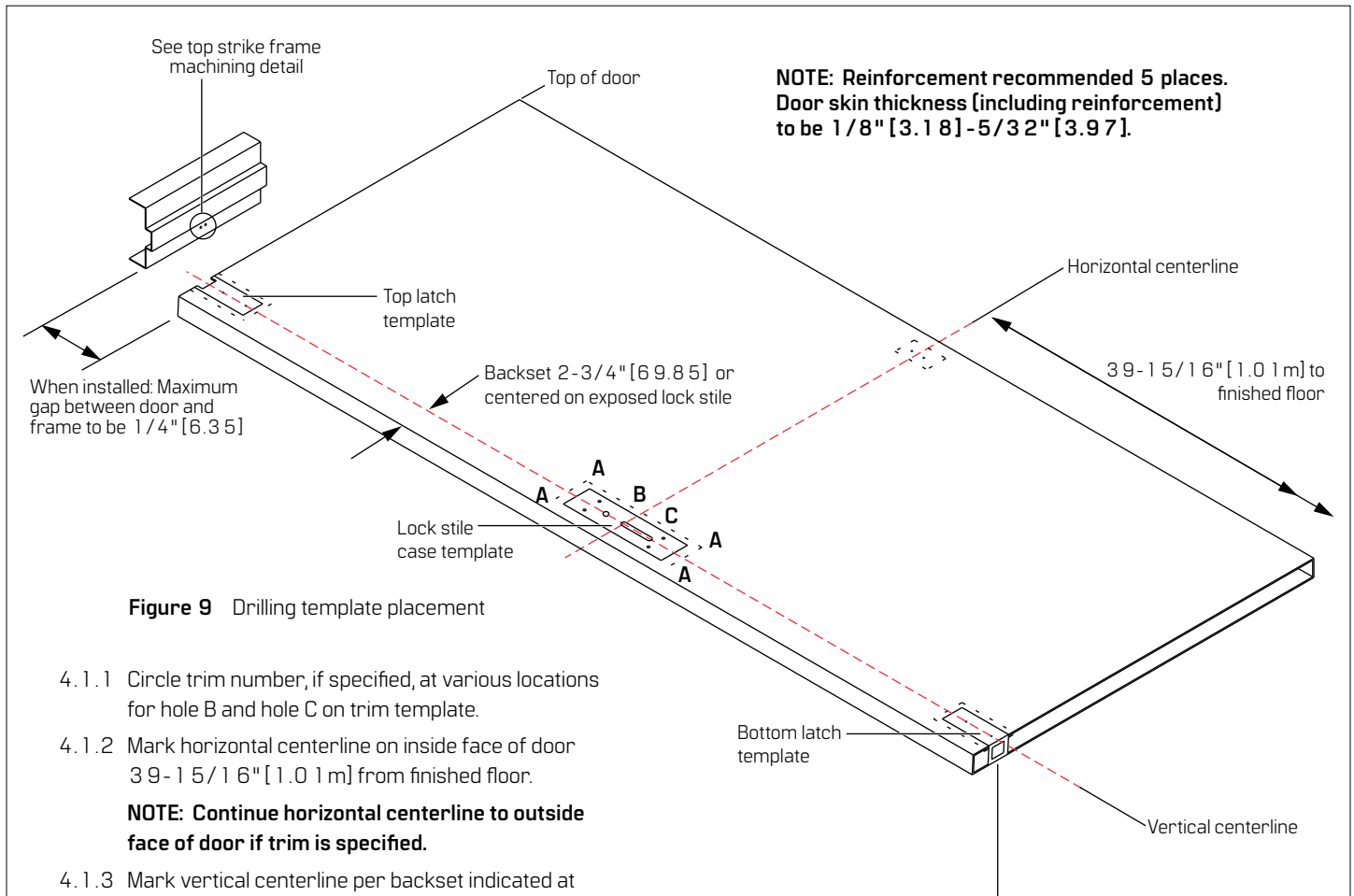

Figure 9 Drilling template placement

- 4.1.1 Circle trim number, if specified, at various locations for hole B and hole C on trim template.
- 4.1.2 Mark horizontal centerline on inside face of door 39-15/16" [1.01 m] from finished floor.

NOTE: Continue horizontal centerline to outside face of door if trim is specified.

- 4.1.3 Mark vertical centerline per backset indicated at lock side on full height of door and carry it onto underside of door stop.

NOTE: If trim is specified, mark vertical centerline at lock side using backset dimension on outside face of door.

NOTE: Vertical centerlines on both sides of door should be same dimension from edge of door.

NOTICE

For LBR device, omit prep for bottom latch. For FL2800LBR devices, see fire bolt installation sheet T93638.

- 4.1.4 Tape lock stile case, top latch and bottom latch templates, and trim template if trim specified, to door so that centerlines on templates line up with centerlines on door.
- 4.1.5 Mark centers and drill required holes as indicated on templates.

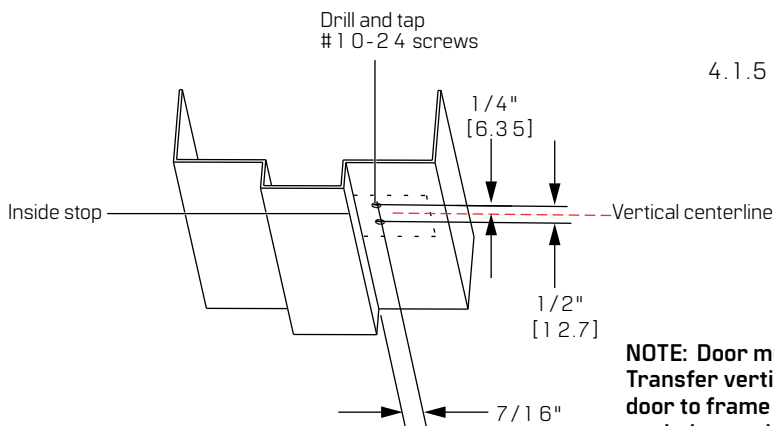

Figure 10 Top strike machining

4.2 Installing concealed vertical rod

Fig. 1 1, Fig. 1 2

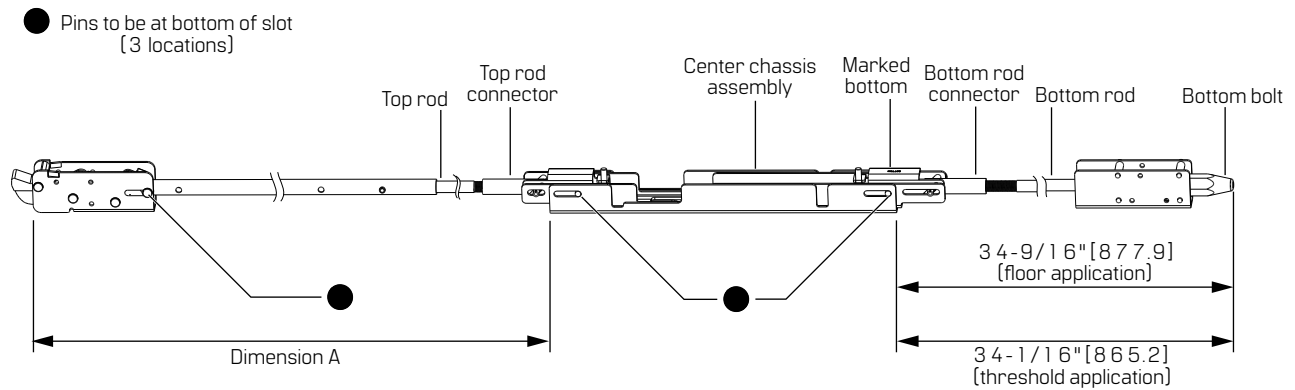

Figure 1 1 CVR assembly

- 4.2.1 Thread top rod onto top rod connector to dim. "A", as shown in table below.

Door height	Dim. "A"
7'-0" [2.13m]	37-1 1/16" [957.26]
8'-0" [2.44m]	49-1 1/16" [1.26m]
9'-0" [2.74m]	61-1 1/16" [1.57m]
10'-0" [3.05m]	73-1 1/16" [1.86m]

NOTE: For door heights not shown, add or subtract from dim. "A" shown.

- 4.2.3 Insert concealed vertical rod (CVR) assembly into door through hole in top edge of door.
- 4.2.4 Attach center chassis to door with two screws through "E" holes.
- 4.2.5 Attach each latch to door with two screws and finishing washers.

NOTE: All dimensions are based on horizontal centerline of device being mounted 39-1 5/16" [1.01 m] from finished floor. Adjust dimensions shown when device is not mounted at that height.

- 4.2.2 Thread bottom rod onto bottom rod connector to the required dimension.

NOTE: Bottom bolt must be fully extended.

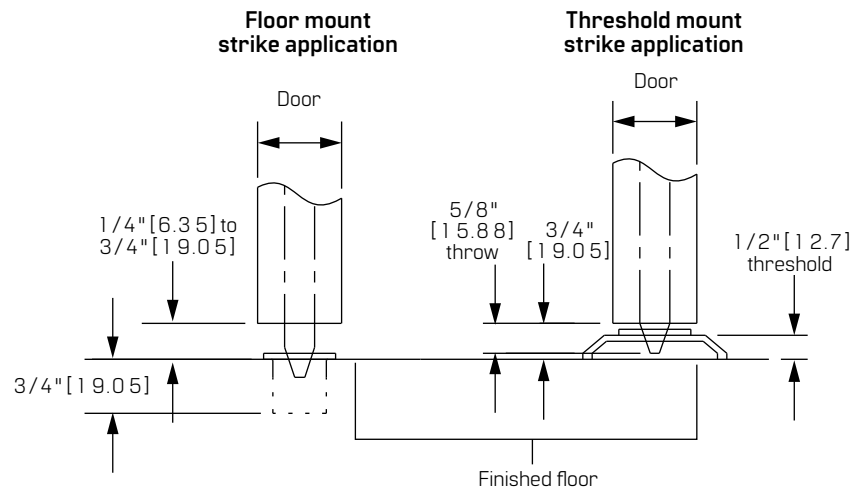

Figure 1 2 Bottom bolt application

4.3 Installing device

Fig. 1 3, Fig. 1 4

NOTE: If trim is specified, see trim installation instructions packaged with trim. If exit device has electrical or other options, see specific option instructions packaged in exit device carton.

- 4.3.1 Lock stile case mounting:
 - **Device with trim:** See trim instructions.
 - **Cylinder only:** See 03 trim instructions.
- 4.3.2 Insert mounting bracket into touch bar assembly tight against channel.
- 4.3.3 Level device, mark and drill two holes for # 1 0 sheet metal screws or # 1 0-2 4 machine screws.
- 4.3.4 Fasten mounting bracket to door and attach endcap with two flat head screws.
- 4.3.5 Attach top strike to frame using two screws.

NOTE: If there is an excessive clearance between door and frame, apply strike shim.

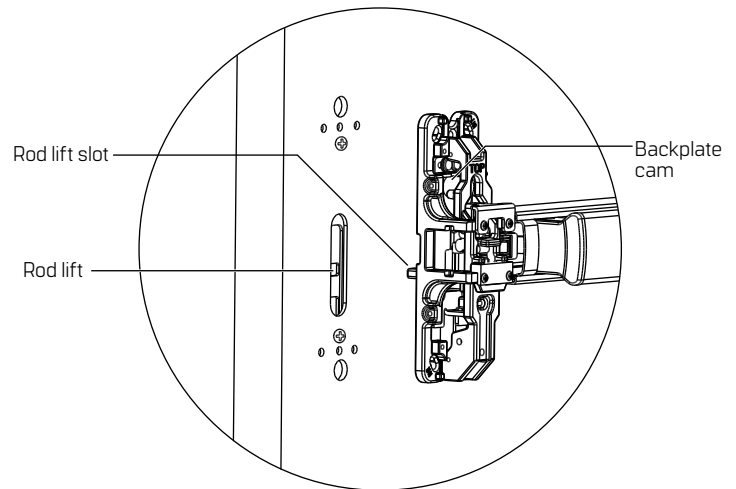

Figure 1 3 Device placement

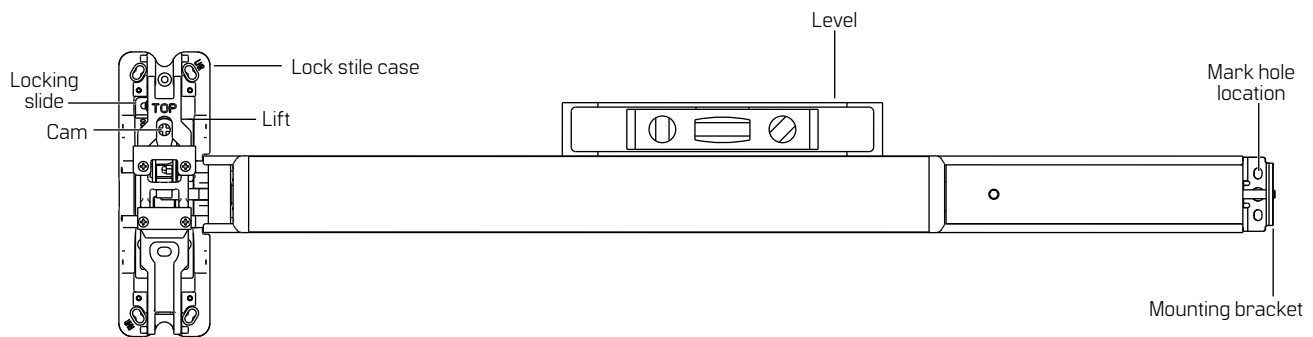

Figure 1 4 Mounting device

NOTICE

For C1715 and 4914 trim, lift must be unlocked. Cam will move locking slide away from lift to unlock.

- 4.3.6 Apply bottom strike:
 - **For floor application:** Center strike around bolt. Mark floor for fasteners. Prepare floor for type of fastener furnished. Provide clearance in floor for bolt.
 - **For threshold application:** Center strike around bolt. Provide hole in threshold to accept bolt. Mark threshold for fasteners. Prepare threshold according to type of fasteners provided.
- 4.3.7 Attach cover to lock stile chassis with four screws.

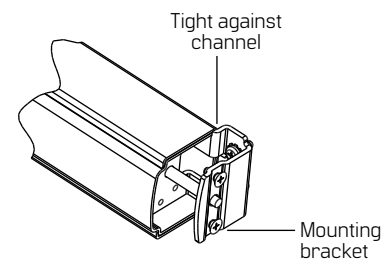

Figure 1 3 Mounting bracket

4.4 Adjusting deadlock/holdback

Fig. 1 5

Deadlock

When latchbolt is fully extended, it should be in deadlock. Deadlocking does not allow latchbolt to be pushed down.

- 4.4.1 Rotate top latchbolt to extend fully.
- 4.4.2 If not deadlocked, turn top adjusting screw counter clockwise one half turn and repeat if necessary.

HOW TO ADJUST BOTTOM BOLT

- 4.4.3 Depress touch bar.

NOTE: Device must be in holdback to gain access to adjusting screw.

- 4.4.4 To increase clearance between bottom bolt and strike, turn bottom adjusting screw clockwise.
- 4.4.5 To decrease clearance between bottom bolt and strike, turn bottom adjusting screw counter clockwise.

Holdback

Top latch should be in holdback when touchbar is depressed and door is open. If not in holdback, latchbolt cannot be extended without rotating latchbolt. Be sure bottom bolt clears bottom strike.

- 4.4.1 Turn top adjusting screws clockwise one half turn and repeat if necessary.

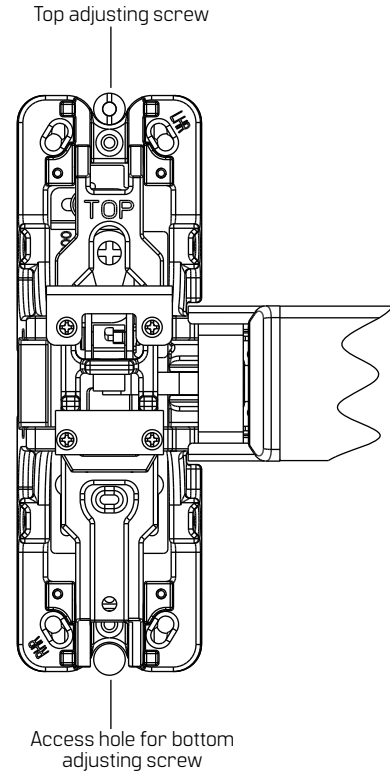

Figure 1 5 Adjustment screws



Document translations available.
Scan for product details and downloads.
Call 1-800-392-5209 or visit
<https://dhwsupport.dormakaba.com/hc/en-us>
for assistance and warranty information.

⚠ WARNING! This Manufacturer advises that no lock can provide complete security by itself. This lock may be defeated by forcible or technical means, or evaded by entry elsewhere on the property. No lock can substitute for caution, awareness of your environment, and common sense. Builder's hardware is available in multiple performance grades to suit the application. In order to enhance security and reduce risk, you should consult a qualified locksmith or other security professional.