

Series: 2300, FL2300 – Trim Series: Exit Only, Cylinder Only, 1700, 4900 – Door Preparation

For online instructions, assistance or warranty information:
Call 1-800-392-5209 or visit <https://dhwsupport.dormakaba.com/hc/en-us>

Reinforcement requirements
Provide adequate reinforcement to metal-covered composite and hollow metal doors for drilling and tapping for machine screws.

Sex nuts and bolts
Sex bolts are required for plastic, wood, metal-covered composite and hollow metal doors without reinforcement.

Sex bolt machining
Drill 1/4" [6.35] dia. inside.
Drill 3/8" [9.53] dia. outside.

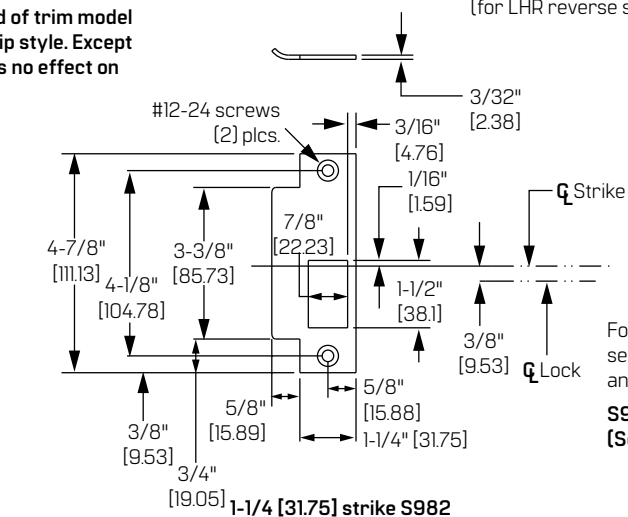
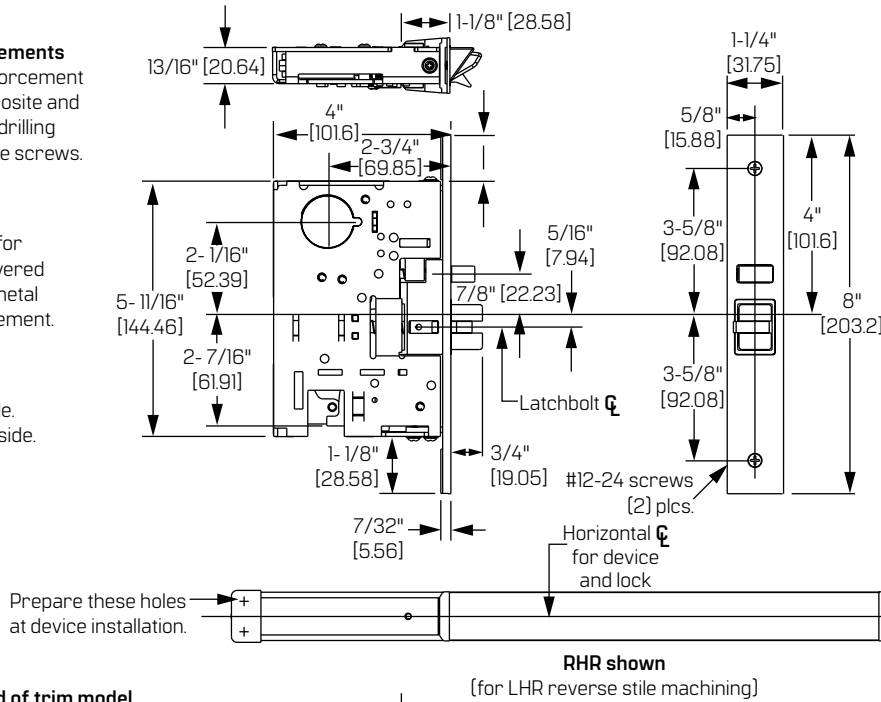

NOTE: "LETTER" at end of trim model number designates grip style. Except as noted, grip style has no effect on stile machining.

For electric connections, see Wire Chase Locations and Dimensions, T93671.

S985, S984 optional open back strikes (See template number T93543.)

Devices	Trims	B-hole 1-3/8" [34.93] dia. through door	C slot	D1
2301, FL2301	2001	No	Inside only	3/8" [9.53] dia. outside 1/4" [6.35] dia. inside
2302, FL2302	2002	No		
2303, FL2303	2003	Yes	Through door	No
2305, FL2305	M2005	No		
2315, FL2315	M2015	No		

