

# Series: 2300, FL2300 – Trim Series: Exit Only, Cylinder Only, 1700, 4900 – Door Preparation

For online instructions, assistance or warranty information:  
Call 1-800-392-5209 or visit <https://dhwsupport.dormakaba.com/hc/en-us>

**Reinforcement requirements**  
Provide adequate reinforcement to metal-covered composite and hollow metal doors for drilling and tapping for machine screws.

**Sex nuts and bolts**  
Sex bolts are required for plastic, wood, metal-covered composite and hollow metal doors without reinforcement.

**Sex bolt machining**  
Drill 1/4" [6.35] dia. inside.  
Drill 3/8" [9.53] dia. outside.

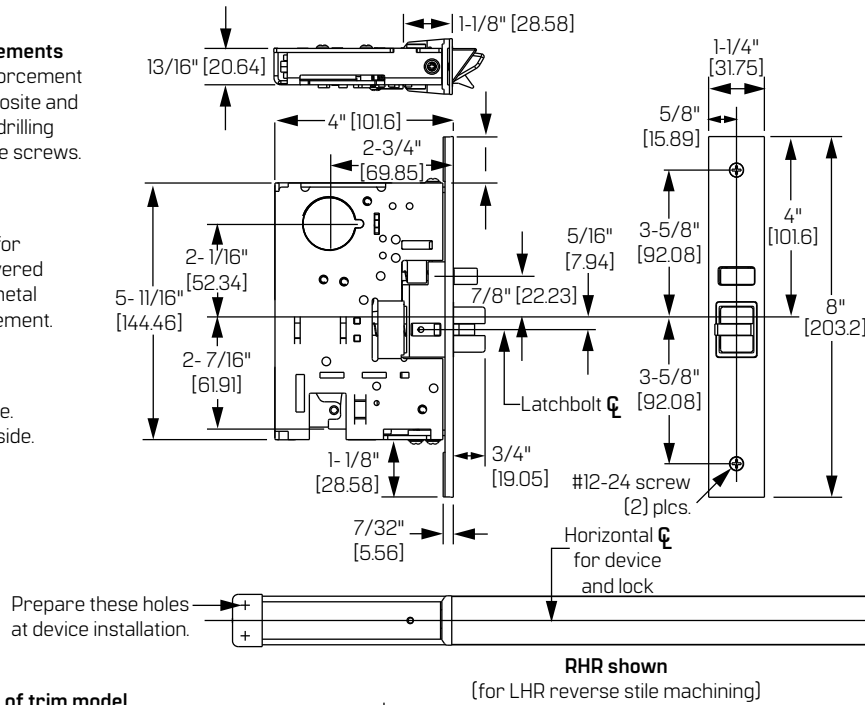

A-hole [4] plcs.	Devices	Trims	B-hole	C-hole
# 10-24 tap inside only	2301, FL2301	Exit only	No	Slot inside only
1/4" [6.35] dia. inside 3/8" [9.53] dia. outside	2303, FL2303	Cylinder only	1-3/16" [30.16] dia. outside	Slot through door
	2301, FL2301	1701, 4901	No	
	2302, FL2302	1702, 4902	No	
	2303, FL2303	1703, M4903	1-3/8" [34.93] dia. outside only	
	E2303, FLE2303	M4908, VM4908		
	2305, FL2305	M1705		
	2308, FL2308	M4908, MV4908		
	2310, FL2310		1-3/8" [34.93] dia. through door	
	2314, FL2314	M4914	No	
	2315, FL2315	M1715		

**NOTE: "LETTER" at end of trim model number designates lever or grip style. Except as noted, lever or grip style has no effect on stile machining.**

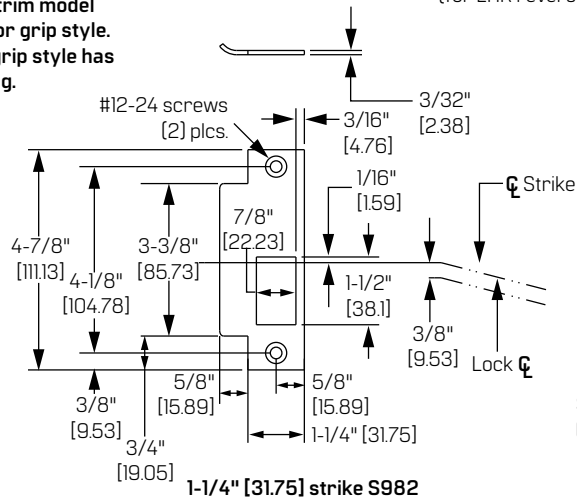

**S985, S984 optional open back strikes**  
(See template number T93543.)

