

For online instructions, assistance or warranty information:
Call 1-800-392-5209 or visit <https://dhwsupport.dormakaba.com/hc/en-us>

ARM-A-DOR™

NOTE: The alarm sub-assembly, part number A103-003, can be installed on all ARM-A-DOR™ models using these instructions. On alarmed models, disarm the alarm prior to installation.

INSTALLATION/REPLACEMENT INSTRUCTIONS

1. Remove the four screws and the end cap on the end of the unit near the key/cylinder as shown in Figure 1. On models manufactured before March 15, 2001, disconnect the batteries by unplugging the white connector.
2. Remove the screw that secures the cylinder retainer and cylinder cover and remove both parts.
Note: If the unit has a bolt installed to the left of the LED. Remove this bolt to remove the push bar. (See Figure 1).

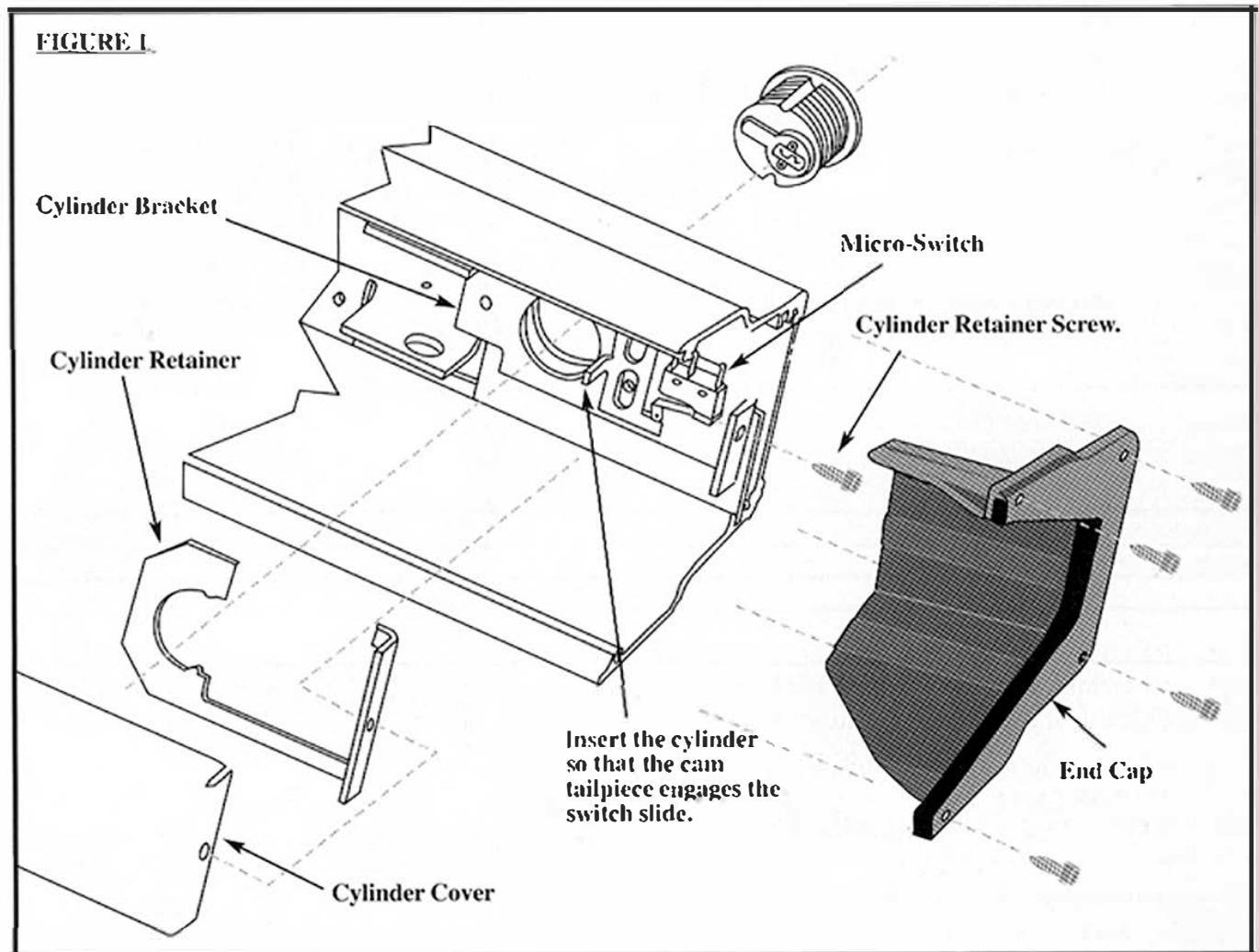

3. Unscrew the mortise cylinder and slide off the aluminum push bar toward the opposite end of the cylinder.
4. Loosen and remove the 1/4 inch hardware where the alarm sub-assembly attaches to the link arms in two (2) places (See Figure 2).
NOTE: Be careful not to lose the bronze bushings and steel sleeves as they will be reused.

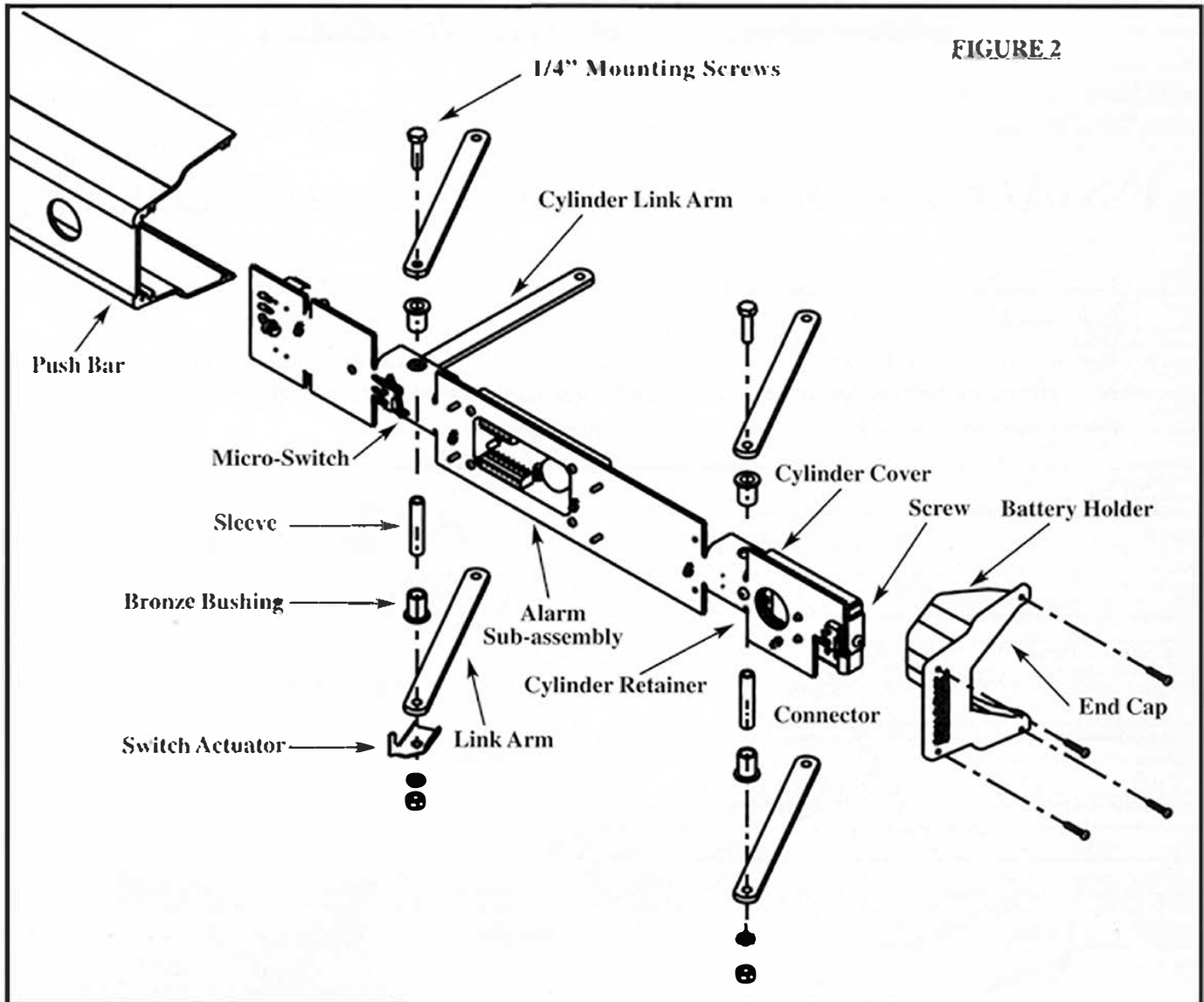

5. Remove the alarm sub-assembly and replace with the new assembly in the same orientation, reassembling the sleeves and the bushings in the proper location. Be sure to reattach the center link arm at the original location.
6. Install the new switch actuator over the link arm per Figure 2.
IMPORTANT: Make sure the actuator arm properly contacts the microswitch arm.
NOTE: Figure 1 & 2 is oriented with the key cylinder toward the right side of the unit, hinge side being on your right. If the key cylinder is to be installed on the left side, the alarm will be reversed in the upside down position.

7. Reinstall the 1/4 inch mounting hardware and tighten, making sure the lock washers are fully compressed.
8. Install two 9-volt alkaline batteries in the two locations on the backside of the push pad (opposite end from the key cylinder.)
9. Remove the end cap from the other end of the push bar. Install a new end cap to the end of the push bar using the screws provided.

- i0. Slide out the existing emergency label from the push bar and replace with the new one provided. Slide the aluminum push bar back over the alarm.

CAUTION: Take care when sliding the push bar past the switch, wires and actuator arm.

- ii. Reassemble the mortise cylinder and cylinder retainer that were previously removed. (See Figure 1).
- i2. Reassemble the cylinder cover over the cylinder retainer and secure them to the cylinder switch bracket using the original screw.
- i3. Replace the end cap on the key cylinder end of the push bar, using the new end cap and screws provided.
- i4. **IMPORTANT:** Turn the key towards the "ON" position, making sure you hear several beeps. The red LED light (located at the X in EXIT) will flash once every 10 seconds. If dip-switch #3 is flipped to the "ON" position, the LED will flash fast continuously for thirty-five seconds. (See Table 1 for settings). Then flash red once every 10 seconds. Open the door to ensure the alarm sounds.

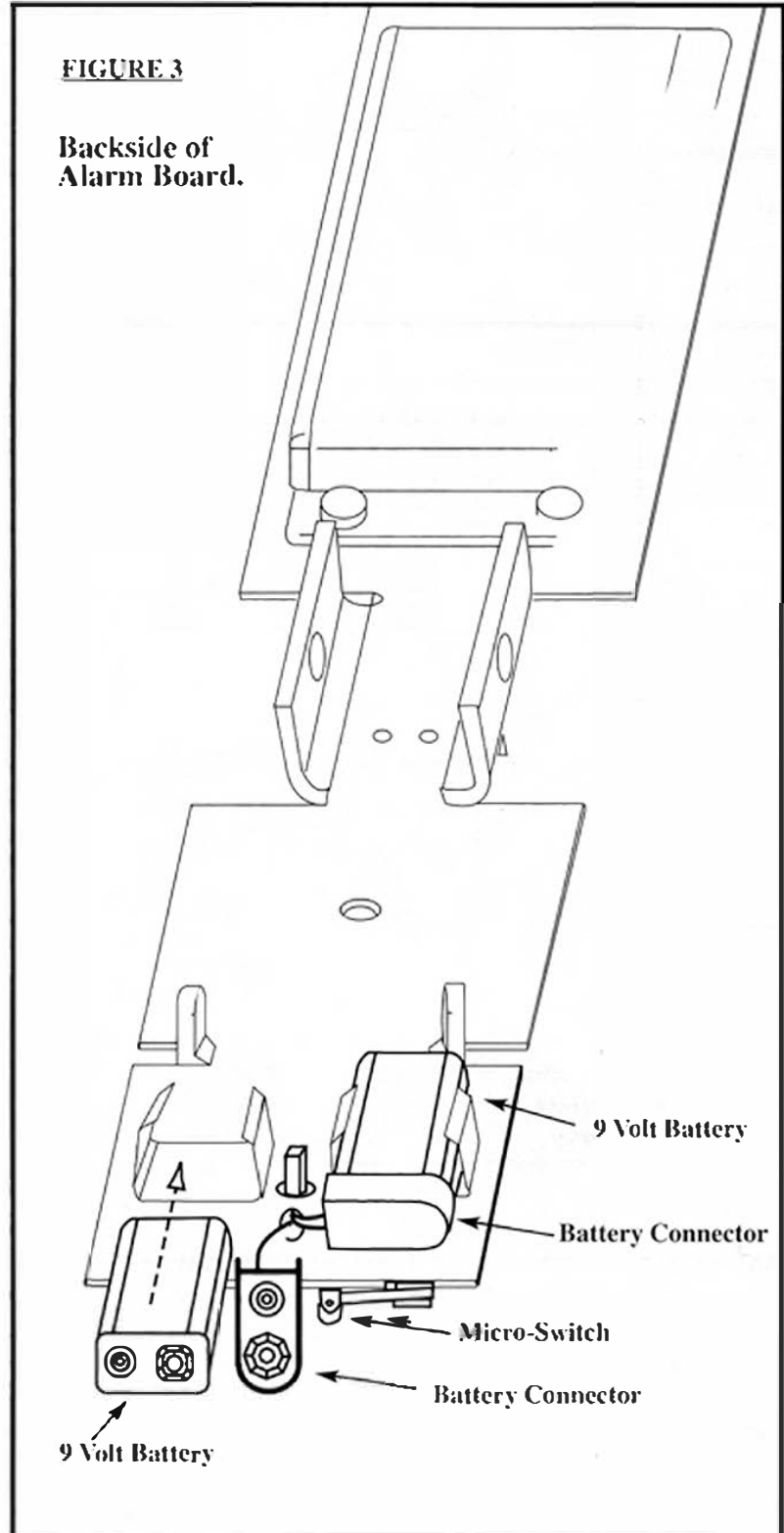

Table 1 Dip Switch Settings

MINUTES	DIPSWITCH SETTINGS
No Indication	1 & 2 OFF
15	2 OFF 1 ON
30	2 ON 1 OFF
60	1 & 2 ON

FUNCTIONS	DIPSWITCH SETTINGS
Factory Settings	3 OFF
35-Second Delay Enabled	3 ON
3-Second Nuisance Enabled	4 ON

NOTE FOR WARRANTY PURPOSES ONLY:

THE REPLACED ALARM SUB-ASSEMBLY AND END CAPS MUST BE REPACKAGED IN THE ORIGINAL SHIPPING CARTON AND RETURNED TO THE MANUFACTURER.

*If any parts are missing or damaged
or if you have any questions concerning the installation.*

*Please call **dormakaba USA Inc.** at **1-800-392-5209***

Corporate Headquarters

dormakaba USA Inc.
6161 East 75th Street
Indianapolis, IN 46250