

Double Door Adapter Kit A106-001 and A106-002 (Low Profile) Assembly

For online instructions, assistance or warranty information:
Call 1-800-392-5209 or visit <https://dhwsupport.dormakaba.com/hc/en-us>

ARM-A-DOR™

The Double Door Adapter Kit A106-001 is used with ARM-A-DOR models A101-001, A101-002, A102-001, and A102-002. The kit is intended for double door applications without a center mullion and can be used for any door jamb depth ranging from 4 3/4" to 6 3/4". For door jambs greater than 6 3/4", use the Double Door Adapter Kit A106-002 (Low Profile). All required tools are used in the installation of the ARM-A-DOR panic device.

Depending on the application, automatic flushbolts or deadbolts (not included) must be installed at the top and bottom of the inactive door, securing it in its frame. Two deadbolts are required and may be ordered from dormakaba USA Inc. Customer Service at 1-800-392-5209. Request either part number 1881-003 (Padlock Locking Deadbolt with Strike) or 1883-003 (Keylocking Deadbolt with Strike).

Assembly Instructions

These instructions must be followed after the

ARM-A-DOR device has been installed on the active door. The double door strike bracket must be installed on the inactive door as shown in Figure 1.

1. Attach drill template (Item 18) to inactive door and mark holes with a centerpunch.
2. Drill pilot holes through door with 1/4" drill bit.
3. Enlarge the pilot holes by drilling a 3/8" hole through the inside skin of the door only.
4. From outside the door, use a 5/8" hole saw to drill through the outside skin and insulation stopping before you reach the inside skin of the door.

Reminder: Adapter Kit A106-001 is used for door jamb depths from 4 3/4" to 6 3/4".

- For 4 3/4" jamb, use the shorter door brackets (item 4), door spacers (Item 17) and 3.50 lg carriage bolts (Item 7).
- For 6 3/4" jamb, use the longer door brackets (Item 4), door spacers (Item 17) and 3.50 lg carriage bolts (Item 7).
- For jamb depths greater than 6 3/4", use Adapter Kit A106-002.

5. Attach the two (2) door brackets (Item 3 or 4) to the double door strike bracket (Item 1 or 2) using a 3/8" hex hd bolt (Item 10), a support sleeve (Item 9), two (2) flat washers (Item 11), a lock washer (Item 12), and a hex nut (Item 13). See Figure 2.

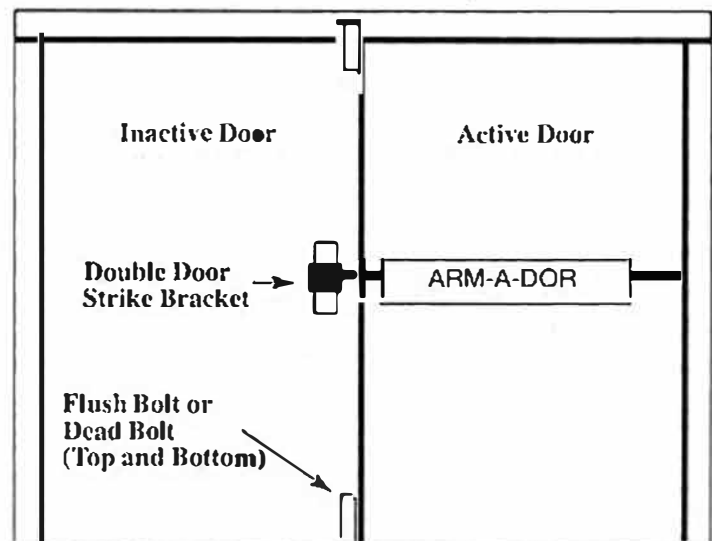

FIGURE 1

6. Fasten the double door strike bracket with door brackets attached to the door using two (2) sets of bolt washers (Item 5), carriage bolts (Item 6 or 7), support tubes (Item 8), flat washers (Item 11), lockwashers (Item 12), and hex nuts (Item 13). Leave hardware loose for adjustment.

7. For Low Profile applications, install mortise keeper (Item 19) and release angle (Item 20) using hardware kit (Item 21) on hinged side of door per Installation and Operations Guide and Figure 3.

8. Operate the door to make sure the bolt assembly engages the double door strike bracket and the roller bearings contact the strike surface inside the bracket.

Assembly Instructions

9. Tighten all hardware after adjusting the bracket.

10. Drill a 1/8" hole through the corner of the door bracket into the strike bracket as shown in Figure 2 and install the thread forming screw (Item 15) into hole.

11. Press the black end cap (Item 16) into the end of the bracket and two gray vinyl caps (Item) 14 over the end of the bolts on the door brackets.

Corporate Headquarters
 dormakaba USA Inc.
 6161 East 75th Street
 Indianapolis, IN 46250

ITEM	DESCRIPTION	-001	-002
1	Double door strike bracket	1	-
2	Double door strike bracket (Low Profile)	-	1
3	Door bracket	2	-
4	Door bracket (Low Profile)	2	-
5	Bolt washer	2	2
6	3/8" Carriage Bolt- 2.50" lg	2	2
7	3/8" Carriage Bolt- 3.50" lg	2	2
8	Support tube	2	2
9	Support sleeve	1	1
10	3/8" hex hd bolt	1	1
11	3/8" flat washer	4	4
12	3/8" star lock washer	3	3
13	3/8" hexnut	3	3
14	Vinyl cap (gray)	2	2
15	#6 thread form screw	1	1
16	End cap (black)	1	1
17	Door spacer	2	-
18	Drill template	1	1
19	Mortise keeper-	-	1
20	Release angle	-	1
21	Hardware kit	-	1

FIGURE 2:
 Double Door Adapter Kit

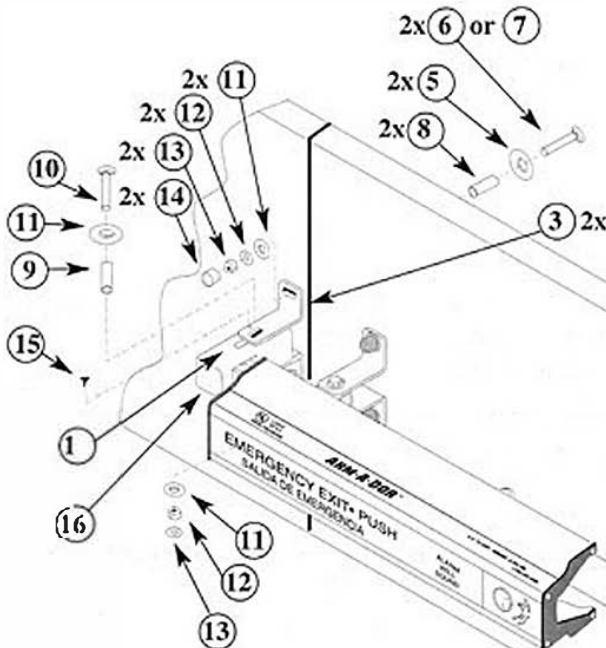
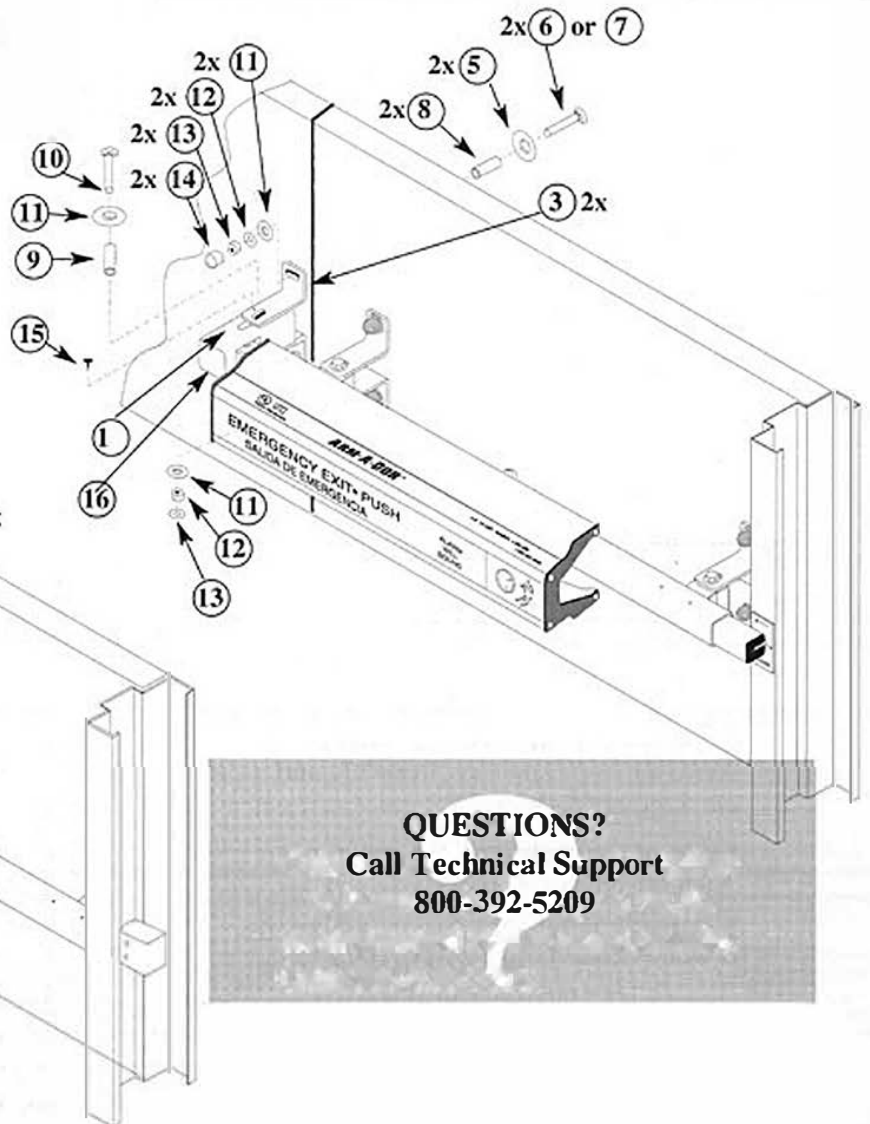

FIGURE 3:
 Double Door Adapter Kit
 (Low Profile)

QUESTIONS?
 Call Technical Support
 800-392-5209