

NOTES:

1. DO NOT SCALE DRAWING.
2. DIMENSIONS ARE IN INCHES/(MM).
3. RIGHT HAND DOOR SHOWN.
4. CAUTION: SEX NUTS ARE REQUIRED FOR ATTACHMENT OF COMPONENTS TO UNREINFORCED DOORS AND TO WOOD OR PLASTIC FACED COMPOSITE TYPE FIRE DOORS, UNLESS AN ALTERNATIVE METHOD IS IDENTIFIED IN THE INDIVIDUAL DOOR MANUFACTURER'S LISTINGS.
5. OPTIONAL DPK FASTENERS (DPK86) FOR STEEL DOOR & FRAME ONLY.

DEGREE OF DEAD STOP	DIM. "B" ARM SHOE	DIM. "C" PLATE
85°	13-7/8 (352)	8-1/2 (216)
90°	13-1/2 (343)	7-13/16 (198)
95°	13-1/4 (337)	7 (178)
100°	12-5/8 (321)	6-15/16 (176)
105°	12-1/4 (311)	6-1/2 (165)
110°	11-7/8 (302)	6-1/16 (154)

FOR 1/4-20 MACHINE SCREWS USE 7/32" DRILL & TAP
 FOR No.14 WOOD SCREWS USE 5/32" DRILL
 DPK FASTENERS DRILL 1/8" PILOT HOLE
 TWO (2) HOLES IN FRAME FOR ARM SHOE

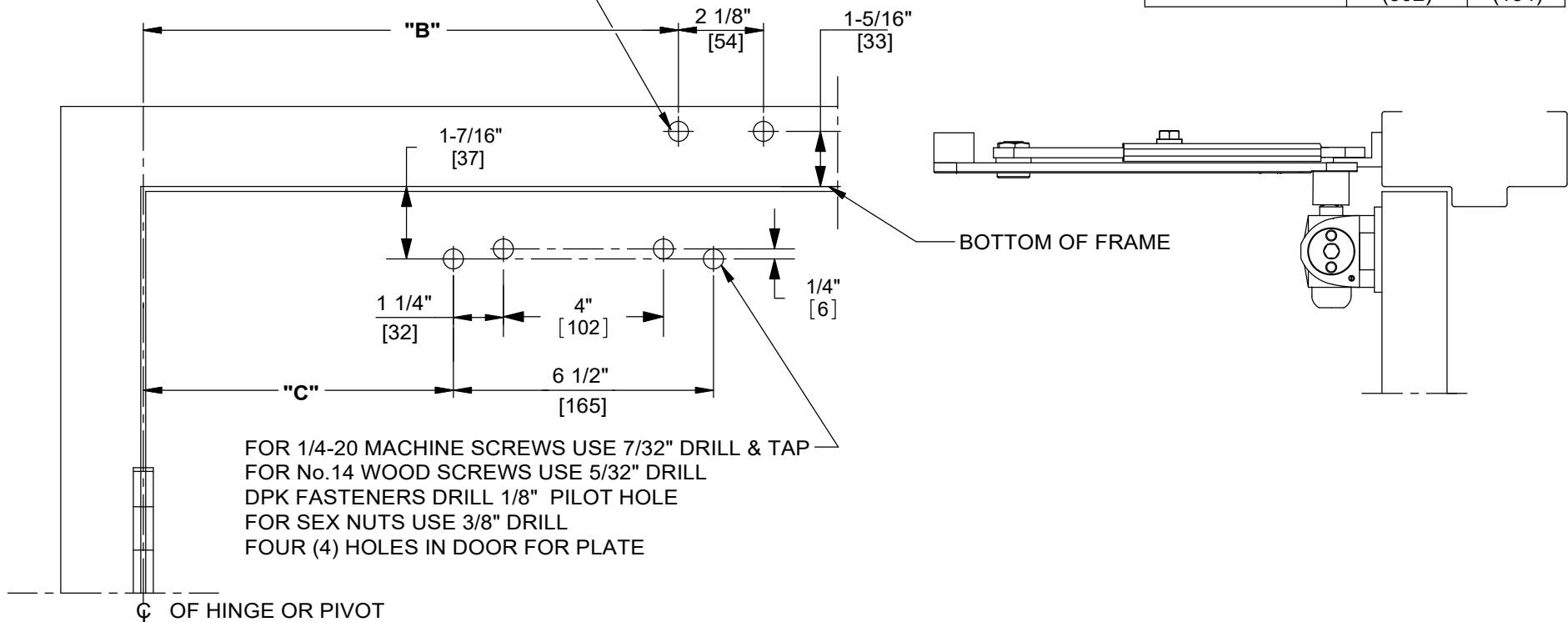

FOR 1/4-20 MACHINE SCREWS USE 7/32" DRILL & TAP
 FOR No.14 WOOD SCREWS USE 5/32" DRILL
 DPK FASTENERS DRILL 1/8" PILOT HOLE
 FOR SEX NUTS USE 3/8" DRILL
 FOUR (4) HOLES IN DOOR FOR PLATE

DOOR CLOSER MODELS: 7400 IS, ISH
 REGULAR INSTALLATION (PULL SIDE MOUNT)
 DEAD STOP ARM
 WITH PLATES BP74, BP86, BP86FC