

**Door Closer Models: HD7016 DST
Door Saver (Parallel Arm Mount) with Drop Plate DP70
for Use with Standard Spacer Block
for Use with Optional NFHD Bracket
Template/Drilling Instructions**

Always consult BEST's website for the latest template at
<https://dhwsupport.dormakaba.com/hc/en-us> or call 1-800-392-5209.

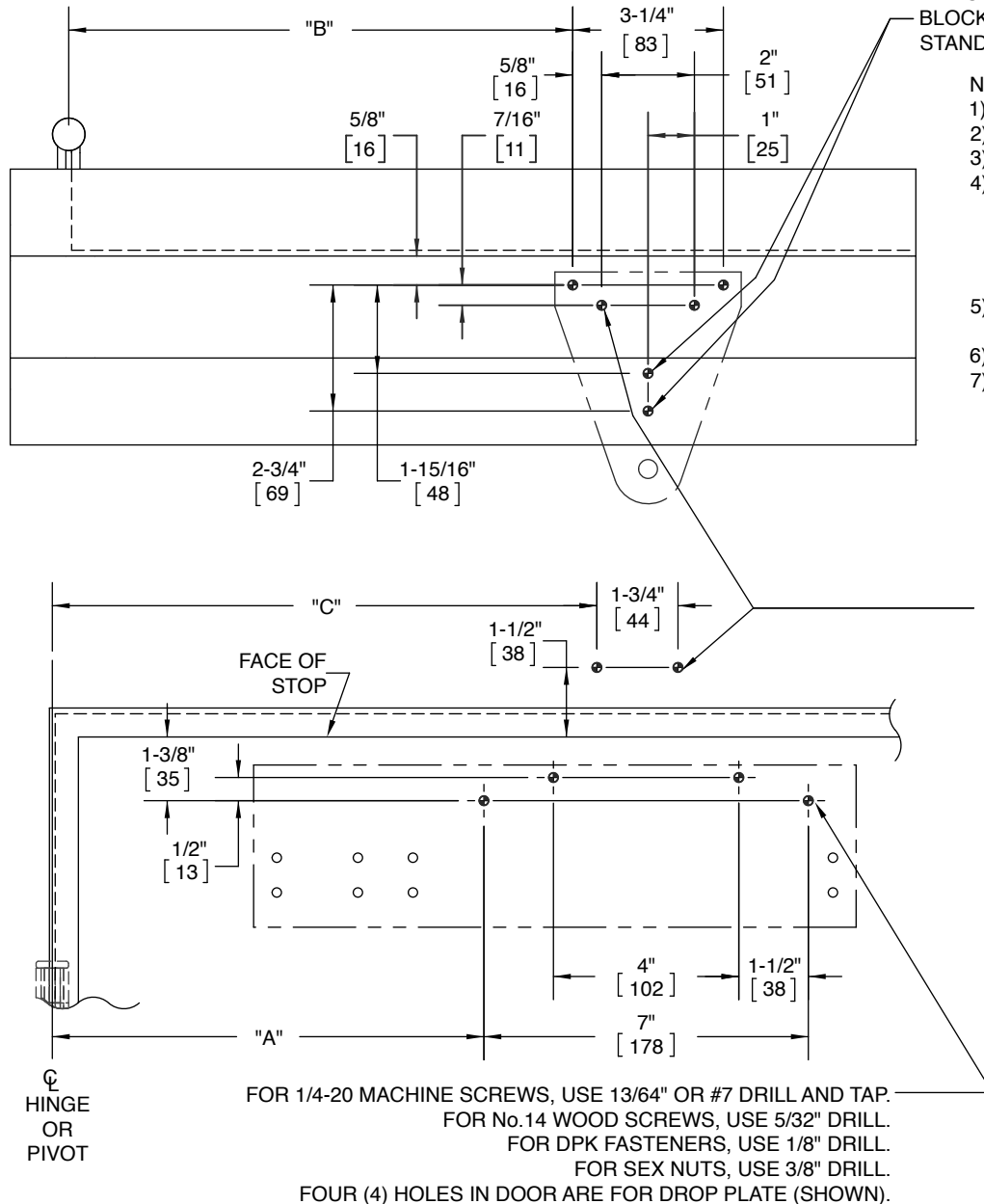

***IMPORTANT: CHOOSE APPROPRIATE FIFTH HOLE LOCATION FOR SPACER BLOCK, IN ACCORDANCE WITH FRAME WIDTH. ONE (1) HOLE IN FRAME FOR STANDARD BLOCK. PREPARE HOLE THE SAME AS SOFFIT PLATE HOLES**

NOTES:

- 1) DRAWING IS NOT TO SCALE.
- 2) DIMENSIONS ARE IN INCHES/[MM].
- 3) LEFT HAND DOOR IS SHOWN.
- 4) CAUTION: SEX NUTS ARE REQUIRED FOR ATTACHMENT OF COMPONENTS TO UNREINFORCED DOORS AND TO WOOD OR PLASTIC FACED COMPOSITE TYPE FIRE DOORS, UNLESS AN ALTERNATIVE METHOD IS IDENTIFIED IN THE INDIVIDUAL DOOR MANUFACTURER'S LISTINGS.
- 5) FOR FRAME WIDTHS 4-1/2" AND LESS, USE OPTIONAL NFHD BRACKET W/O STANDARD SPACER BLOCK.
- 6) MINIMUM DOOR WIDTH IS 26".
- 7) DPK FASTENERS FOR STEEL DOOR AND FRAME ONLY.

FOR 1/4-20 MACHINE SCREWS,
USE 13/64" OR #7 DRILL AND TAP.
FOR No.14 WOOD SCREWS,
USE 5/32" DRILL.
FOR DPK FASTENERS,
USE 1/8" DRILL.
FIVE (5) HOLES IN FRAME ARE FOR
SOFFIT PLATE.
OPTIONAL TWO (2) HOLES IN FRAME
ARE FOR NFHD BRACKET.

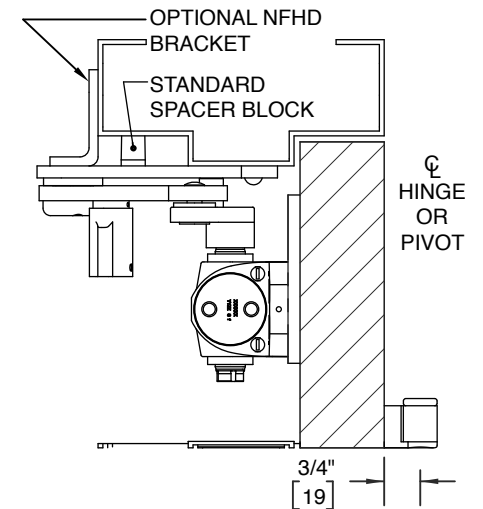

ANGLE OF HOLD OPEN	ANGLE OF CUSHION	DIM. "A" (DROP PLATE)	DIM. "B" (SOFFIT PLATE)	DIM. "C" (NFHD BRACKET)
85°	86° - 88°	9-5/16" [237]	10-7/8" [276]	11-3/4" [298]
90°	91° - 93°	8-9/16" [217]	10-1/8" [257]	11" [279]
100°	101° - 103°	7-3/16" [183]	8-3/4" [222]	9-5/8" [244]
110°	111° - 113°	6-3/16" [157]	7-3/4" [197]	8-5/8" [219]