

# HD7016 AR/ARJ/ARP

Round arm for regular, top jamb, parallel mount

## Installation Instructions

### OVERVIEW

- 1** Door closer

---

- 2** Main arm

---

- 3** Connecting arm (round)

---

- 4** Shoe and rod

---

- 5** Dust cap

---

- 6** Flat head combo screws

---

- 7** Pan head combo screws

---

- 8** Pinion screw

---

- 9** PA bracket

---

- 10** PA shoe screws

### AR regular mount–Round arm (AR)

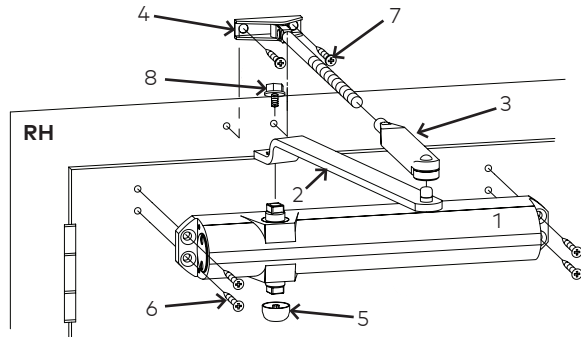

### AR top jamb mount–Round arm (AR)

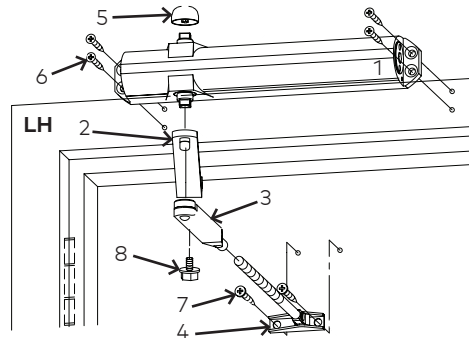

### AR parallel mount–Round arm (AR)

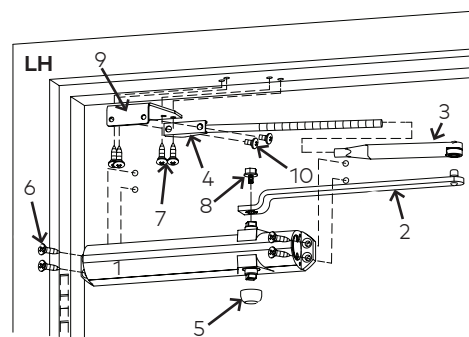



# Table of contents

<b>1</b>	<b>Technical specifications</b>	<b>3</b>
1.1	Overview	3
1.2	Tools recommended	3
1.3	Handing the door	3
<b>2</b>	<b>Instructions - AR regular mount</b>	<b>4</b>
2.1	Closer system: Round arm (AR)	4
2.2	Installing backplate and surface closer	4
2.3	Installing arms (AR)	4
<b>3</b>	<b>Instructions - AR top jamb mount</b>	<b>5</b>
3.1	Closer system: Round arm (AR)	5
3.2	Installing plate and surface closer	5
3.3	Installing arms (AR)	5
<b>4</b>	<b>Instructions - AR parallel mount</b>	<b>6</b>
4.1	Closer system: Round arm (AR)	6
4.2	Installing drop plate and closer	6
4.3	Installing parallel mount bracket and arms (AR)	6
<b>5</b>	<b>Adjustments</b>	<b>7</b>
5.1	Adjust closing speeds: sweep, latch, backcheck, delayed action if applicable	7
5.2	Adjust spring force	8
<b>6</b>	<b>Install covers</b>	<b>8</b>

# 1 Technical specifications

## 1.1 Overview

 Caution: sex nuts are required for attachment of components to unreinforced doors and to wood or plastic faced composite type fire doors, unless an alternative method is identified in the individual door manufacturer's listings.

 Maximum door opening degree is 180°.

 Know the swing of the door which is being installed prior to installation.

 Verify closer spring size prior to installation.

 Make sure door efficiently operates prior to installing closer.

 Do not hammer arm onto spindle. Warranty will be void.

## 1.2 Tools recommended

Table 1

Drill bits:	#3 Phillips screwdriver
Metal: 7/32" drill bit; 1/4-20 tap	3/16" flat head screwdriver
Wood: 3/8" and 5/32" bit	5mm hex key
1/2" box wrench	

## 1.3 Handing the door

Fig.1

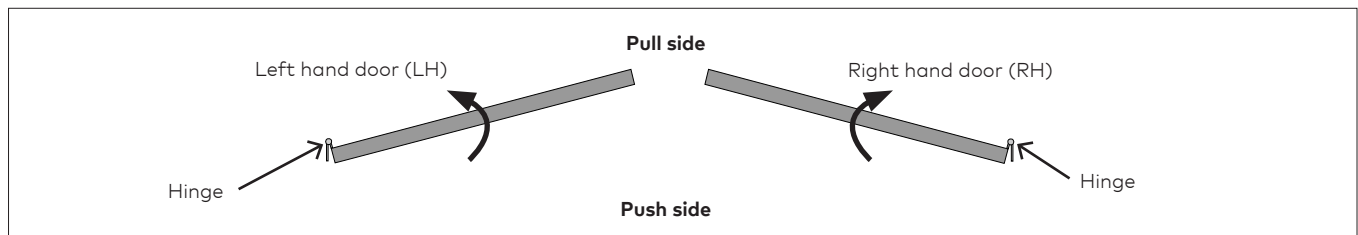

# 2 Instructions - AR regular mount

## 2.1 Closer system: Round arm (AR)

Fig.2

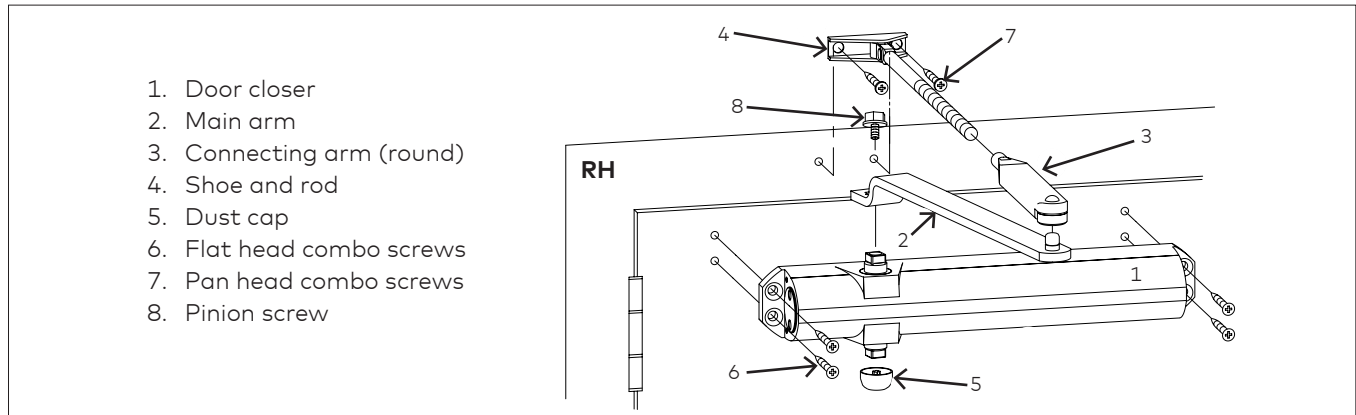

## 2.2 Installing backplate and surface closer

Fig.3

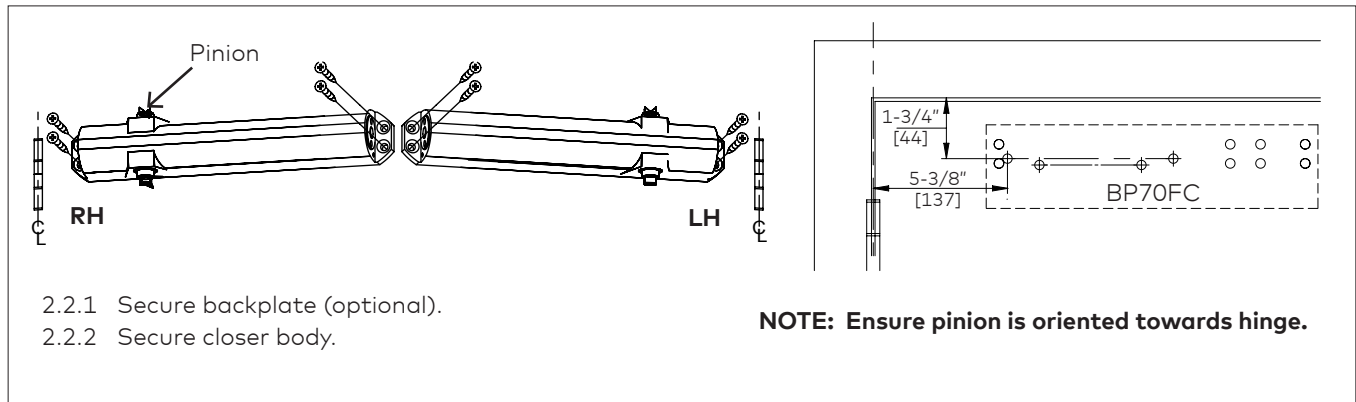

## 2.3 Installing arms (AR)

Fig.4

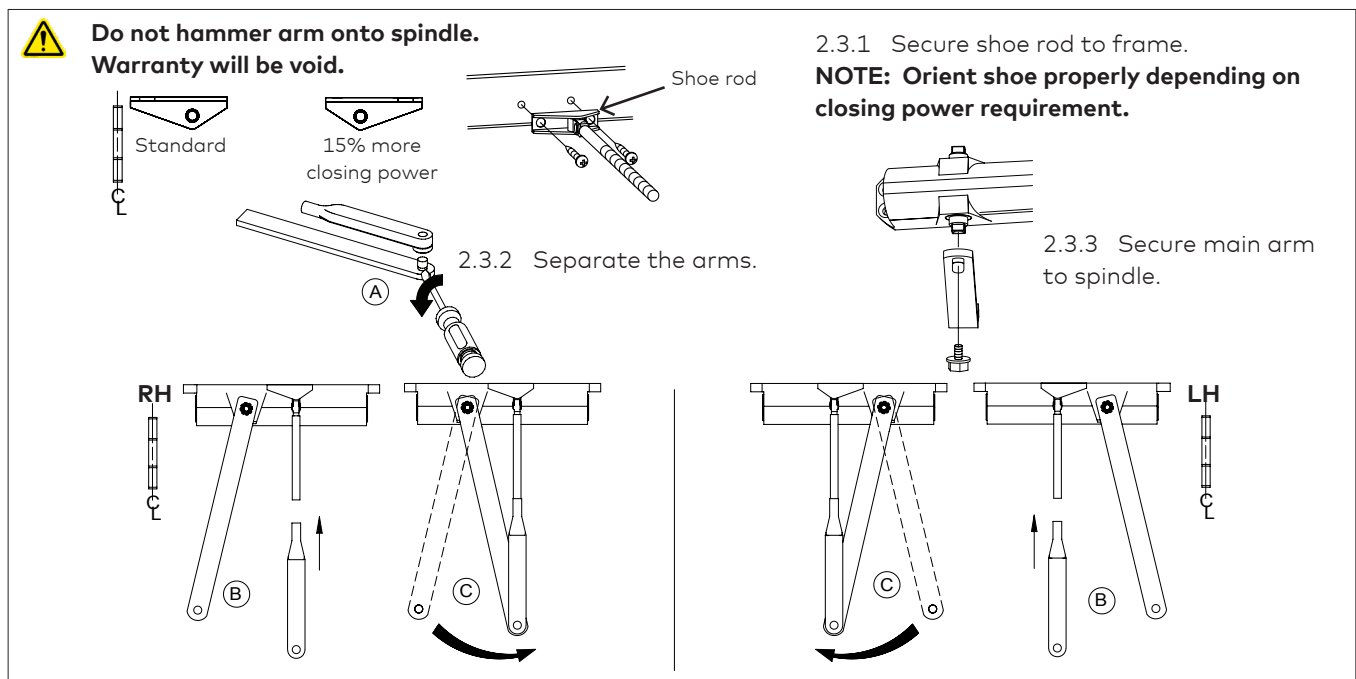

# 3 Instructions - AR top jamb mount

## 3.1 Closer system: Round arm (AR)

Fig.5

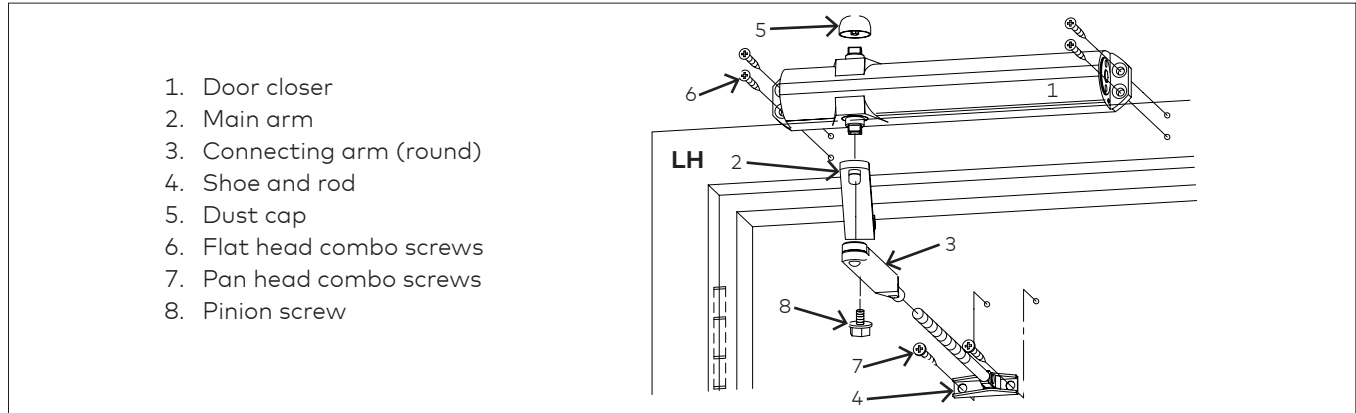

## 3.2 Installing plate and surface closer

Fig.6

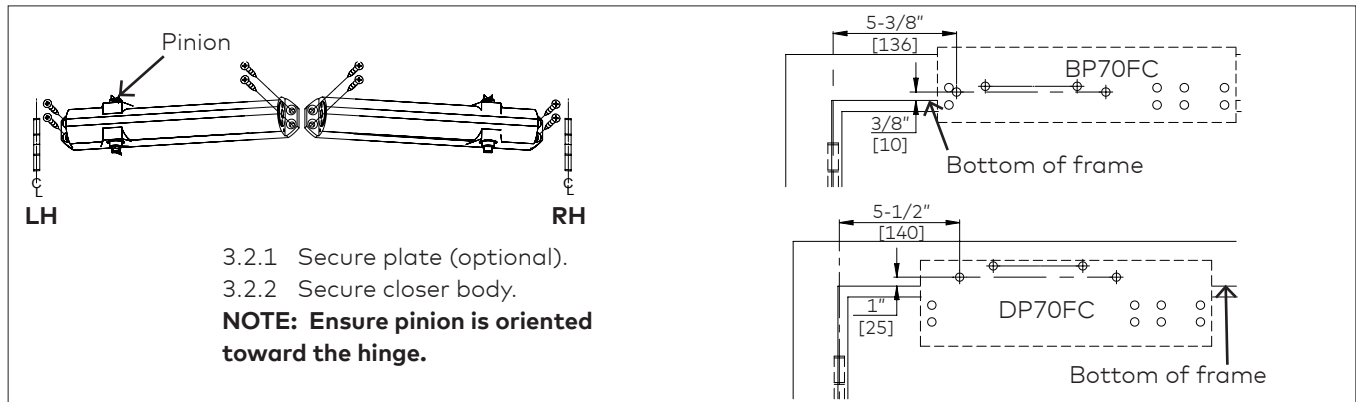

## 3.3 Installing arms (AR)

Fig.7

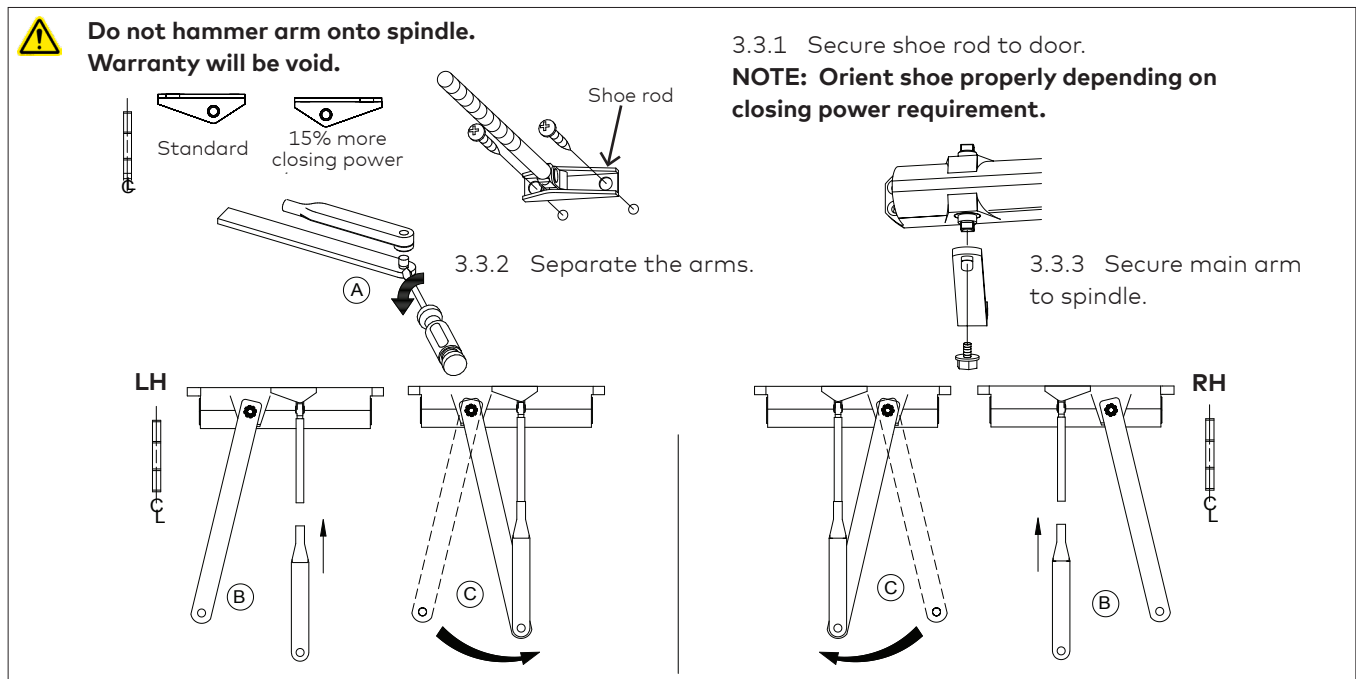

# 4 Instructions - AR parallel mount

## 4.1 Closer system: Round arm (AR)

Fig.8

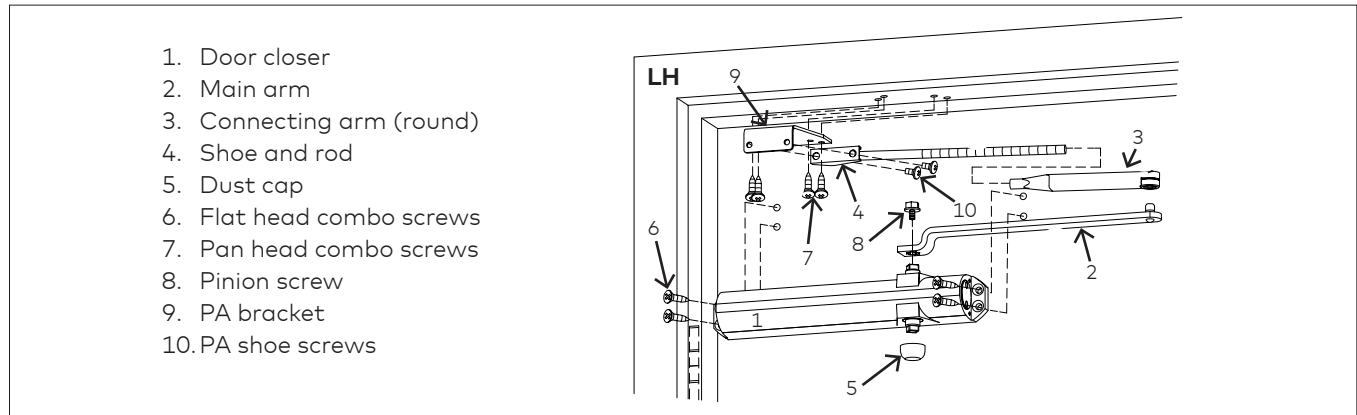

## 4.2 Installing drop plate and closer

Fig.9

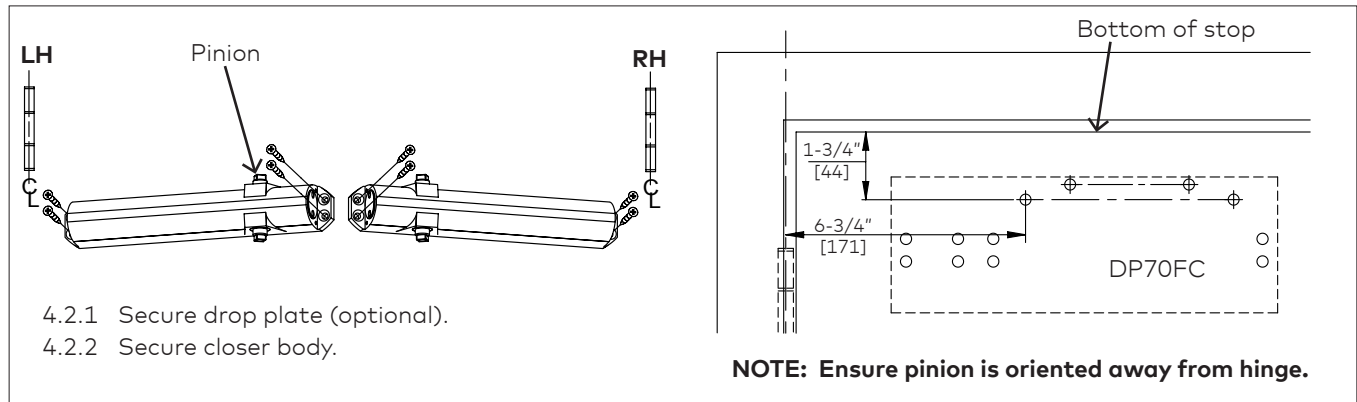

## 4.3 Installing parallel mount bracket and arms (AR)

Fig.10

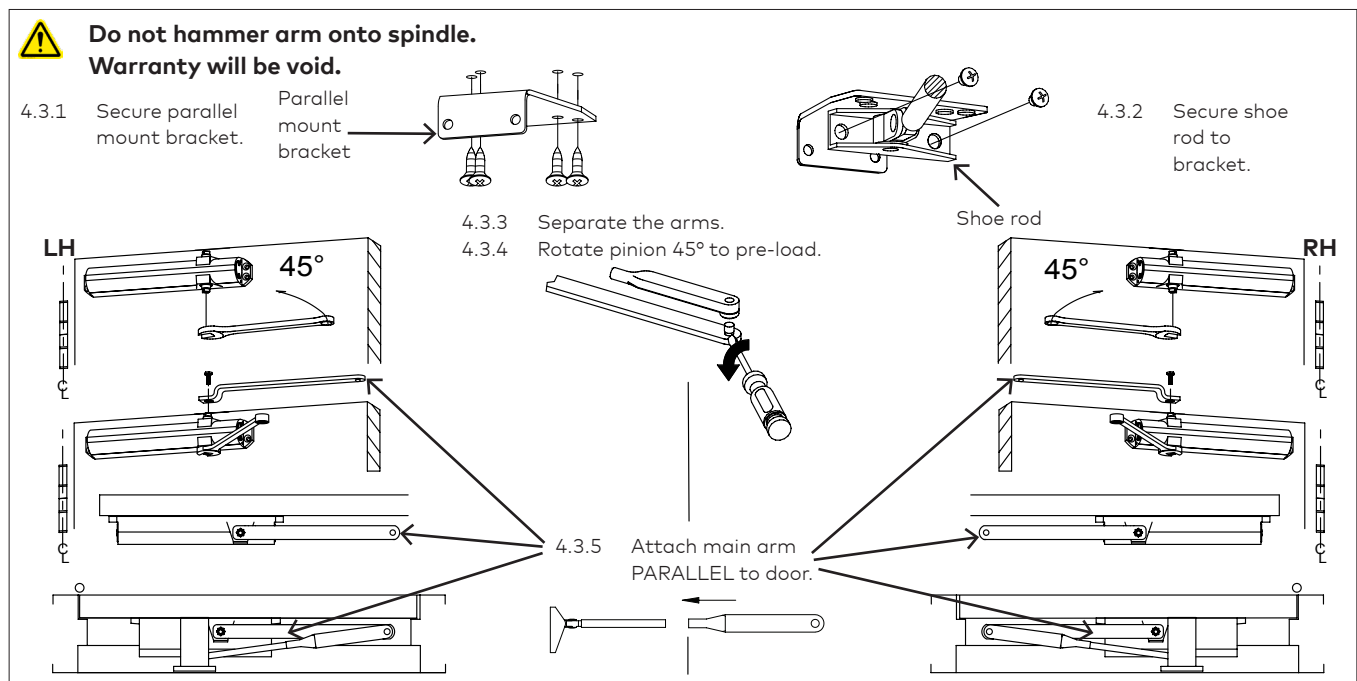

# 5 Adjustments

- ⚠ Confirm closer spring size prior to making any closing speed adjustments.
- ⚠ Do not back valve heads out beyond closer casting.
- ⚠ Backcheck positioning MUST be turned "ON" for parallel arm applications.
- ⚠ Backcheck position will advance approximately 15°.
- ⚠ Check delayed action (DA) function if supplied.
- ⚠ Maximum opening angle is 180°.
- ⚠ Door should close in 3 to 6 seconds from 90°.
- ⚠ Do not close valves completely.
- ⚠ Ball bearing hinges and pivots should always be used.
- ⚠ 7016 meets 5lb interior barrier-free requirements. If necessary, adjust closer spring and test pull forces until proper forces are obtained.

## 5.1 Adjust closing speeds: sweep, latch, backcheck, delayed action if applicable

Fig.11

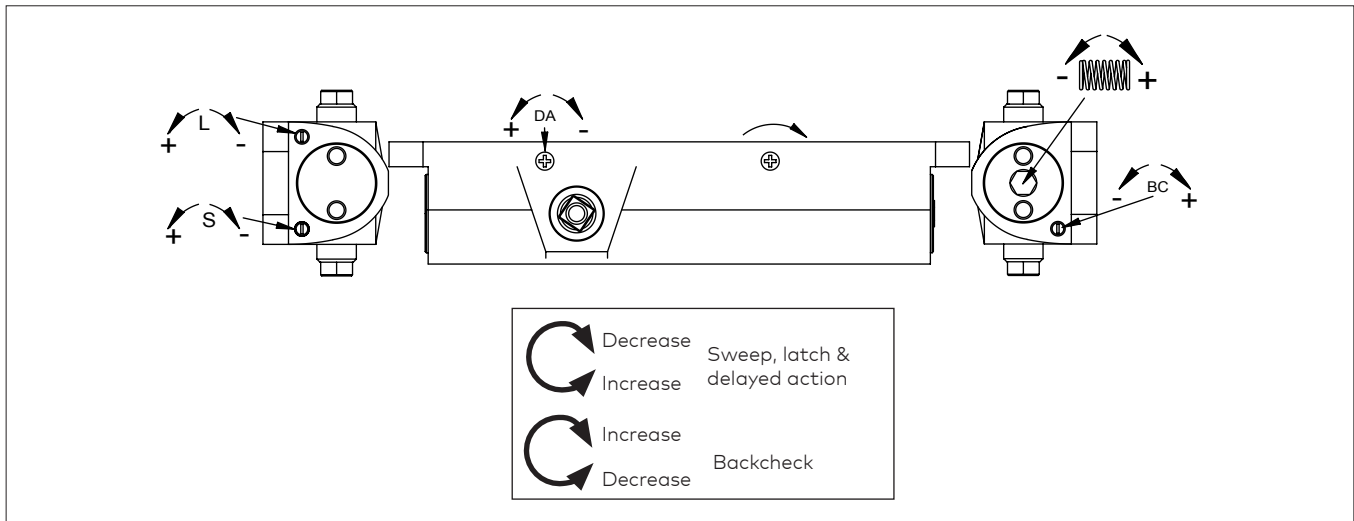

## 5.2 Adjust spring force

Fig.12

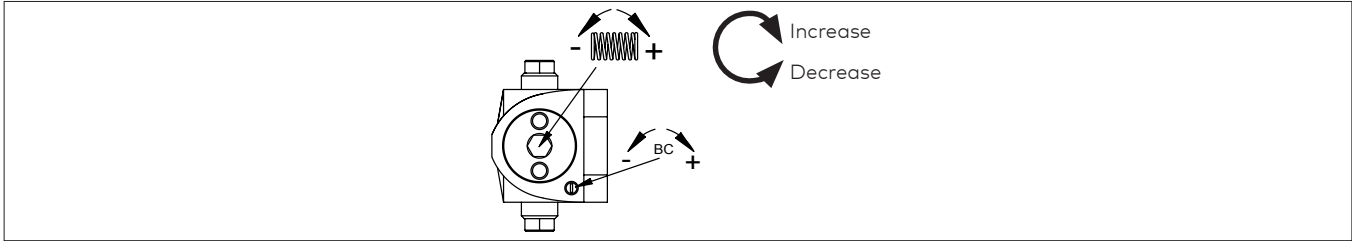

Regular and top jamb mount					
	Closer size	Max door weight (lbs)	Door width		Full turns
			Interior	Exterior	
HD7016	2	100	2'6"	----	-19
	3	125	3'	2'6"	-11
	4	150	3'6"	3'	0
	5	200	4'	3'6"	+5
	6	250	----	4'	+13
Parallel mount					
HD7016	3	100	2'6"	----	-11
	4	125	3'	2'6"	0
	5	150	3'6"	3'	+5
	6	200	4'	3'6"	+13

## 6 Install covers

Fig.13

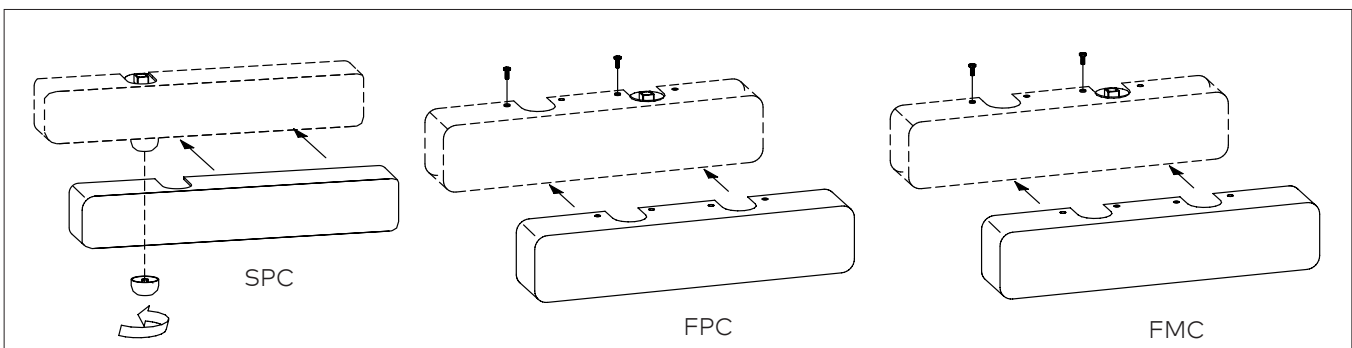

For Complete Online Instructions Visit:  
<https://dhwsupport.dormakaba.com/hc/en-us>

For Assistance or Warranty Information:  
 Call 1-800-392-5209 or visit  
<https://dhwsupport.dormakaba.com/hc/en-us>