

**Door Closer Models: HD7016 SPA, SPAT  
Super Parallel Arm (Push Side Mount)  
with Standard Spacer Block  
Optional NFHD Bracket and BSHD Blade Stop Spacer Block  
Template/Drilling Instructions**

Always consult BEST's website for the latest template at  
<https://dhwsupport.dormakaba.com/hc/en-us> or call 1-800-392-5209.

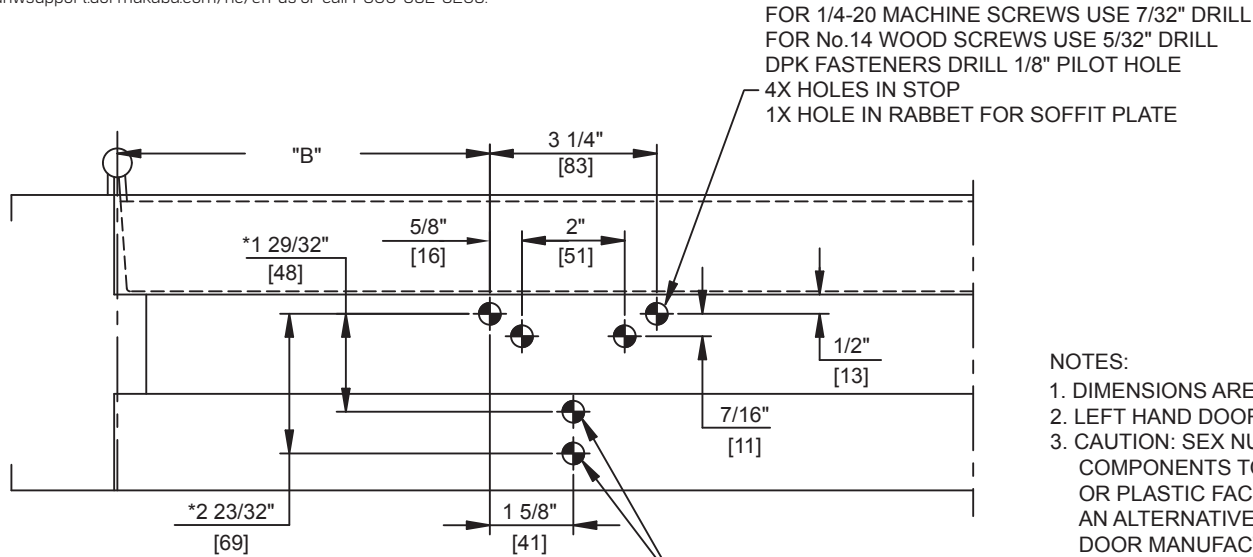

ANGLE OF OPENING HOLD OPEN	DIM. "A" CLOSER	DIM. "B" SOFFIT PLATE	DIM. "C" (NFHD) BRACKET OPTIONAL
TO 100° H.O. 90°	$\frac{4-7/8}{(124)}$	$\frac{10-1/8}{(257)}$	$\frac{11}{(279)}$
TO 180° H.O. 125°	$\frac{1-1/4}{(32)}$	$\frac{6-1/2}{(165)}$	$\frac{7-3/8}{(187)}$

\*IMPORTANT: CHOOSE APPROPRIATE HOLE LOCATION FOR SPACER BLOCK, IN ACCORDANCE WITH FRAME WIDTH.

**NOTES:**

1. DIMENSIONS ARE IN INCHES/(MM).
2. LEFT HAND DOOR SHOWN.
3. CAUTION: SEX NUTS ARE REQUIRED FOR ATTACHMENT OF COMPONENTS TO UNREINFORCED DOORS AND TO WOOD OR PLASTIC FACED COMPOSITE TYPE FIRE DOORS, UNLESS AN ALTERNATIVE METHOD IS IDENTIFIED IN THE INDIVIDUAL DOOR MANUFACTURER'S LISTINGS.
4. FOR FRAME WIDTHS 4-1/2" AND LESS USE OPTIONAL (NFHD) BRACKET.
5. MINIMUM DOOR WIDTH 26".
6. TEMPLATE BASED ON 4-1/2" x 4-1/2" BUTT HINGES.
7. HOLD OPEN AND DEAD STOP ARE SAME LOCATION.
8. DPK FASTENERS FOR STEEL DOOR & FRAME ONLY.

