

HD7016 A08/A08J/A08P

Round arm secure for regular, top jamb and parallel mounts with no hold open

Installation Instructions

OVERVIEW

- 1** Closer body

- 2** Main arm

- 3** Bar and shoe

- 4** Connecting arm

- 5** Dust cap

- 6** Flat head combo screws

- 7** Pan head combo screws

- 8** Pinion screw

- 9** Connecting arm screw

- 10** PA shoe screws

- 11** PA bracket

Regular mount

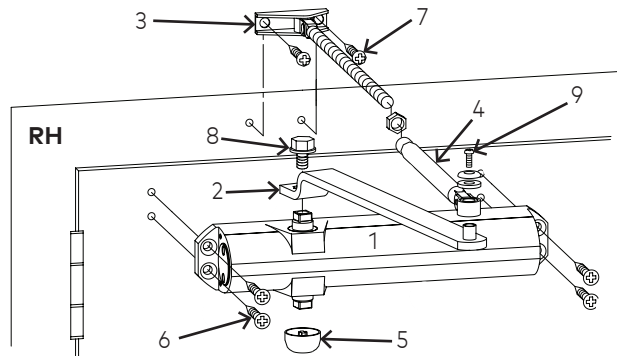

Top jamb mount

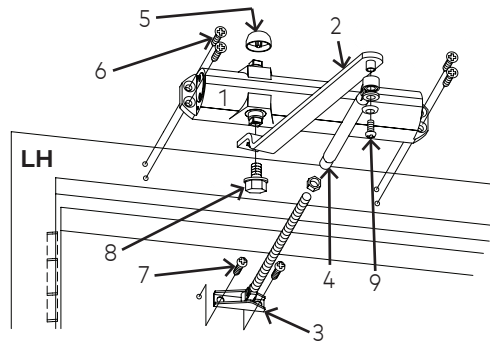

Parallel mount

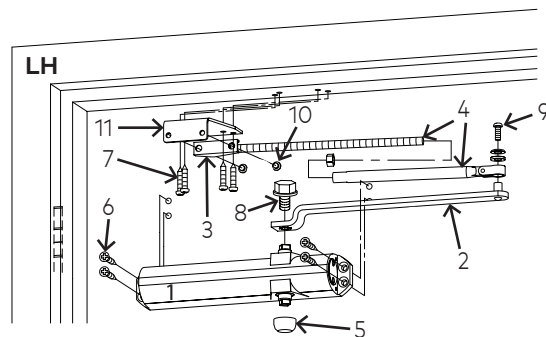



Table of contents

1	Technical specifications	3
1.1	Overview	3
1.2	Tools recommended	3
1.3	Handing the door	3
2	Installation - regular mount	4
2.1	Surface closer system	4
2.2	Installing the surface closer and backplate (optional)	4
2.3	Installing arm shoe and arm	4
3	Instructions - top jamb mount	5
3.1	Surface closer system	5
3.2	Installing the surface closer and (optional) plate	5
3.3	Installing arm shoe and arm	5
4	Instructions - parallel mount	6
4.1	Surface closer system	6
4.2	Installing the surface closer and drop plate (optional)	6
4.3	Installing parallel bracket, arm shoe and arm	6
5	Adjustments	7
5.1	Adjust closing speeds: sweep, latch, backcheck, delayed action if applicable	7
5.2	Adjust spring force	8
6	Install covers	8

1 Technical specifications

1.1 Overview

 Caution: sex nuts are required for attachment of components to unreinforced doors and to wood or plastic faced composite type fire doors, unless an alternative method is identified in the individual door manufacturer's listings.

 Maximum door opening degree is 180°.

 Maximum 4-1/2" reveal on top jamb mounts for 180° degree openings.

 Know the swing of the door which is being installed prior to installation.

 Verify closer spring size prior to installation.

 Make sure door efficiently operates prior to installing closer.

 Do not hammer arm onto spindle. Warranty will be void.

1.2 Tools recommended

Table 1

Drill bits:	#3 Phillips screwdriver
Metal: 7/32" drill bit; 1/4-20 tap	3/16" flat head screwdriver
Wood: 3/8" and 5/32" bit	5mm hex key
1/2" box wrench	7/16" box wrench

1.3 Handing the door

Fig.1

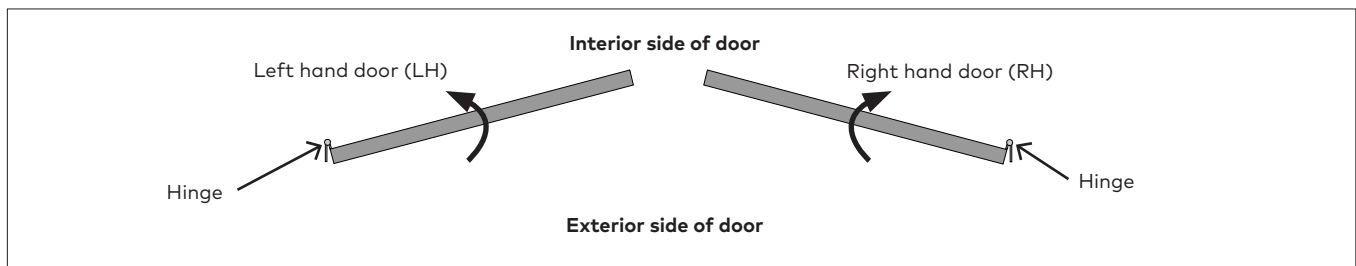

2 Installation - regular mount

2.1 Surface closer system

Fig.2

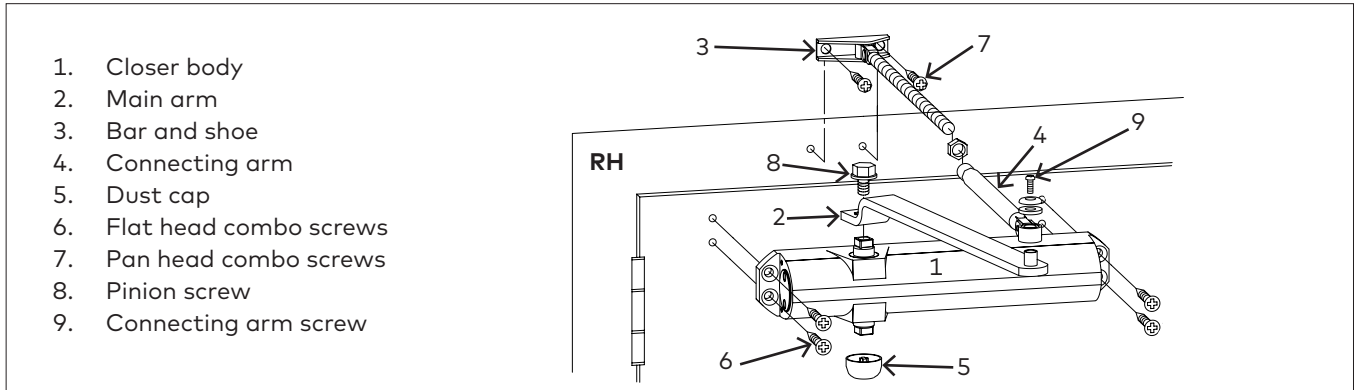

2.2 Installing the surface closer and backplate (optional)

Fig.3

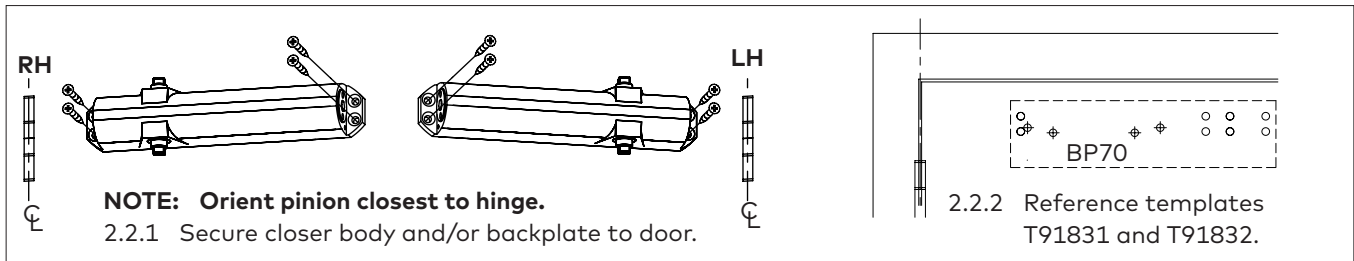

2.3 Installing arm shoe and arm

Fig.4

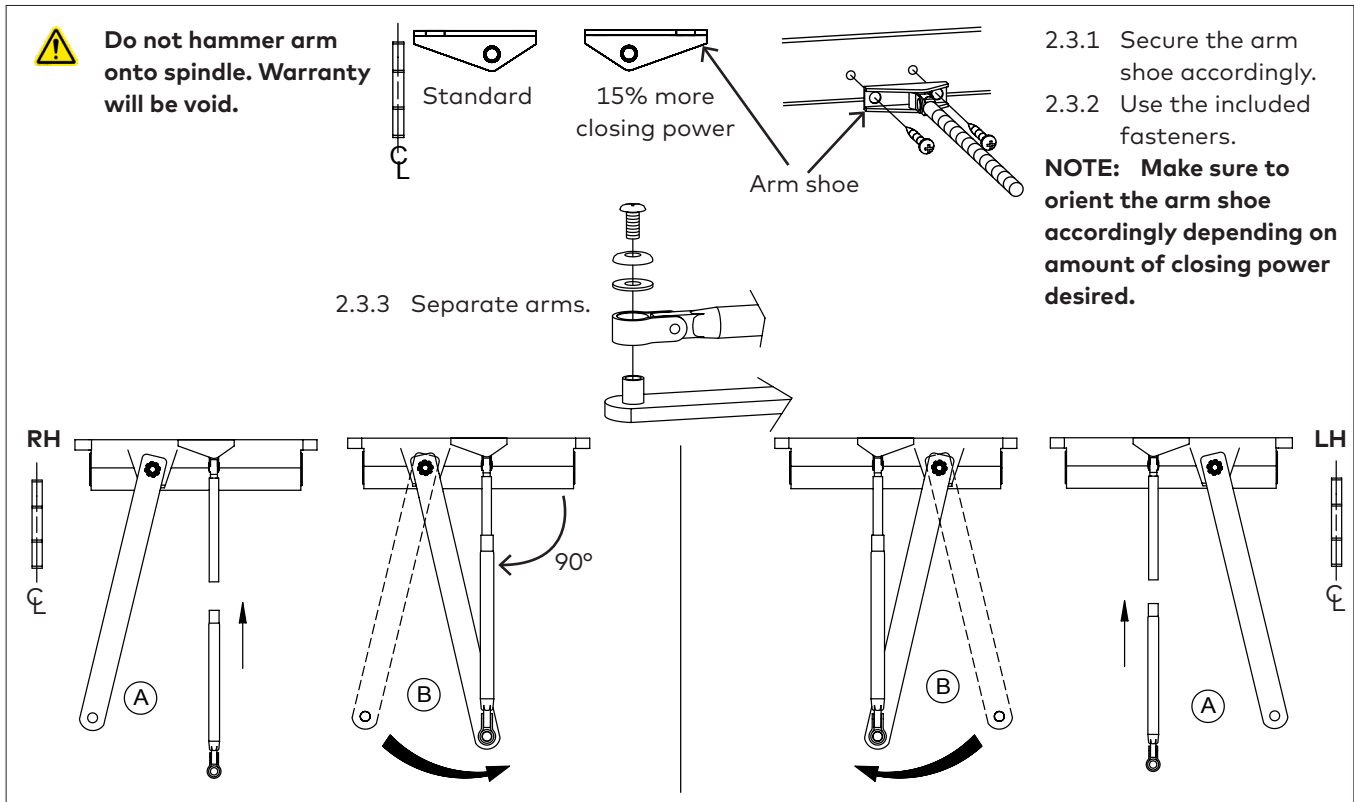

3 Instructions - top jamb mount

3.1 Surface closer system

Fig.5

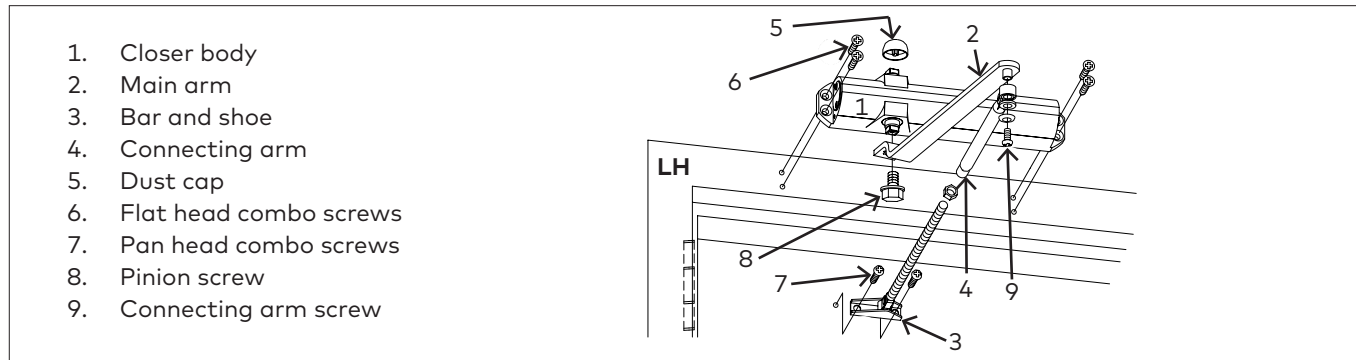

3.2 Installing the surface closer and (optional) plate

Fig.6

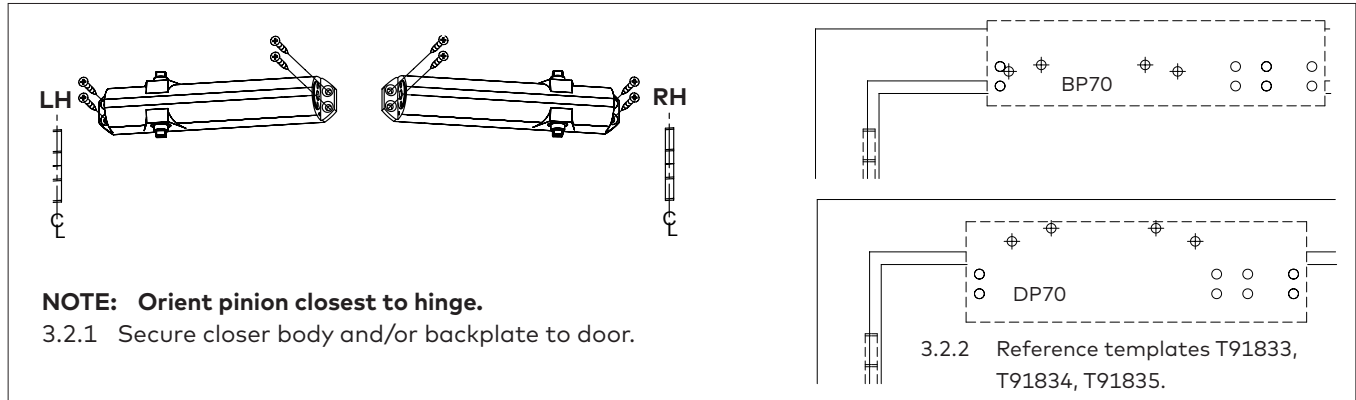

3.3 Installing arm shoe and arm

Fig.7

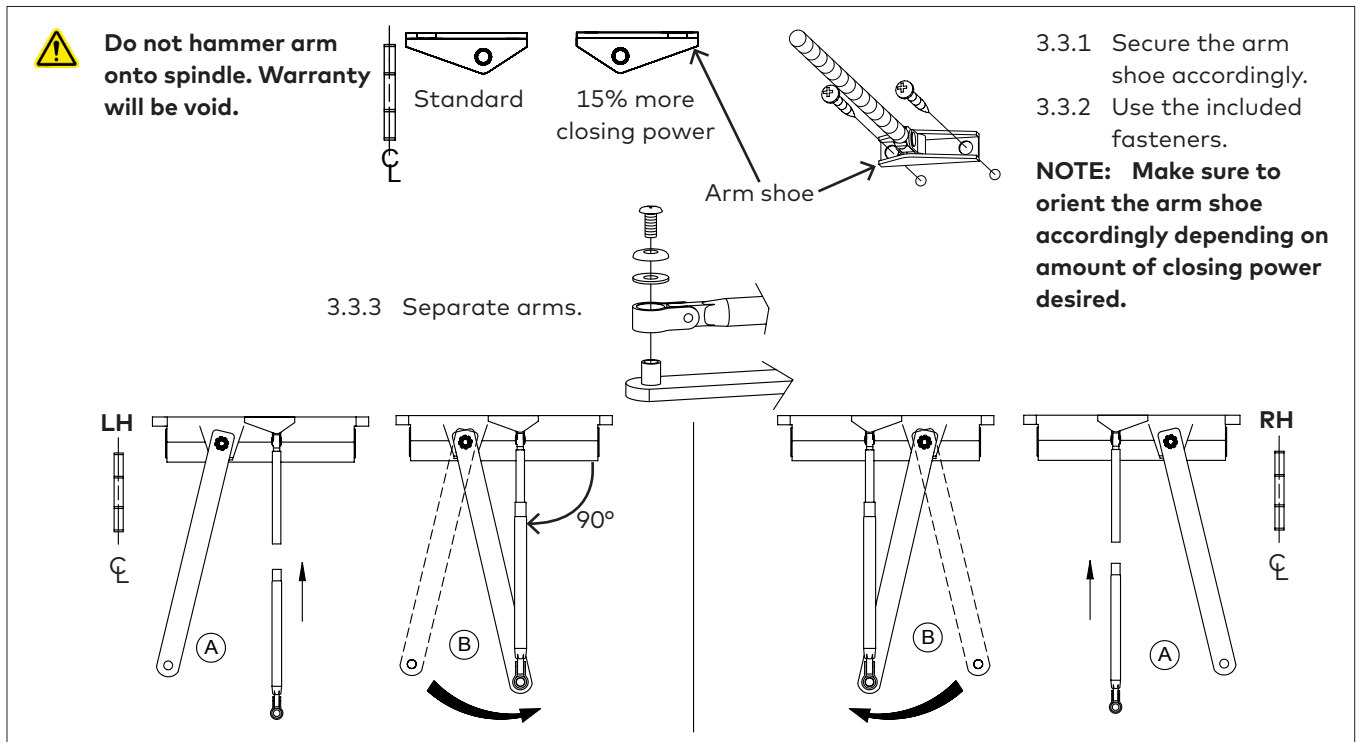

4 Instructions - parallel mount

4.1 Surface closer system

Fig.8

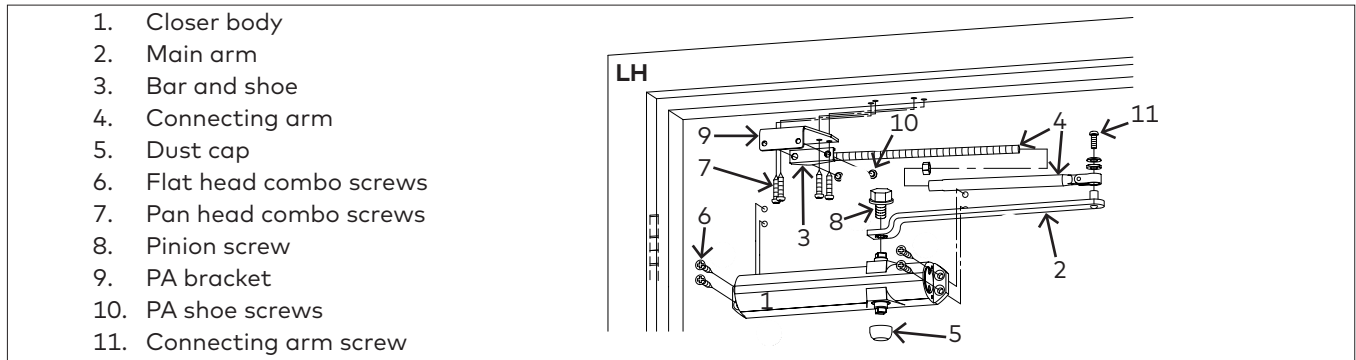

4.2 Installing the surface closer and drop plate (optional)

Fig.9

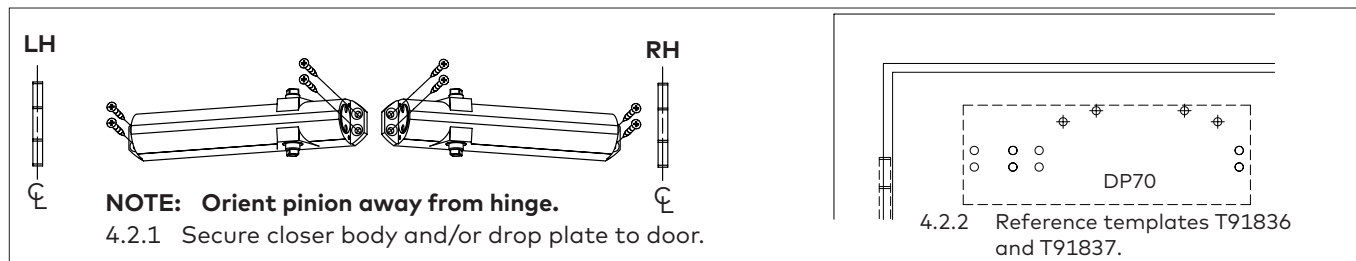

4.3 Installing parallel bracket, arm shoe and arm

Fig.10

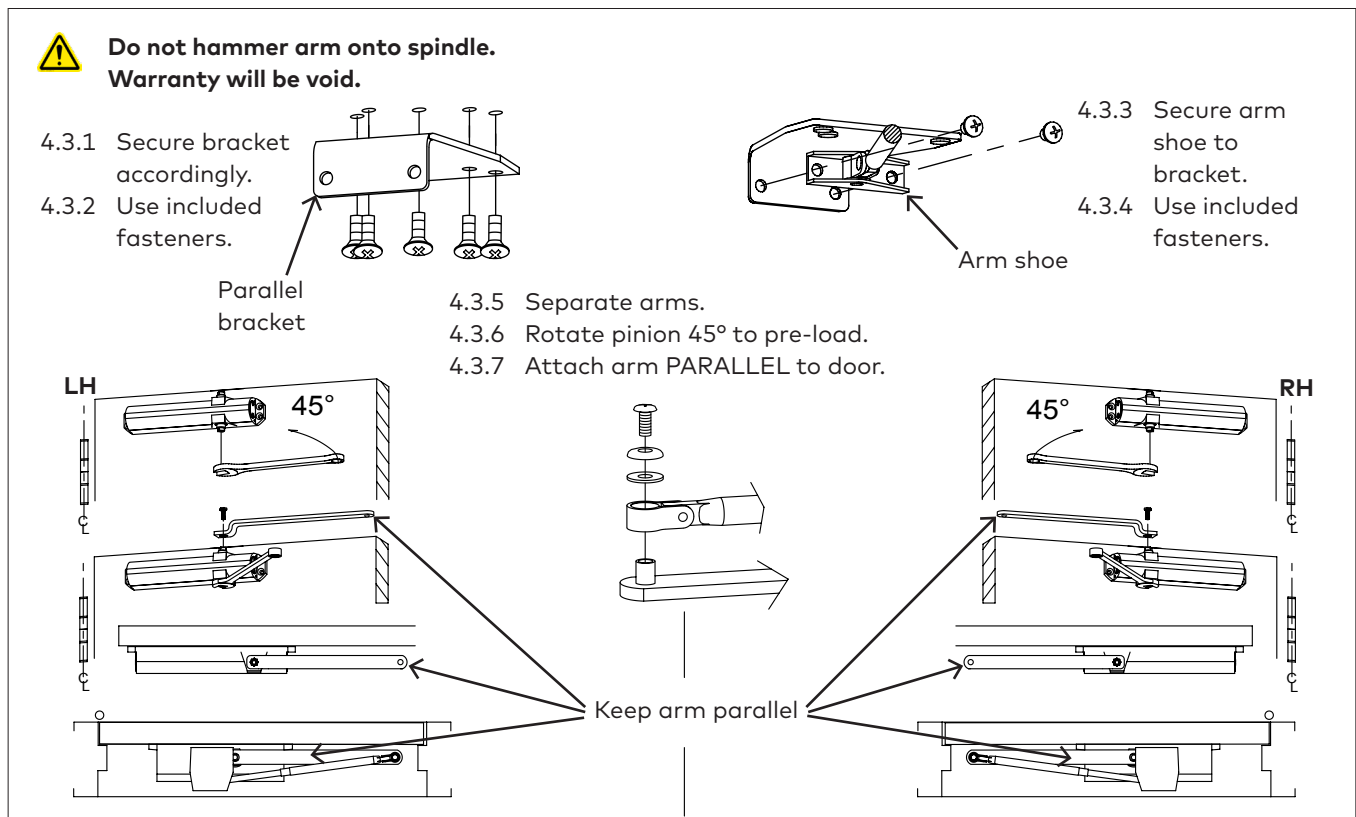

5 Adjustments

- ⚠ Confirm closer spring size prior to making any closing speed adjustments.
- ⚠ Do not back valve heads out beyond closer casting.
- ⚠ Backcheck positioning MUST be turned "ON" for parallel arm applications.
- ⚠ Backcheck position will advance approximately 15°.
- ⚠ Check delayed action (DA) function if supplied.
- ⚠ Maximum opening angle is 180°.
- ⚠ Door should close in 3 to 6 seconds from 90°.
- ⚠ Do not close valves completely.
- ⚠ Ball bearing hinges and pivots should always be used.
- ⚠ HD7016 meets 5lb interior barrier-free requirements. If necessary, adjust closer spring and test pull forces until proper forces are obtained.

5.1 Adjust closing speeds: sweep, latch, backcheck, delayed action if applicable

Fig.11

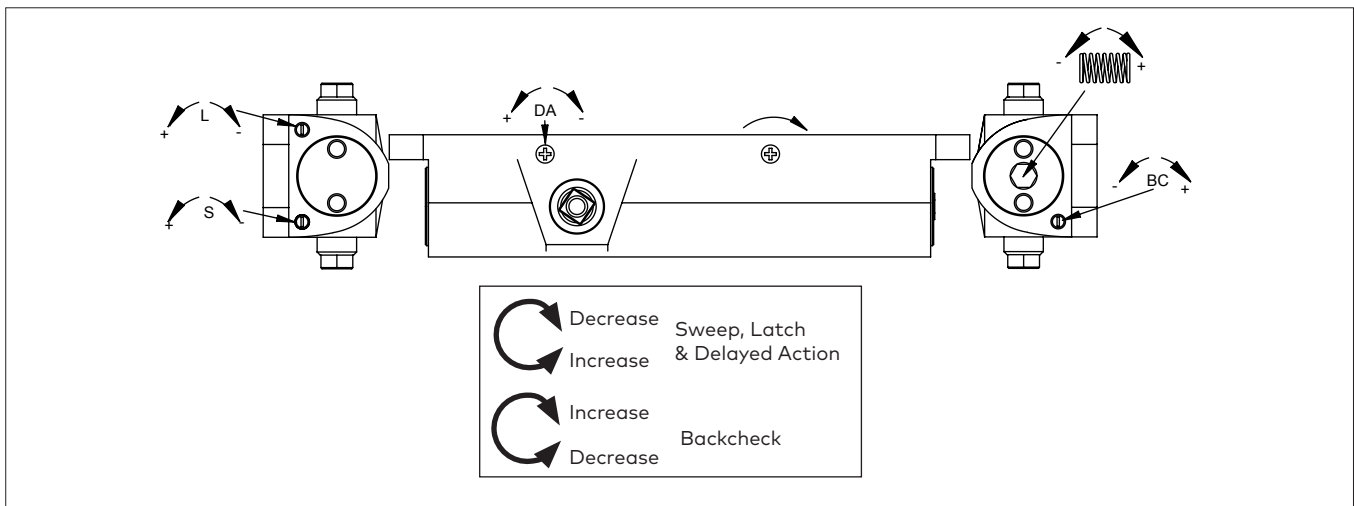

5.2 Adjust spring force

Fig.12

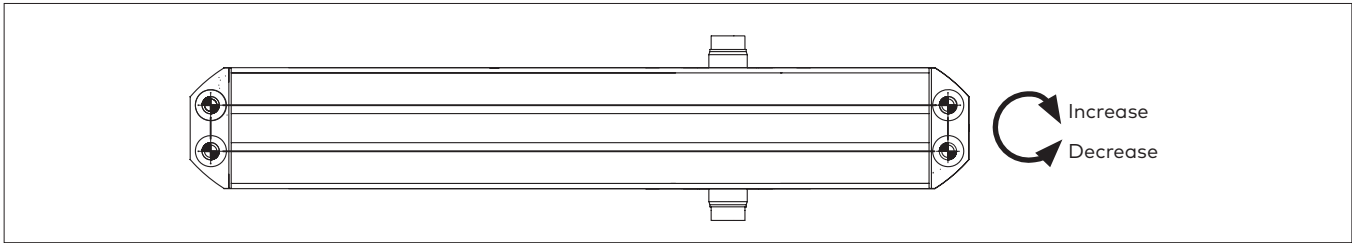

Regular and top jamb mounts					
	Closer size	Max door weight (lbs)	Door width		Full turns
			Interior	Exterior	
HD7016	2	100	2'6"	---	-19
	3	125	3'	2'6"	-11
	4	150	3'6"	3'	0
	5	200	4'	3'6"	+5
	6	250	---	4'	+13
Parallel mount					
HD7016	3	100	2'6"	----	-11
	4	125	3'	2'6"	0
	5	150	3'6"	3'	+5
	6	200	4'	3'6"	+13

6 Install covers

Fig.13

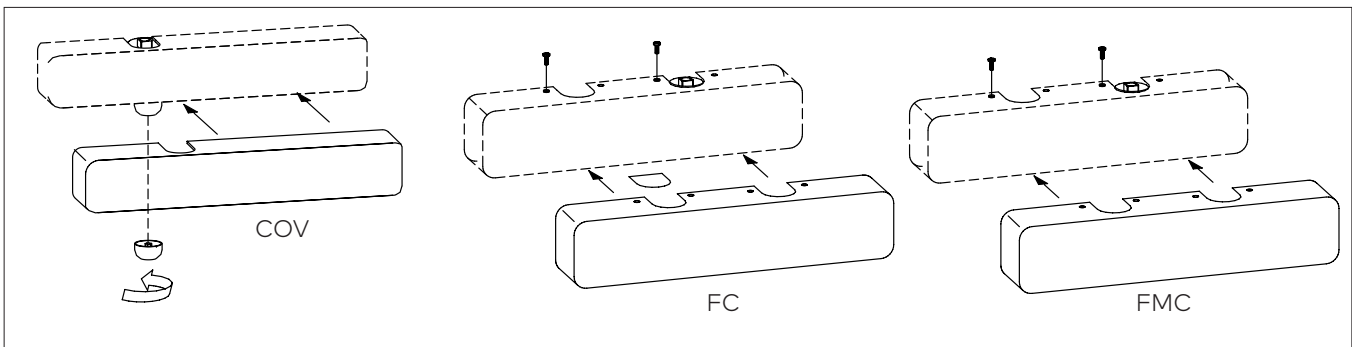

For Complete Online Instructions Visit:
<https://dhwsupport.dormakaba.com/hc/en-us>

For Assistance or Warranty Information:
 Call 1-800-392-5209 or visit
<https://dhwsupport.dormakaba.com/hc/en-us>