

STOP	STRIKE	CHASSIS BACKSET	MINIMUM STILE
5/8\" (16 mm) STOP	443	1 1/2\" (38 mm)	3 7/8\" (98 mm)
	430	2\" (51 mm)	4 1/4\" (108 mm)
	486, 463	2 1/8\" (54 mm)	4 7/16\" (113 mm)

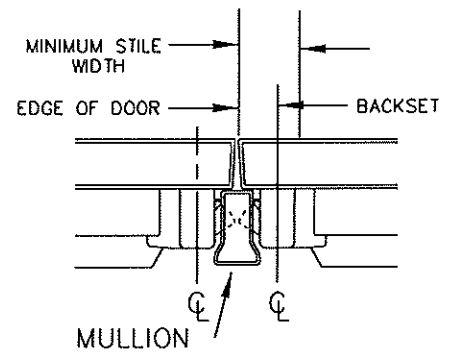

MULLION	STRIKE	CHASSIS BACKSET	MINIMUM STILE
1310	443	1 1/2\" (38 mm)	3 3/4\" (95 mm)
	430	N/A	N/A
	486, 463	2 1/8\" (54 mm)	4 3/8\" (111 mm)
1330	430	2 1/4\" (56 mm)	4 7/16\" (113 mm)
	486, 463	2 7/16\" (62 mm)	5 9/16\" (143 mm)
F1300	430	2 1/2\" (63 mm)	4 11/16\" (119 mm)
1340KR			
F1340KR	486, 463	2 11/16\" (68 mm)	4 13/16\" (122 mm)

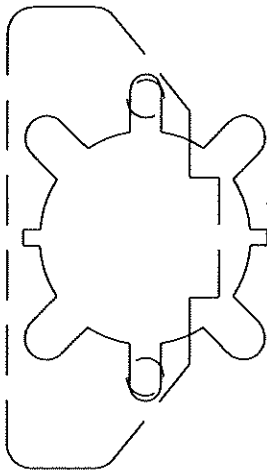

OPTIONAL SDI CUTOUT

NOT TO SCALE

NOTES:

1. SEE MASTER SHEET #T-0001 FOR SUGGESTED DOOR REINFORCEMENT.
2. SEE ADDITIONAL TRIM TEMPLATE WHEN REQUIRED.

NOTES:

1. Pairs of Doors using Mullions may not be prepped with ANA1 161.1 Door Prep.

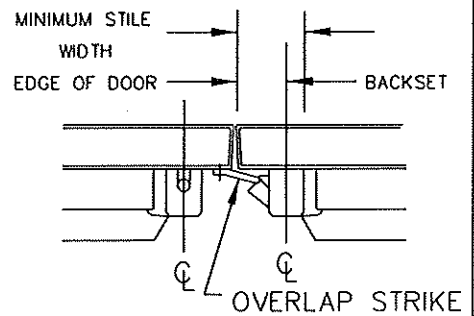

STRIKE	CHASSIS BACKSET	MINIMUM STILE
319/320	1 5/8\" (41 mm)	4 1/16\" (103 mm)

REV. No. 5

REVISION: CLARIFY BACKSET

DATE: 10-4-17



8300 & F8300 RIM TYPE EXIT DEVICE WHEN USED WITH  
 C03, R03, K03, C03IC, R03IC, K03IC KEY IN LEVER TRIM  
 C08, R08, K08, C08IC, R08IC, K08IC KEY IN LEVER TRIM  
 C23, R23, K23 LEVER TRIM

TEMPLATE NUMBER  
 T-10210 ©

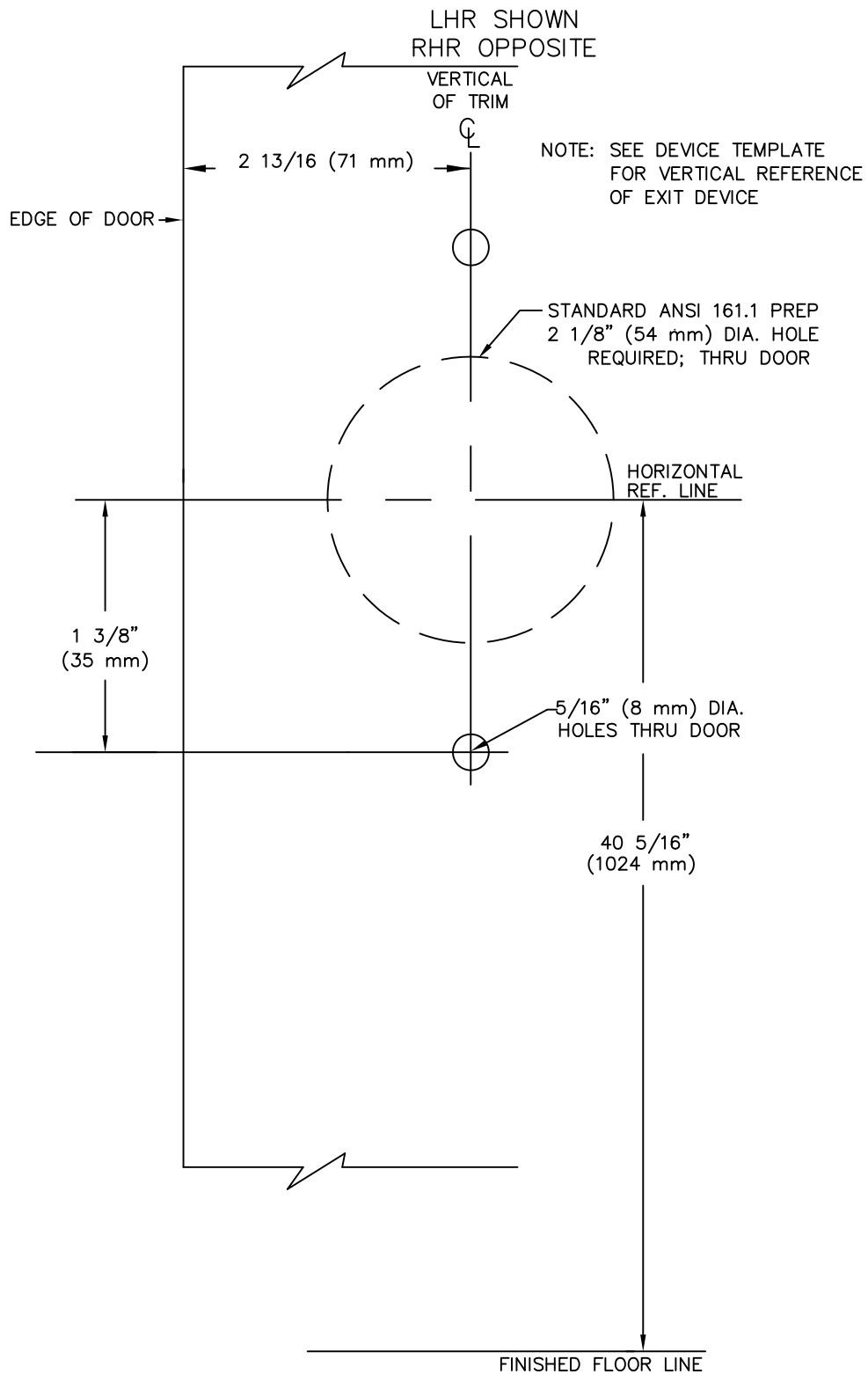

NOT TO SCALE

NOTES:

1. SEE MASTER SHEET #T-0001 FOR SUGGESTED DOOR REINFORCEMENT.

REV. No. 4

REVISION: Delete 9000 SERIES, now only 8000 SERIES

DATE: 11-05-2014



C,K,R02R, C,K,R03R/03RIC, C,K,R08/08IC, C,K,R23  
8000 SERIES LEVER TRIM

TEMPLATE NUMBER  
T-2066 ④