

RHR SHOWN
LHR OPPOSITE

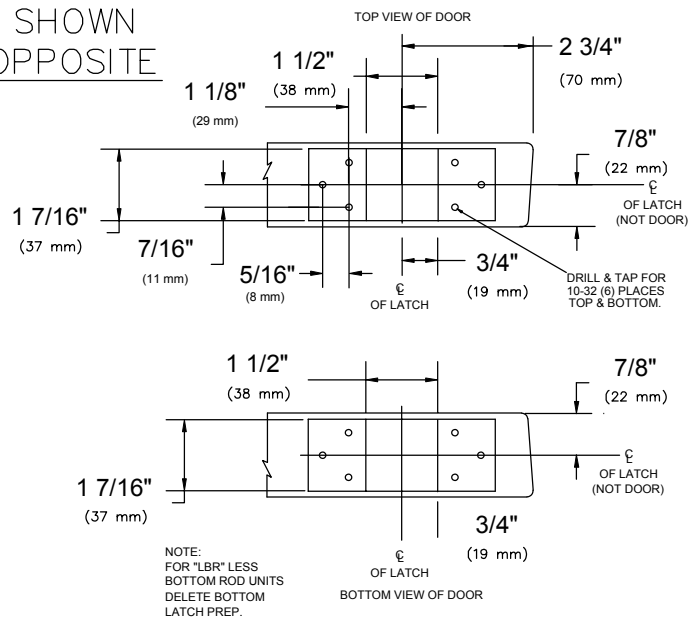

NOTE:
FOR "LBR" LESS
BOTTOM ROD UNITS
DELETE BOTTOM
LATCH PREP.

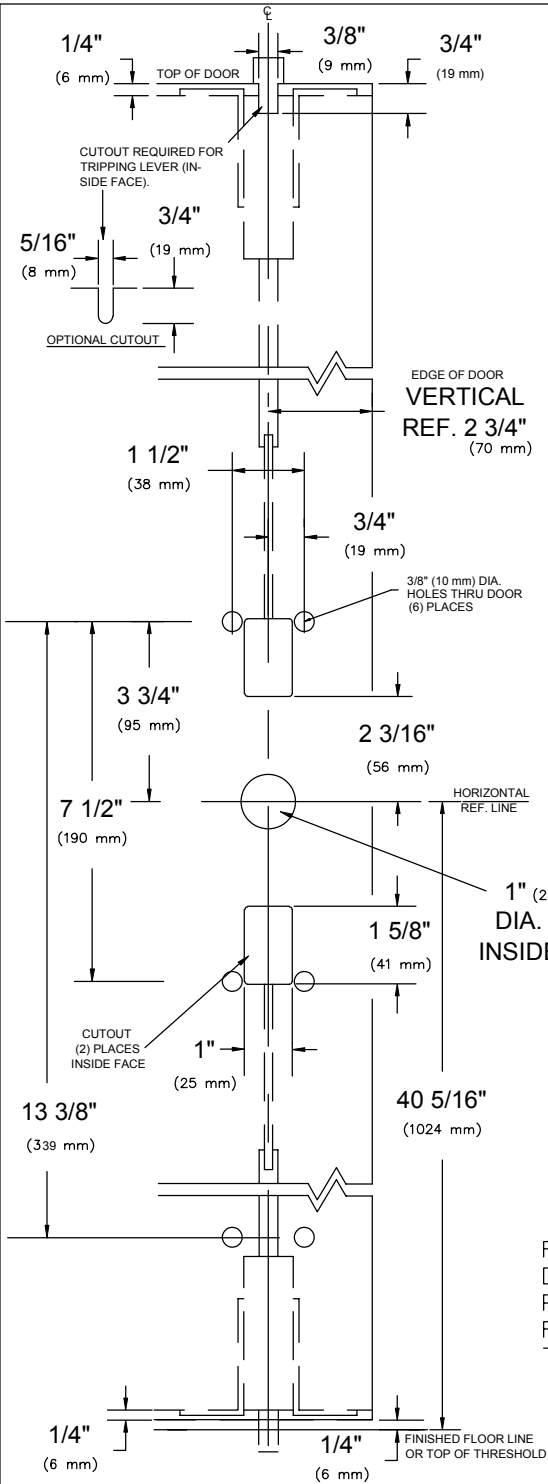
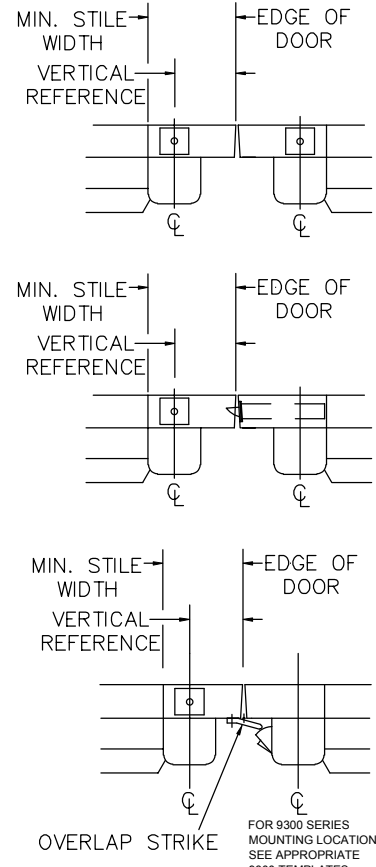

FOR LESS BOTTOM ROD (LBR)
DEVICES, DELETE BOTTOM LATCH
PREP. POPPER REQUIRED ON FIRE
RATED DEVICE, SEE TEMPLATE
T-4012.

NOTES:

1. SEE ADDITIONAL TRIM TEMPLATE WHEN REQUIRED.
2. DEVICE WILL COVER STANDARD SDI CUTOUT.
3. FOR SEX NUTS USE 3/8" DRILL.

VERTICAL REFERENCE	MINIMUM STILE WIDTH
2 3/4" (70 mm)	4 3/16" (106 mm)

REV. No. 6 REVISION: Dimension Correction DATE: 8-14-03



9100 & F9100 x HTT22CV or HRT22CV
9100 & F9100 x HTT05/06CV or HRT05/06CV
VERTICAL ROD EXIT DEVICE

TEMPLATE NUMBER
T-9106 ⑥

RHR SHOWN
LHR OPPOSITE

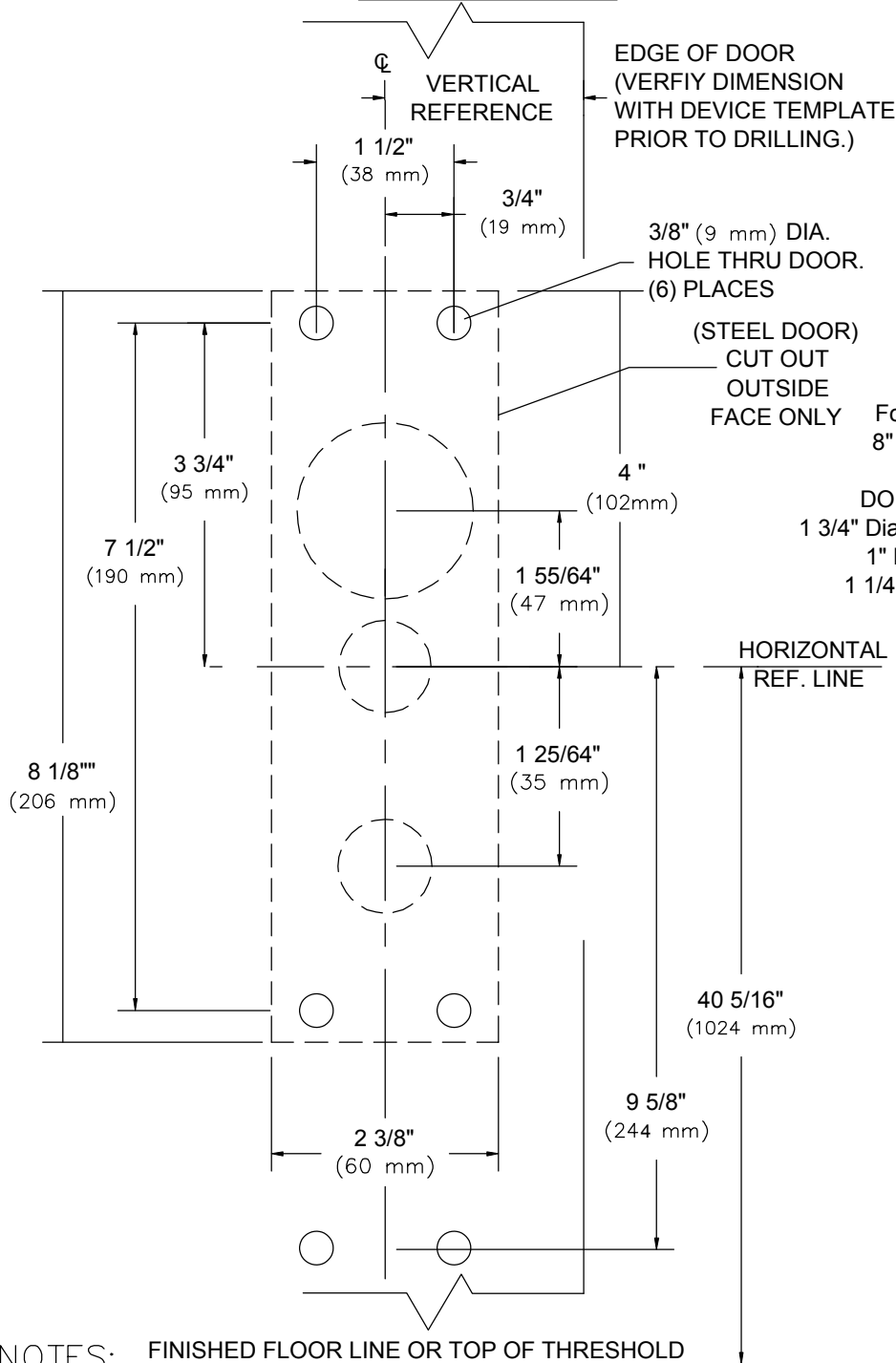

EDGE OF DOOR
(VERIFY DIMENSION
WITH DEVICE TEMPLATE
PRIOR TO DRILLING.)

3/8" (9 mm) DIA.
HOLE THRU DOOR.
(6) PLACES

(STEEL DOOR)
CUT OUT
OUTSIDE
FACE ONLY

For Wood or Composite Doors;
8" x 2 1/4" x 3/4" Deep Min. Cut
Out. (Outside Face)
DO NOT CUT THROUGH DOOR!
1 3/4" Dia. Min. Hole x 1 1/4" Deep As Shown
1" Dia. Min. Hole Thru As Shown
1 1/4" Dia. Hole x 1" Deep As Shown

HORIZONTAL
REF. LINE

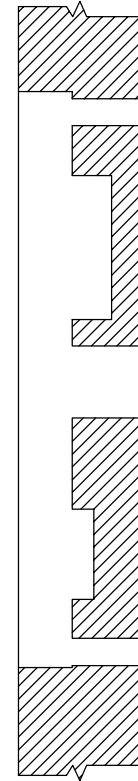

NOT TO
SCALE

NOTES: FINISHED FLOOR LINE OR TOP OF THRESHOLD

1. SEE MASTER SHEET #T-0001 FOR SUGGESTED DOOR REINFORCEMENT.
2. SEE ADDITIONAL DEVICE TEMPLATE WHEN REQUIRED.
3. TRIM WILL COVER STANDARD SDI CUTOUT.

REV. No. 6

REVISION: Dimension Update

DATE: 8-14-03



HTT22CV or HRT22CV
HTT05/06CV or HRT05/06CV
TRIM

TEMPLATE NUMBER

T-9016 ©