

NOTE:

1. DO NOT SCALE DRAWING.
2. DIMENSIONS ARE IN INCHES\ (MM).
3. MIN. HEADER SIZE 1-3/4" X 4"
4. CUT OUT FOR COVER PLATE
3-3/4" X 15-3/4".
5. CLEARANCE BETWEEN HEADER AND DOOR 1/8".
6. 90° HO MODELS NOMINAL HOLD OPEN AT 88°.
105° HO MODELS NOMINAL HOLD OPEN AT 103°.
7. AUXILIARY STOP REQUIRED COINCIDING WITH DEADSTOP ON RTS CLOSER.

FOR 8-32 MACHINE SCREWS USE No.29 (0.136")
DRILL AND TAP THREE (3) HOLES

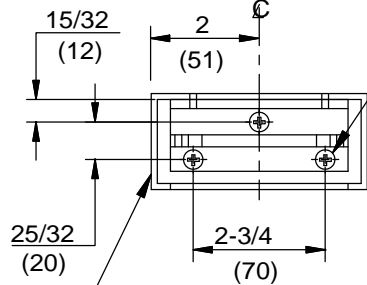

PIVOT SIDE

SIDE VIEW
(CLOSER BODY REMOVED)

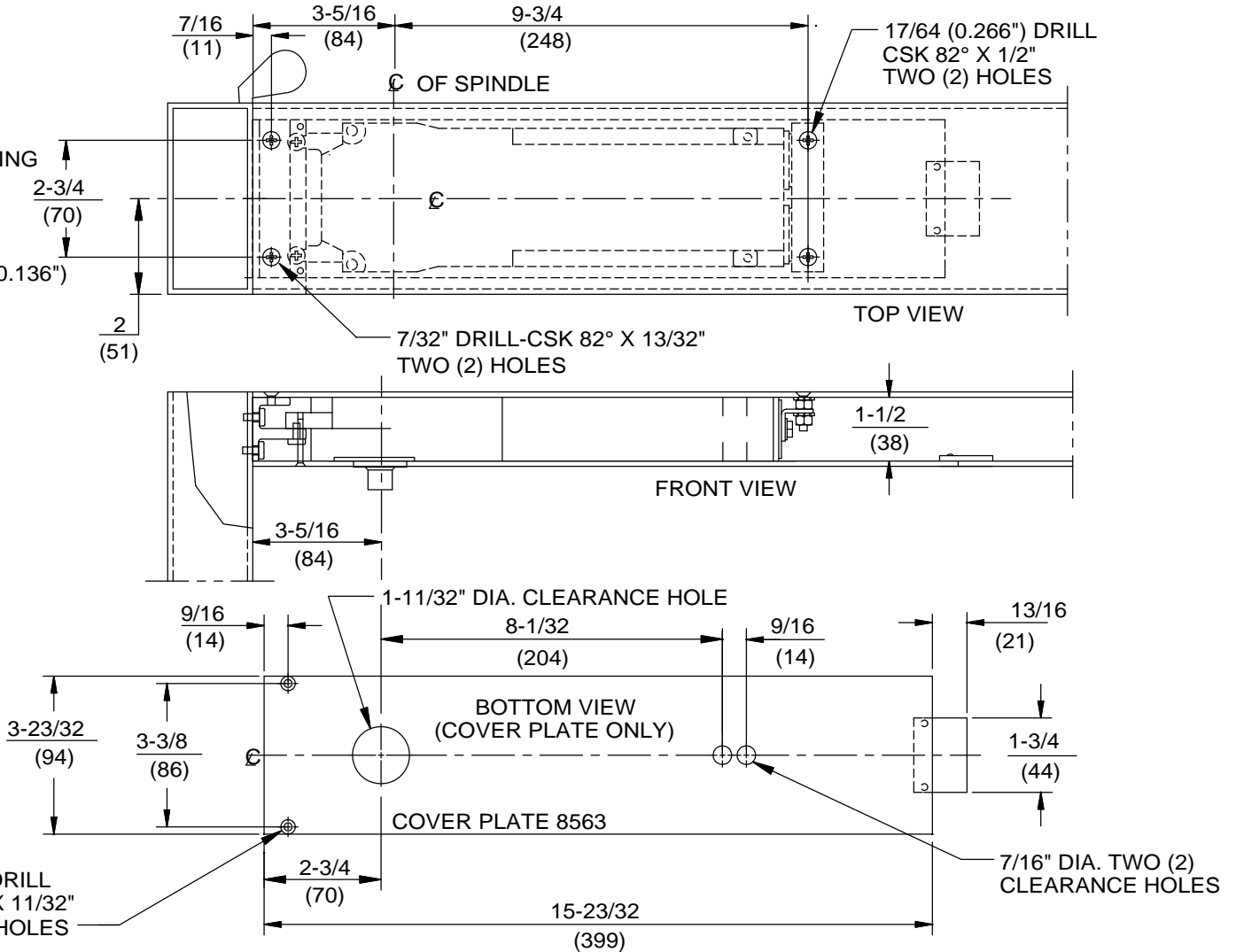

Always consult Dorma's web site for latest template at www.dorma-usa.com or call 1-800-523-8483.

DOOR CLOSER MODEL: RTS SERIES PACKAGE 26, ALUMINUM DOOR AND FRAME PREPARATION, No. 8812 TRACK ARM, No. 8563 COVER PLATE, DOOR HUNG ON 3/4" OFFSET PIVOTS



DORMA Door Controls
Reamstown, PA 17567

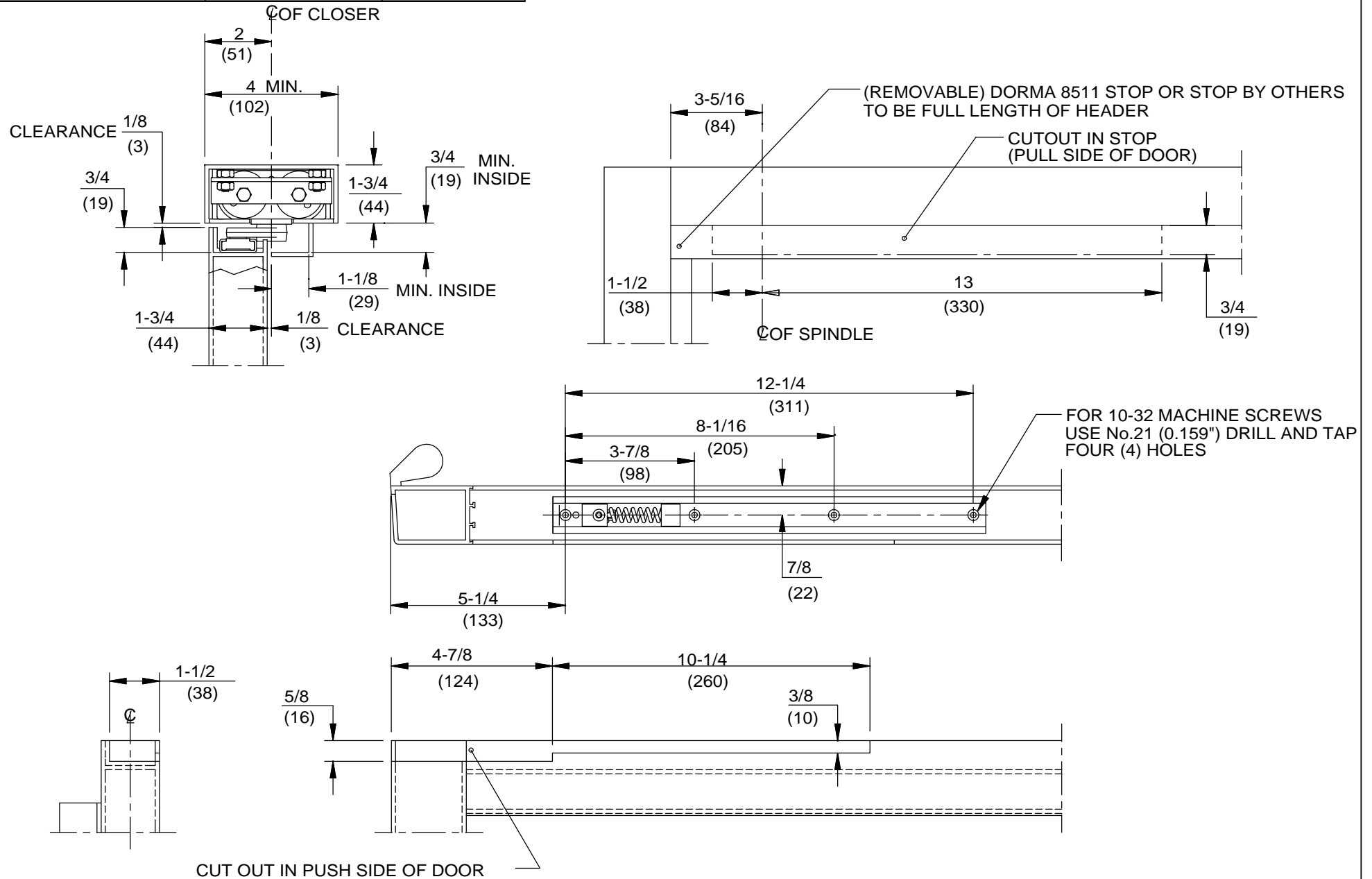

Always consult Dorma's web site for latest template at www.dorma-usa.com or call 1-800-523-8483.



DORMA Door Controls
 Reamstown, PA 17567