

RTS SERIES PACKAGE 27 OFFSET SLIDE ARM STEEL DOOR AND FRAME - HINGES /PIVOTS

1. PREPARE FRAME AND INSTALL CLOSER

NOTE: 8532 mounting channel is to be installed prior to frame installation.

Prepare header (1) according to template. Fasten angle bracket (2) to closer (3) with two hex head machine screws and flat washers. Install two fillister head machine screws (4) into mounting tabs on closer, make approximately three turns.

Install closer into mounting channel (5) in header by inserting mounting tabs into mounting bracket. Then raise end of closer with angle bracket onto the two 1/4-20 screws installed in mounting channel. Fasten angle bracket with the two remaining lock washers and nuts (6). Tighten the two fillister head machine screws -- SECURELY!

Install cover plate (7) by sliding tab into frame and fasten opposite end to mounting bracket with two No. 8-32 flat head machine screws.

2. PREPARE TOP OF DOOR ACCORDING TO TEMPLATE

Assemble shock spring (8). Slide assembled shock spring into track (9) so end with screw faces the 90° and 105° markings on the track. Align edge of shock spring assembly to coincide with 90° or 105° deadstop in closer (SEE ILLUSTRATION "A"). Secure shock spring assembly to track with button head machine screw (10) and 1/8" hex wrench. Insert slide block pin (11) through slide block (12) before inserting slide block into track. Fasten track to door with four No. 10-32 flat head machine screws (13). Slide arm (14) onto spindle as shown, and tighten the 1/4-20 socket head cap screw (15) securely.

Position door at approximately 45° of opening. Preload arm to a position where the hole in arm aligns with slide block pin. Thread slide block pin into arm with 3/16" hex wrench. **TIGHTEN SECURELY!**

3. ADJUST CLOSING SPEEDS

Valve "A" - Controls closing speed from maximum opening angle to 0°. Clockwise turns decrease closing speed, counterclockwise turns increase closing speed.

Valve "B" - Increases closing speed from maximum opening angle to 20°, turn valve counterclockwise.

4. INSTALL OPTIONAL 8511 APPLIED STOP (OR STOP BY OTHERS)

Prepare header according to template below. Install applied stop (16) as shown with three No. 10-32 flat head machine screws.

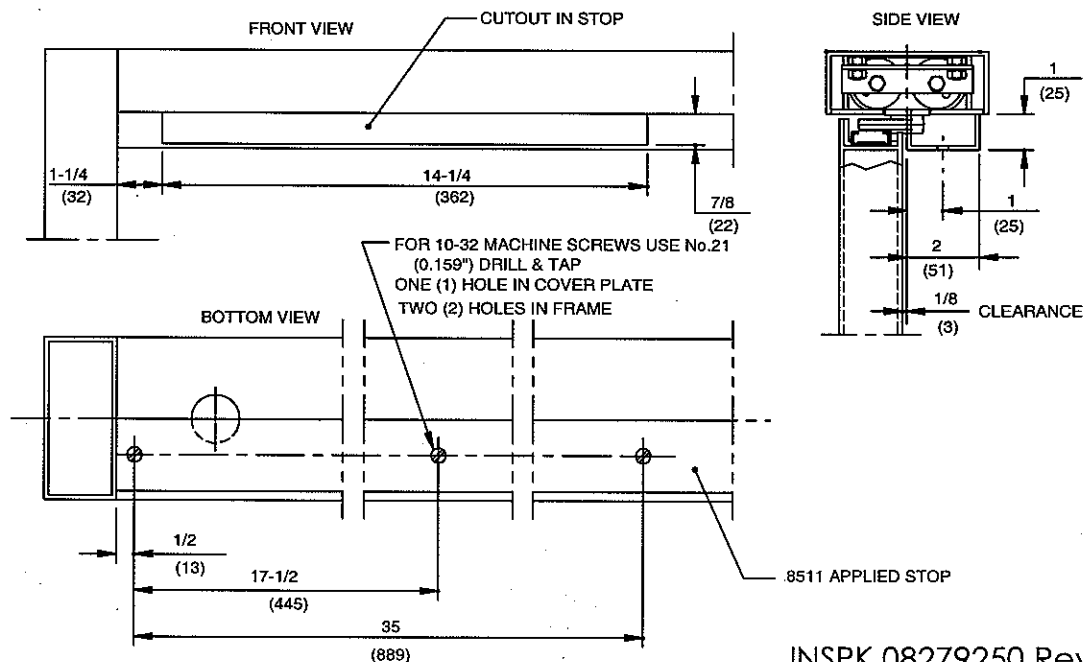

INSPK 08279250 Rev.03/06

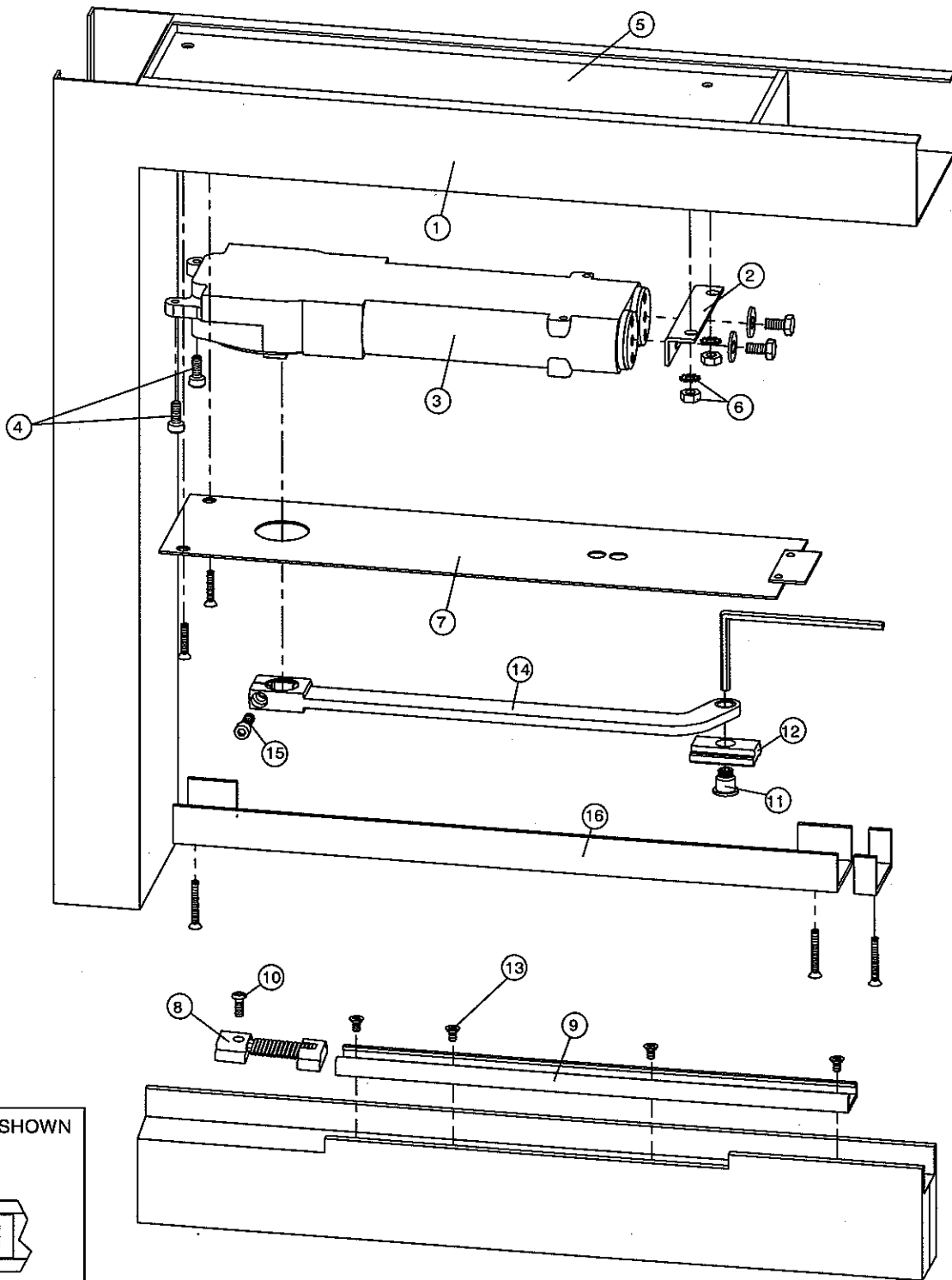

90° SHOCK SPRING SETTING SHOWN

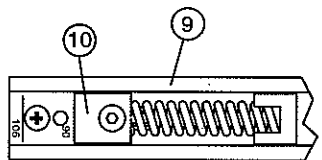

(ILLUSTRATION "A")

