

NOTES:

1. DRAWING IS NOT TO SCALE.
2. DIMENSIONS ARE IN INCHES/[MM].

WOOD DOORS FOR:
C310, C330, C340, C353
FACE PLATE 1" FLAT OR BEVELED
RADIUS CORNERS

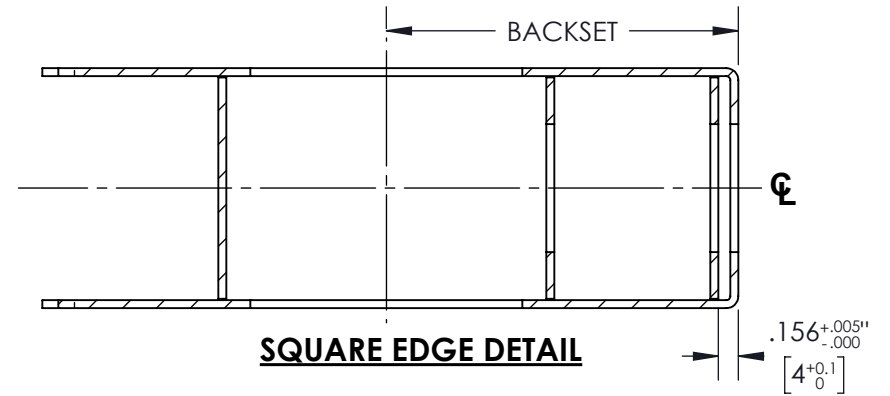
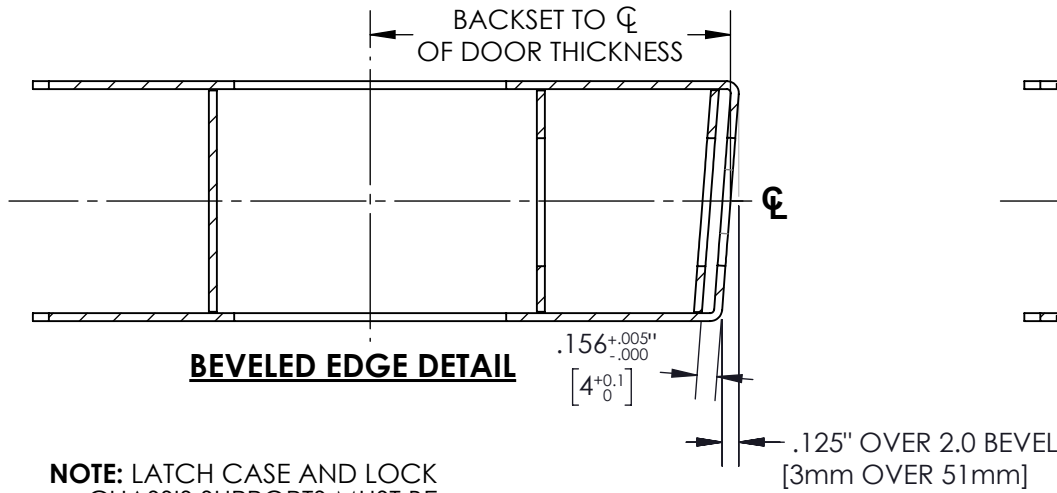

NOTE: LATCH CASE AND LOCK CHASSIS SUPPORTS MUST BE DESIGNED TO PROVIDE ADEQUATE STRENGTH TO SUPPORT THE LOCK WITHOUT CRUSHING THE DOOR.

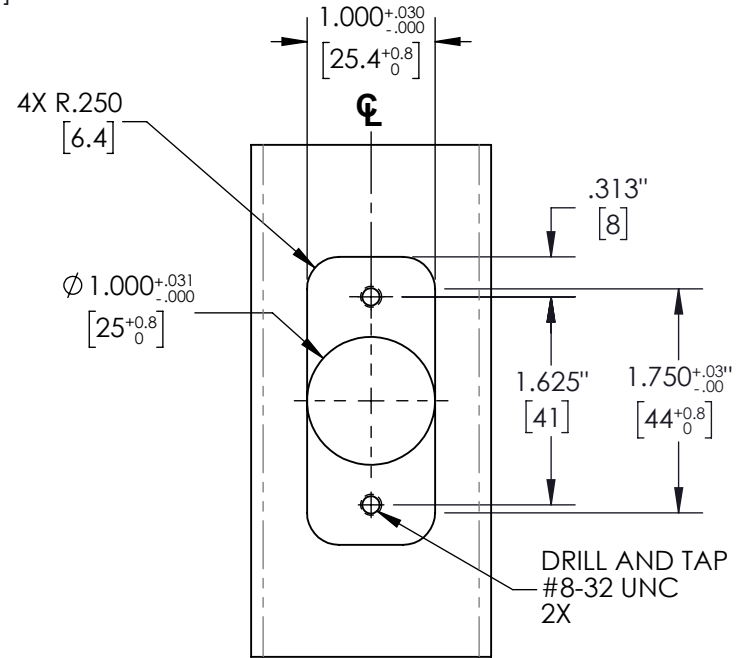
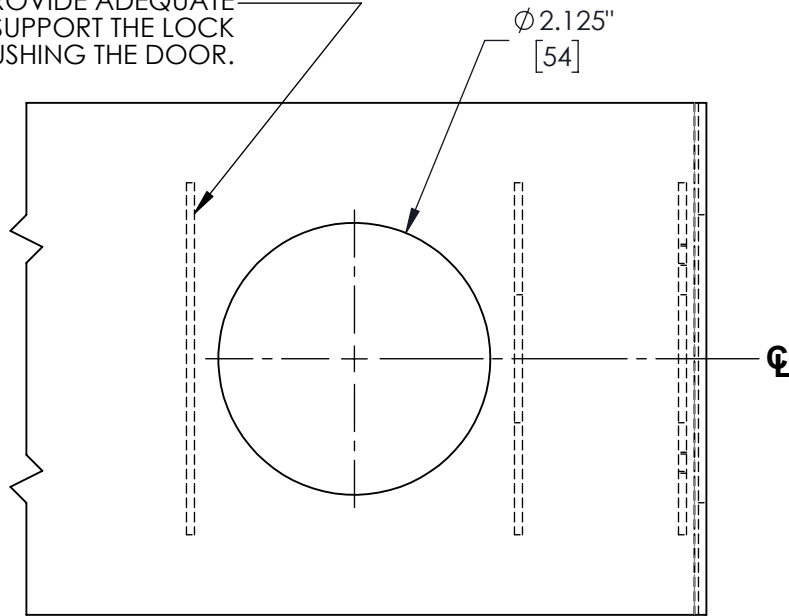

NOTES:

1. DRAWING IS NOT TO SCALE.
2. DIMENSIONS ARE IN INCHES/[MM].

METAL DOORS FOR:
C310, C330, C340, C353
FACE PLATE 1" FLAT OR BEVELED
RADIUS CORNERS