

NOTES:

1. DRAWING IS NOT TO SCALE.
2. DIMENSIONS ARE IN INCHES/[MM].

WOOD DOORS FOR:
C310, C330, C340, C353
FACE PLATE 1-1/8" FLAT OR BEVELED

DORMA USA, Inc.
Reamstown, PA 17567

Toll-Free: (800) 523-8483
Facsimile: (800) 274-9724

Always consult DORMA's web site for latest
template at www.dorma.com.

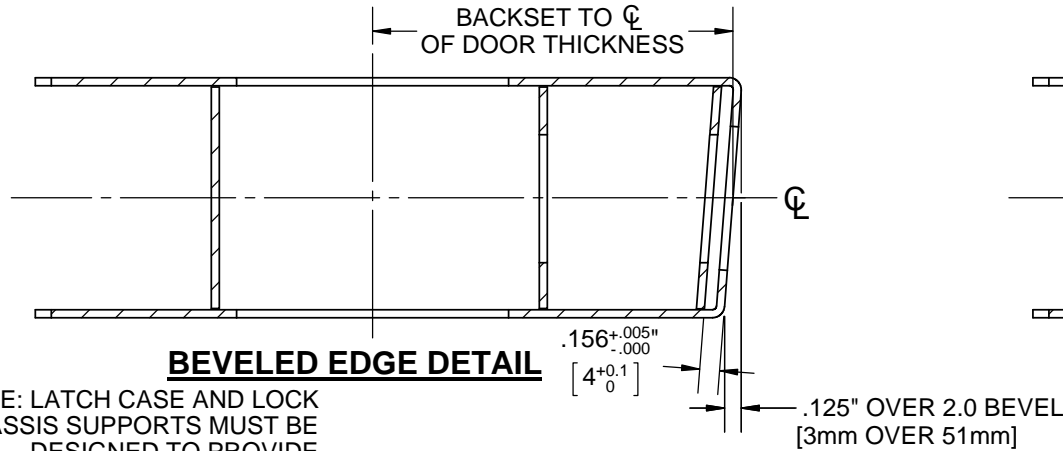

BEVELED EDGE DETAIL

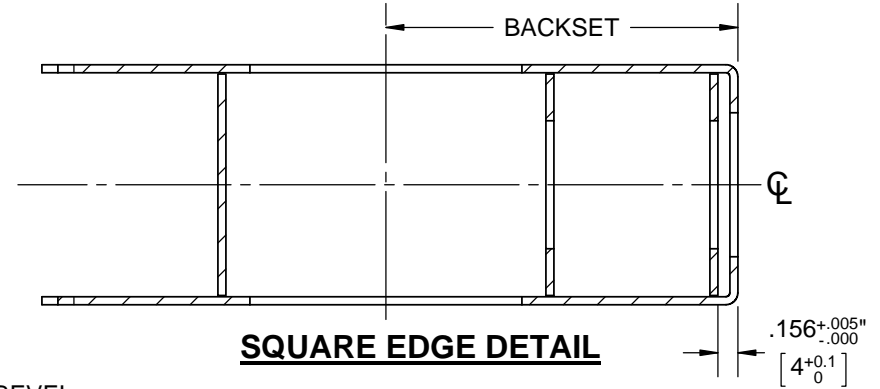

SQUARE EDGE DETAIL

NOTE: LATCH CASE AND LOCK CHASSIS SUPPORTS MUST BE DESIGNED TO PROVIDE ADEQUATE STRENGTH TO SUPPORT THE LOCK WITHOUT CRUSHING THE DOOR.

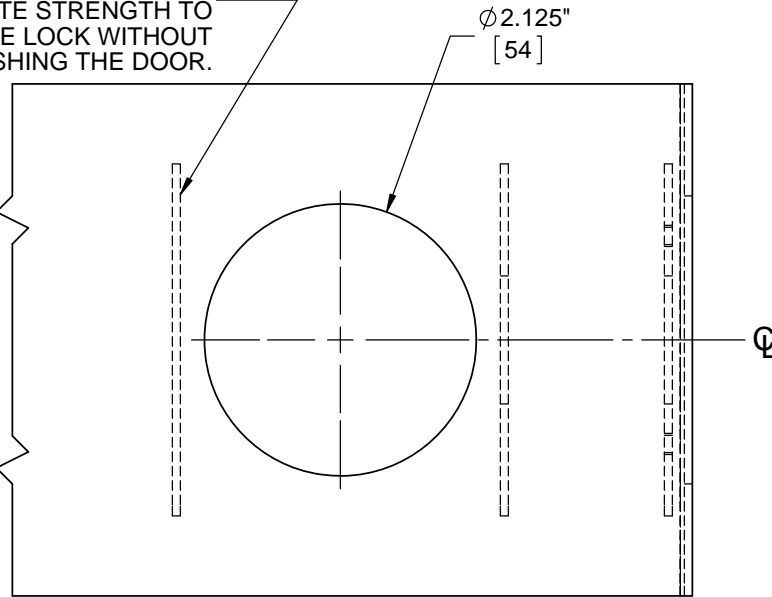

DOOR FACE DETAIL

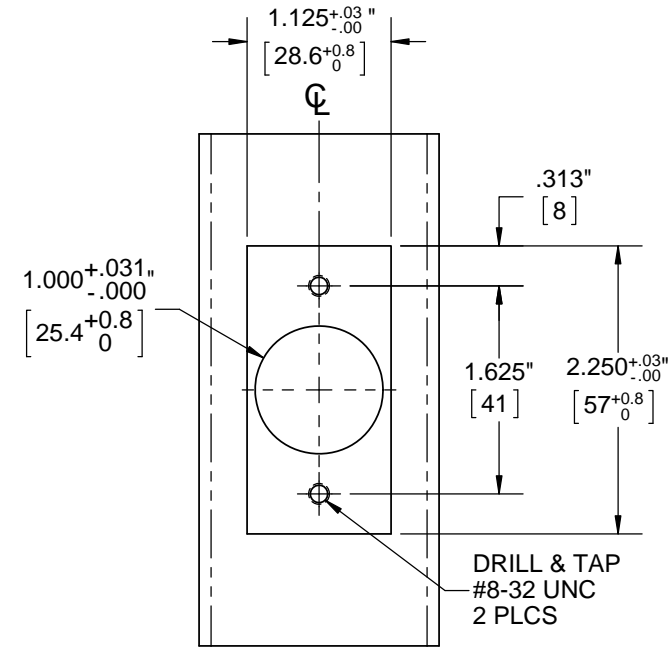

DOOR EDGE DETAIL

NOTES:

1. DRAWING IS NOT TO SCALE.
2. DIMENSIONS ARE IN INCHES/[MM].

METAL DOORS FOR:
C310, C330, C340, C353
FACE PLATE 1-1/8" FLAT OR BEVELED

DORMA USA, Inc.
Reamstown, PA 17567

Toll-Free: (800) 523-8483
Facsimile: (800) 274-9724

Always consult DORMA's web site for latest template at www.dorma.com.