

No.	REVISIONS	DATE
2	REDRAWN ON CAD	08/27/97

TOP VIEW

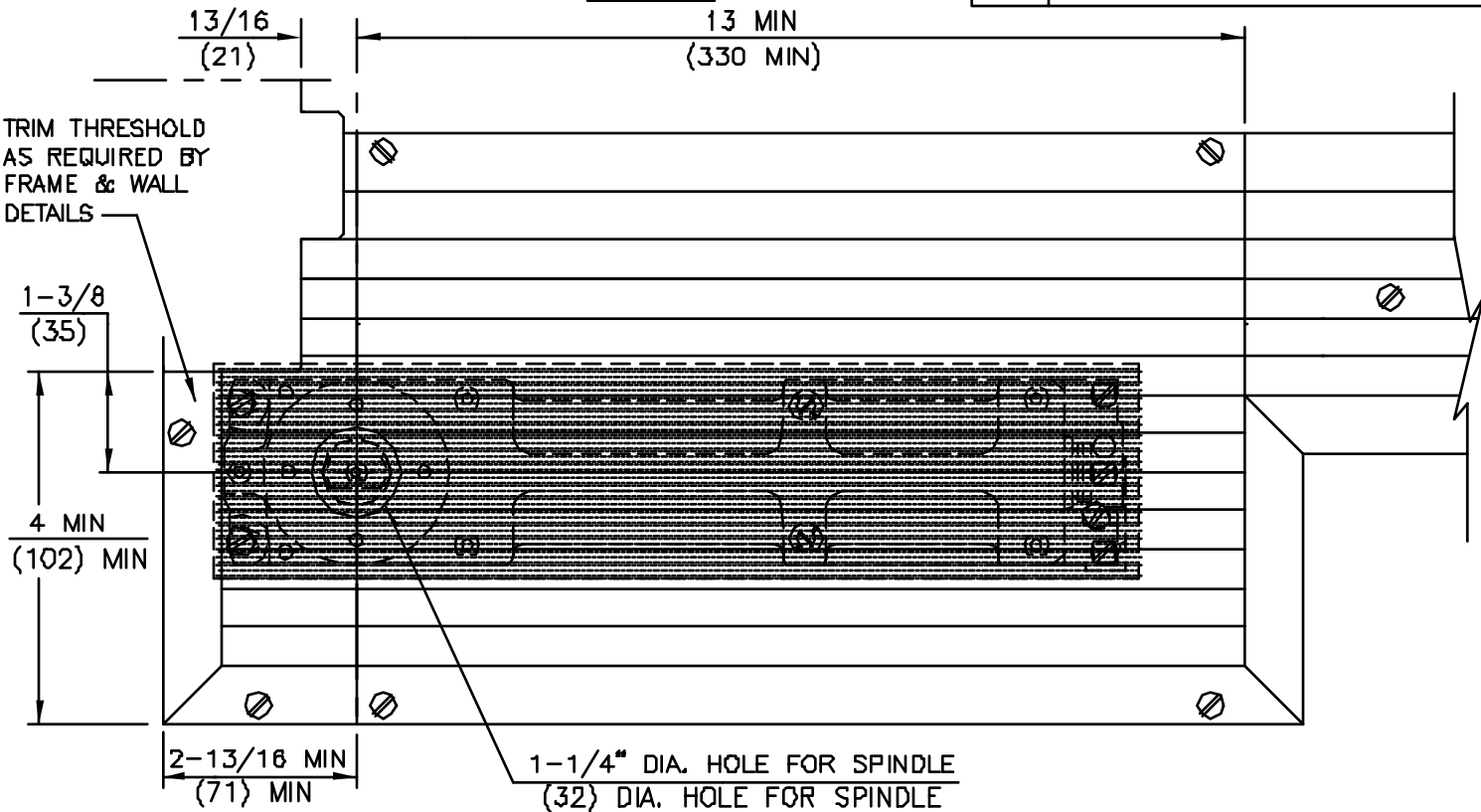

NOTES

1. DO NOT SCALE DRAWING.
2. DIMENSIONS ARE IN INCHES/(mm).
3. TOP OF CEMENT CASE MUST BE FLUSH WITH FINISH FLOOR LINE.
4. CEMENT CASE MUST BE LEVEL AND PARALLEL TO FRAME.
5. SEALING COMPOUND SC1 IS HIGHLY RECOMMENDED FOR EXTERIOR DOORS

SIDE VIEW

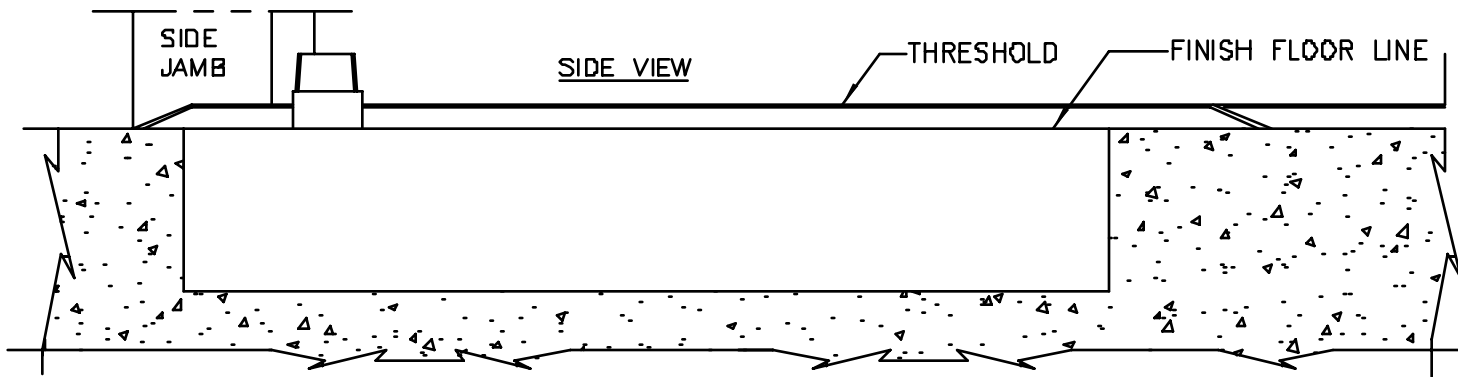

FLOOR CLOSER MODELS: BTS SERIES 1-1/2" OFFSET THRESHOLD PREPARATION



DORMA Architectural Hardware
 REAMSTOWN, PENNSYLVANIA 17567
 TEMPLATE No. BTS-27 (2)
 SIDE 1 OF 2

THRESHOLDS IN CONJUNCTION WITH
BTS SERIES 1-1/2" OFFSET FLOOR CLOSER

THREE PIECE REMOVABLE THRESHOLDS ARE REQUIRED OVER THE CLOSER, TO ALLOW ACCESS TO THE SWEEP AND LATCH VALVES.

THRESHOLD CAN NOT BE ATTACHED DIRECTLY TO THE CLOSER BODY, AS IT IS ADJUSTABLE WITHIN THE CEMENT CASE.

THRESHOLD MUST BE FASTENED ON BOTH SIDES OF THE CEMENT CASE BY USE OF LAGS OR A SIMILAR METHOD. THIS WILL ALLOW REMOVAL OF THE CENTER THRESHOLD SECTION TO GAIN ACCESS TO THE CLOSER.

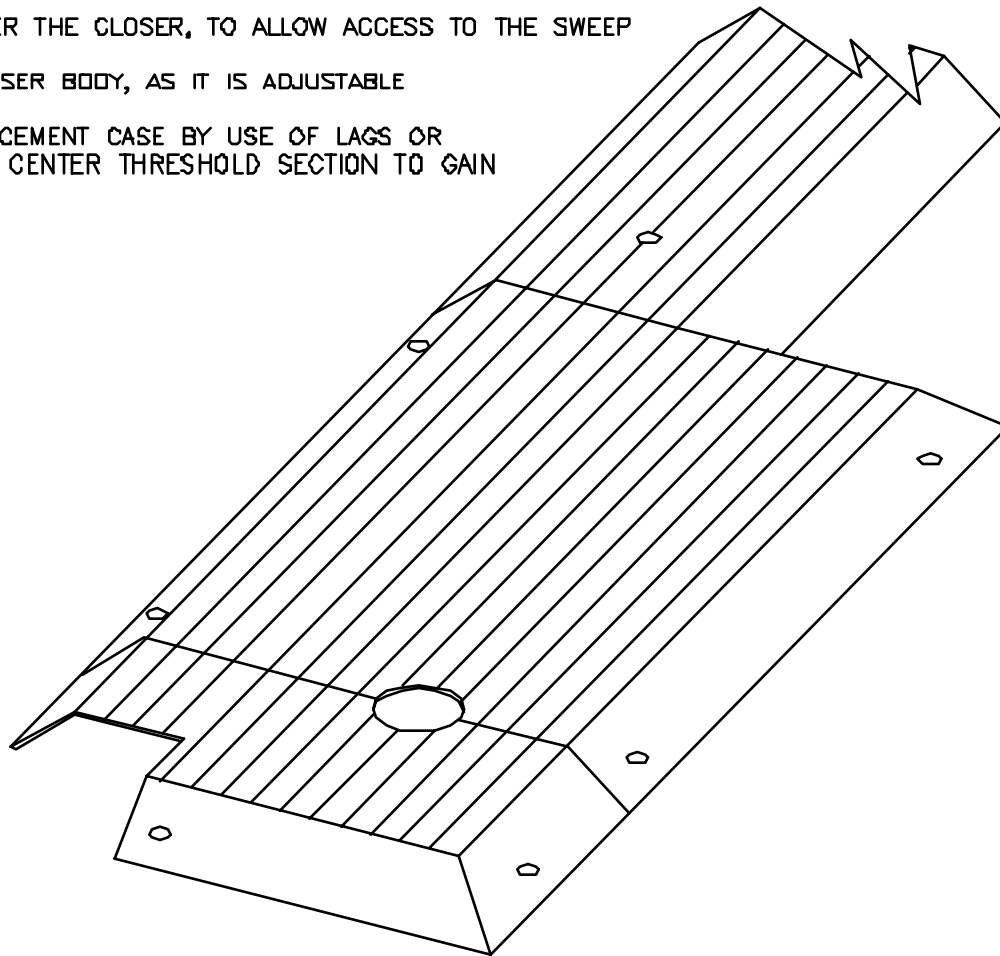

DORMA DOOR CONTROLS INC.
REAMSTOWN, PENNSYLVANIA 17567
TEMPLATE No. BTS-27 ②
SIDE 2 OF 2

ALWAYS CONSULT DORMA'S WEB SITE FOR LATEST TEMPLATE AT WWW.DORMA-USA.COM OR CALL 1 800 523 8483