

# BTS 75V/A,G, 75V BF/A,G, 80/A,G CENTER HUNG PACKAGES

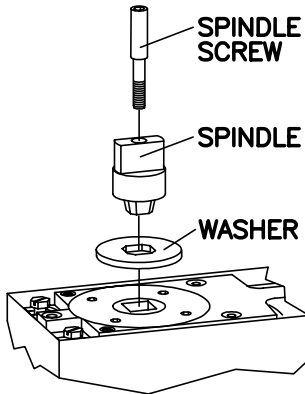

## 1 Attach spindle to closer.

Slide washer over tapered square end of spindle until fully seated in groove. Fasten spindle with spindle screw provided. **Tighten securely with 5mm HEX KEY.**

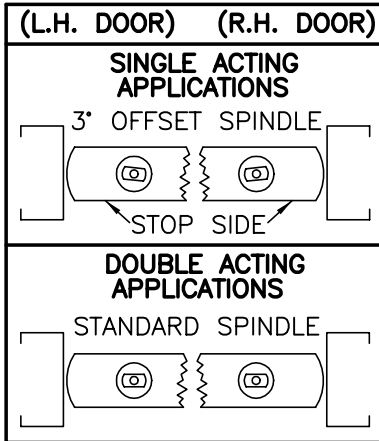

**CRITICAL** — WASHER MUST BE INSTALLED

## 2 Center closer in cement case. Tighten fastening screws.

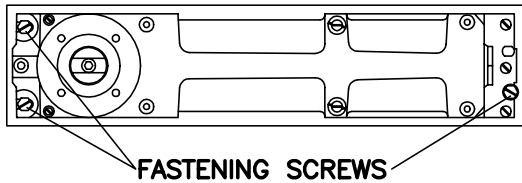

## 3 Install closer and cement case in floor.

Top of cement case must be flush with finished floor. Cement case must be level and installed parallel to frame. Spindle center line must be accurately located. Grout cement case in place.

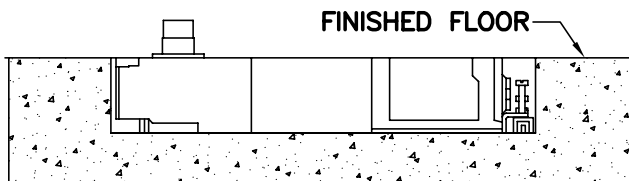

## 4 Determine clearance between door and frame and adjust projection of pivot pin, if required. Pivot pin projection allows 1/8" clearance as shipped from the factory.

To change projection of pivot pin or to install (8062 EXT PIN) extended pivot pin, the following is recommended:

Remove walking beam pivot screw. Push pivot pin out until walking beam is disengaged. Install extended pivot pin and engage walking beam into appropriate hole in pivot pin to obtain required projection. Be sure opposite end of walking beam is engaged in adjustment screw. Reinstall walking beam pivot screw.

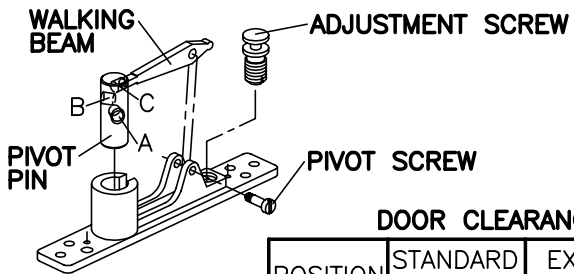

DOOR CLEARANCE

POSITION	STANDARD PIN	EXTENDED PIN
A	1/8"(3)	3/4"(19)
B	3/8"(10)	1"(25)
C	3/4"(19)	1-5/16"(33)

## 5 Retract pivot pin by turning adjustment screw counterclockwise and install pivot into header. Install cover plate.

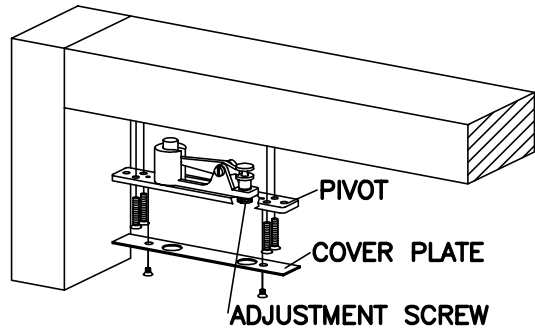

## 6 Fasten pivot channel in top of door. Place bearing insert into pivot channel. Turn adjustment screw approximately halfway into pivot channel. Adjust pivot point accordingly. Lock bearing insert in place with set screw.

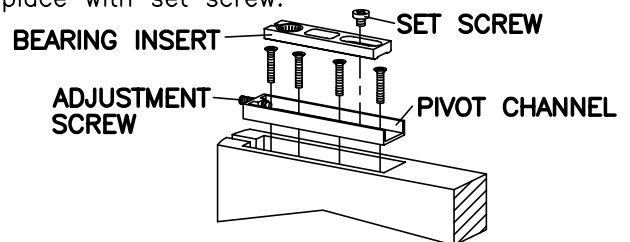

**7** Install bottom arm #7422.

Install four lateral support screws in arm. Turn in screws completely. Fasten arm to door with four pan head machine screws. Secure end of arm with flat head machine screw. Turn the four lateral support screws counterclockwise until head of screws firmly contact door.

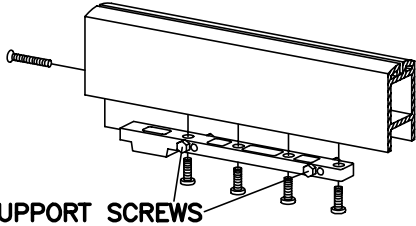

LATERAL SUPPORT SCREWS

**8** Install door.

With door parallel to frame, place bottom arm onto spindle. Rotate door approximately 90°. Align bearing with pivot pin. Engage pivot pin by turning adjustment screw clockwise. Check to make sure pivot pin is fully engaged in door portion of pivot.

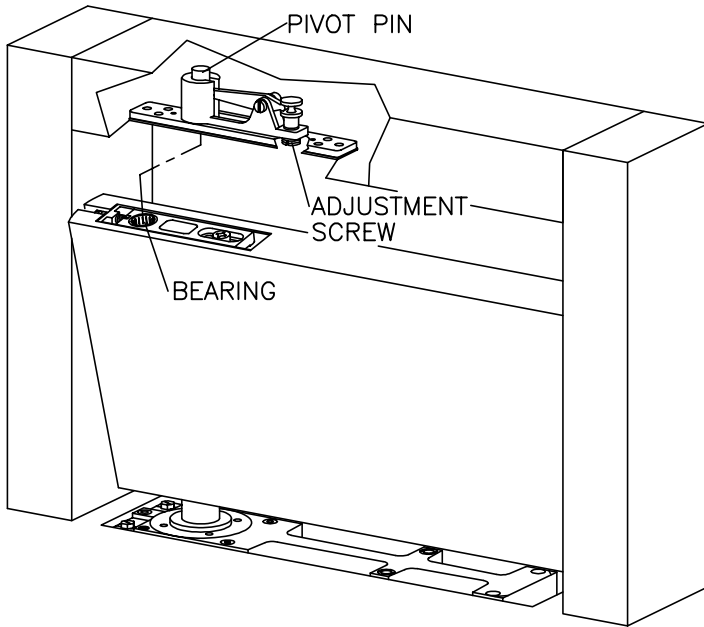

**9** Adjust bottom door clearances. (If necessary)

Closer can be raised approximately 5/32" within the cement case. Loosen fastening screws "A". Turn height adjustment screws "B" clockwise until desired height is obtained. **Closer must remain level!** Re-tighten fastening screws "A". **If more clearance is necessary, change spindle to appropriate size.**

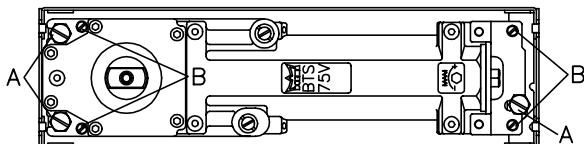
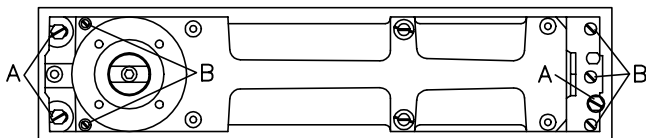

**10** Adjust closing speed.



**BTS 80**

**VALVE "D"**— controls closing speed from MAX. OPENING—80°.

**VALVE "E"**— controls closing speed from approx. 80°—0°.

**DELAYED ACTION:** Turn valve "D" clockwise until desired delay time is obtained.

**HOLD OPEN:** Turn valve "D" completely clockwise. Door will hold at any point beyond approx. 80°. Allow for approx. 4" fall away when considering hold open position. To release door, manually pull door closed a few inches.

**VALVE "C"**— controls position at which hold open or delayed action will begin to occur. Clockwise turns increase angle (105° max.). Counterclockwise turns decrease angle (75° min.).

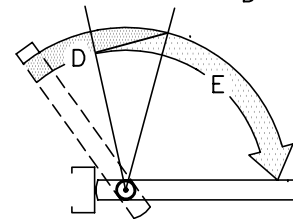
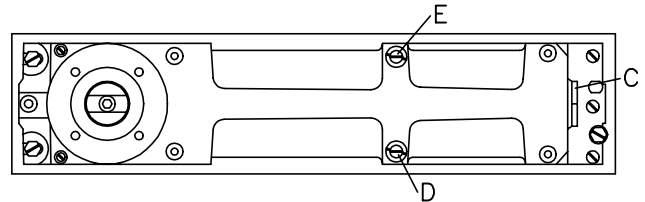

**BTS 75V**

**VALVE "D"**— controls closing speed from MAX. OPENING—15°.

**VALVE "E"**— controls closing speed from approx. 15°—0°.

**BTS 75V BF**

**VALVE "D"**— controls closing speed from MAX. OPENING—70°.

**VALVE "E"**— controls closing speed from approx. 70°—0°.

**DELAYED ACTION :** Turn valve "D" until desired delay time is obtained

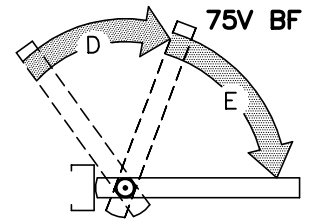
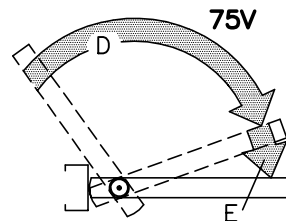
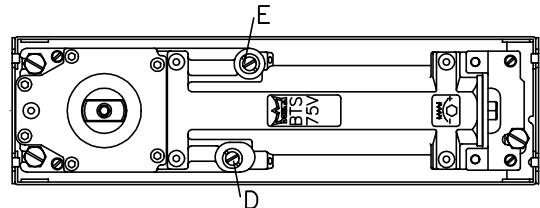

**HOLD OPEN :** Mechanical hold open is available at 90° or 105° as an option when ordering closer.

- 11 **BTS 75V/75V BF ONLY.**  
Adjust spring tension, if required.

**CRITICAL**

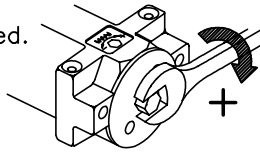

BTS75VBF—Adjust only if more spring tension is required to positively close and latch the door. Depending on opening conditions, a door adjusted to meet barrier-free forces may not have sufficient power to reliably close and latch the door.

BTS75V—Adjust according to chart.

BTS75V	DOOR WIDTH				FULL TURNS OF SPRING ADJUSTING NUT
	EXTERIOR		INTERIOR		
	INCHES	(MM)	INCHES	(MM)	
	—	—	2'-6"	762	3
	2'-6"	762	3'-0"	914	6
	3'-0"	914	3'-6"	1067	10

**NOTE: "MAX. 12 TURNS FROM MINIMUM SETTING".**

- 13 Install cover plate or threshold.

Trim cover plate as required to match profile of pivot jamb. Install cover plate with four screws provided. Press tab in place behind spindle. If threshold is installed, do not anchor threshold to closer body since closer is adjustable within cement case.

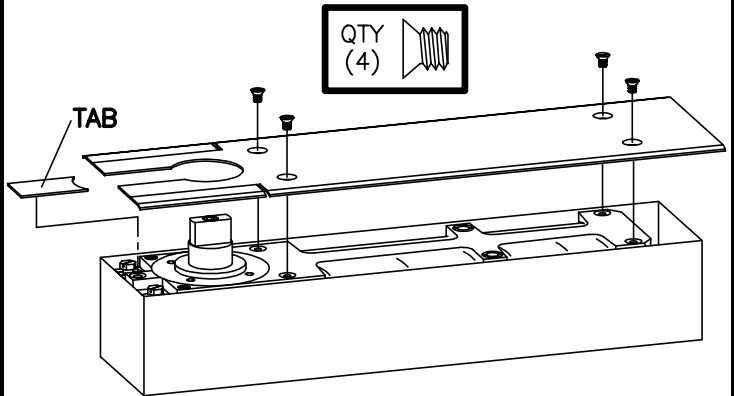

- 12 Sealing compound (Optional)

Sealing compound is recommended for exterior doors or areas with excessive moisture. Make all final adjustments before adding compound. Refer to instructions packed with compound for full details.

## CEMENT CASE

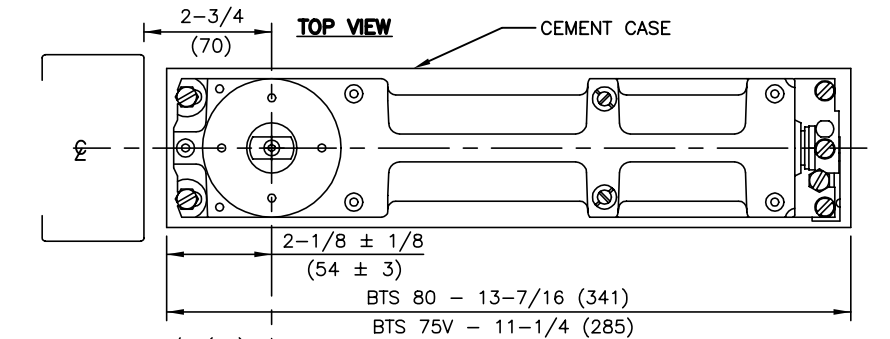

### NOTES

- DO NOT SCALE DRAWING.
- DIMENSIONS ARE IN INCHES/(mm).
- TOP OF CEMENT CASE MUST BE FLUSH WITH FINISH FLOOR LINE.
- CEMENT CASE MUST BE LEVEL AND PARALLEL TO FRAME.
- INSTALL CEMENT CASE WITH CLOSER CENTERED IN CASE.
- CHART VALID ONLY WHEN CORRESPONDING DOOR PORTION IS INSTALLED PER TEMPLATE.

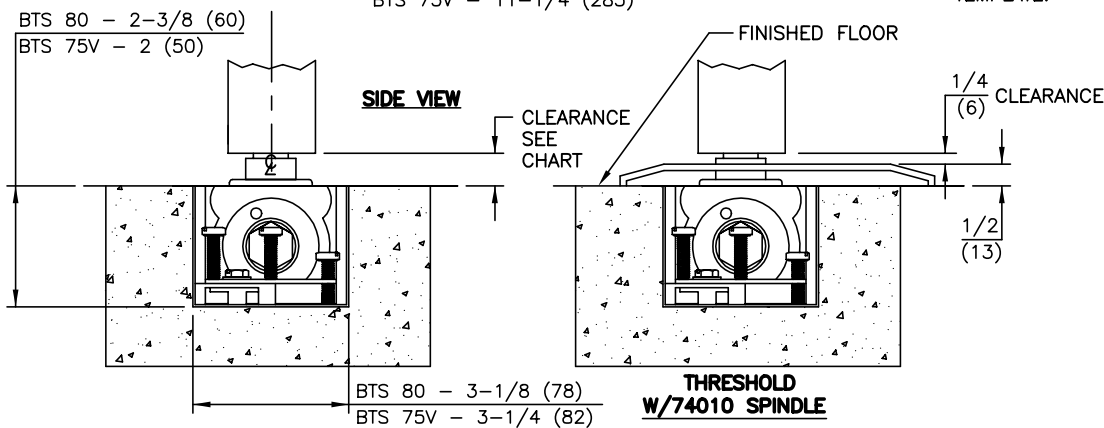

SPINDLE NO.	CLEARANCE
74003	5/16"
74005	1/2"
74007	5/8"
(STD.) 74010	3/4"
74012	13/16"
74015	7/8"
74020	1-1/8"
74025	1-5/16"
74030	1-1/2"
74035	1-11/16"
74040	1-7/8"
74045	2-1/16"
74050	2-5/16"

# TOP PIVOT

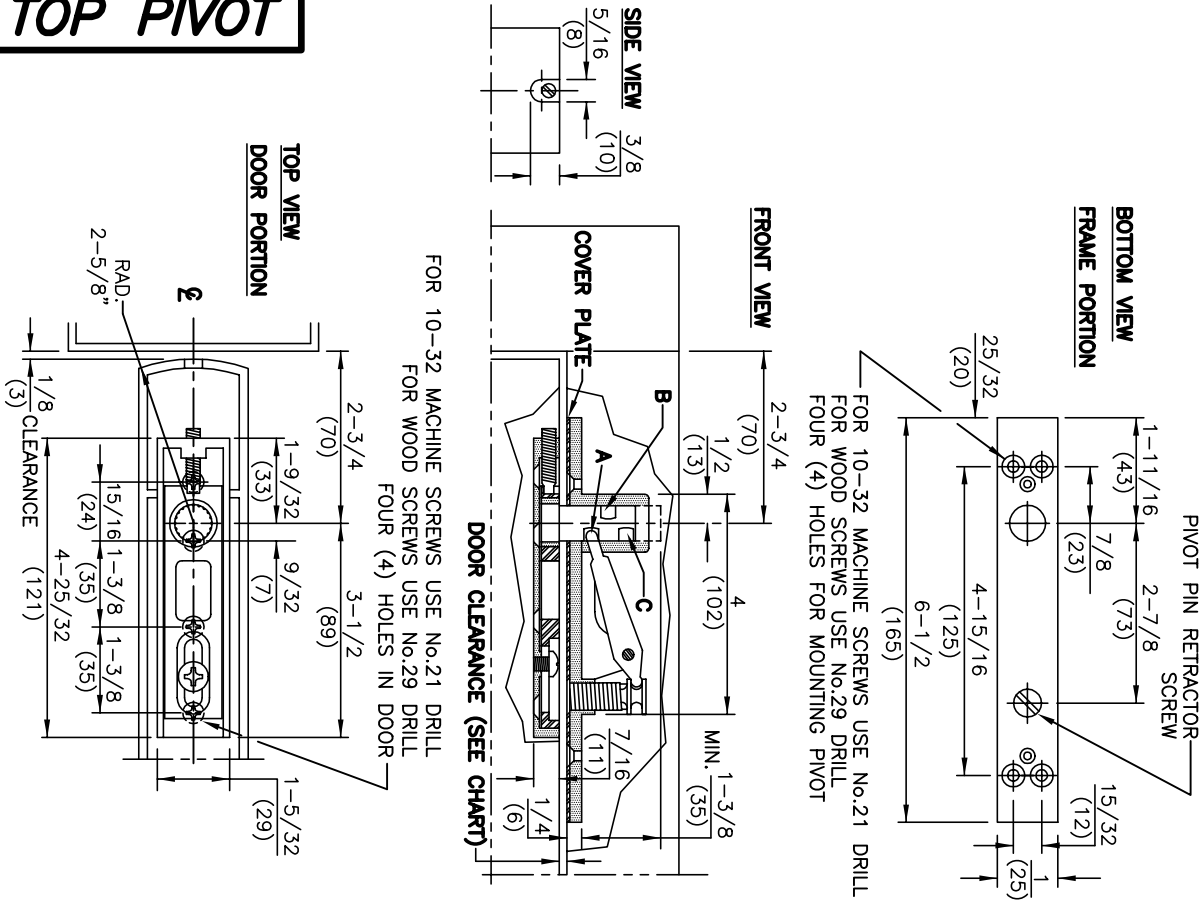

- NOTES**
- DO NOT SCALE DRAWING.
  - DIMENSIONS ARE IN INCHES/(MM).
  - ALL NECESSARY REINFORCING FOR PIVOTS BY OTHERS.
  - PIVOT PIN DIAMETER .591/(15MM).
  - PIVOT PIN PROJECTION IS ADJUSTABLE. SEE CHART FOR DOOR CLEARANCES.

DOOR CLEARANCE		
POSITION	STANDARD PIN	EXTENDED PIN
A	1/8" (3)	3/4" (19)
B	3/8" (10)	1" (25)
C	3/4" (19)	1-5/16" (33)

# BOTTOM ARM

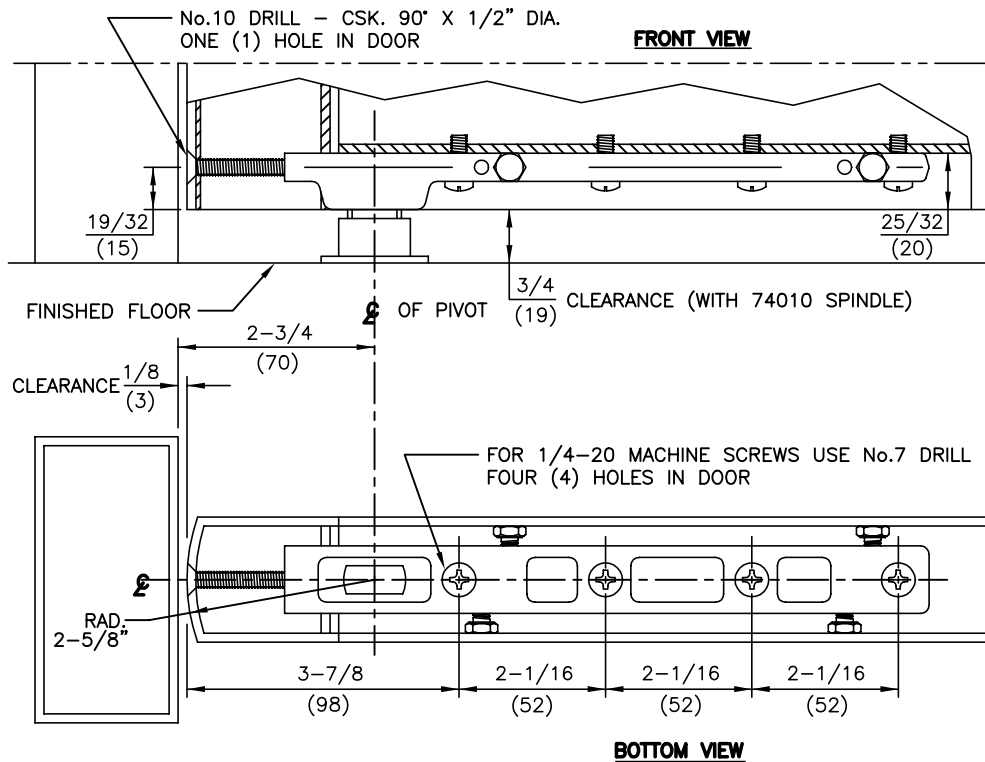

- NOTES**
- DO NOT SCALE DRAWING.
  - DIMENSIONS ARE IN INCHES/(MM).
  - ALL NECESSARY REINFORCEMENT FOR ARM BY OTHERS.