



TS93 GSR/EMF T 1A, 1I, 2



Surface applied door closer

Installation instructions:

Pull side track mount and coordinator system (GSR/EMF T)

TABLE OF CONTENTS



Technical specifications	
	Size selection chart 2
Closer setup	
	Surface closer system
	Handing of the door
	Tools required 3
INSTALLATION INSTRUCTIONS	
	Installing the backplate
	Installing the surface closer 4
	Installing the slide channel 5
	Installing the main arm 5-6
	Installing the coordinator system 6
	Installing conduit for EMF 7
	Wiring the EMF 8
ADJUSTMENTS	
	Adjusting the closing speeds
	Setting the hold open 9
	Adjusting the spring force 10
	Installing the closer and track cover 10

Technical specifications

Size selection chart

Closer	Interior/ Exterior	Door Width						
		1'-3" min.	2'-6" max.	3'-0" max.	3'-6" max.	4'-0" max.	4'-6" max.	5'-0" max.
TS9315	Interior	•	•	♿	♿	♿	N/A	N/A
TS9356	Interior	N/A	N/A	N/A	N/A	•	•	•

NOTES

Caution: sex nuts are required for attachment of components to unreinforced doors and to wood or plastic faced composite type fire doors, unless an alternative method is identified in the individual door manufacturer's listings.

Maximum door opening degree is 175°.

Minimum door width is 15".

Hold open range is from 80° to 130° with optional hold open kit.

A carry bar should be installed to insure that the active door is opened enough for the inactive door to close. Recommended carry bars:
DORMA carry bar MK-397 (up to 3'-6" wide door)
DORMA carry bar MK-398 (3'-6" and wider door)
Installation instructions are included with carry bar.

GSR/EMF T 11

(Active door & inactive door holds open together)

The GSR/EMF T 11 incorporates an electric hold open mechanism in the inactive leaf. The coordinator mechanism tied to the inactive leaf in turn holds the active leaf at whatever degree of opening it is placed. Both doors will close in sequence (inactive first) from any point upon signal from the fire alarm system or when electrical current is interrupted.

GSR/EMF T 1A (Active door hold open)

The GSR/EMF T 1A incorporates an electrical hold open mechanism in the active leaf. This eliminates the need to hold the inactive leaf in the open position to initiate hold open of the active leaf. This version permits the active leaf to be held open at a preselected point when the inactive leaf is in the closed position. The door will close from any point upon signal from the fire alarm system or when electrical current is interrupted.

GSR/EMF T 2 (Active door hold open only or inactive & active hold open together)

The GSR/EMF T 2 incorporates an electric hold open mechanism in both door leaves. This enables both leaves to be held open when the inactive door is placed in the preselected hold open position and also enables the active door to be held open independently when the inactive door is in the closed position. Both doors will close in sequence (inactive first) from any point upon signal from the fire alarm system or when electrical current is interrupted.

TS93 GSR/EMF T 1A, 1I, 2 PULL SIDE, REGULAR MOUNT

Closer setup

- ⚠ Follow included template to properly prepare door frame for all accessories of the closer installation.

⚠ Know the swing of the door which is being installed prior to installation.
- ⚠ Verify closer spring size prior to installation. See "Size selection chart" on page 2.

⚠ Make sure door efficiently operates prior to installing closer.

Surface closer system

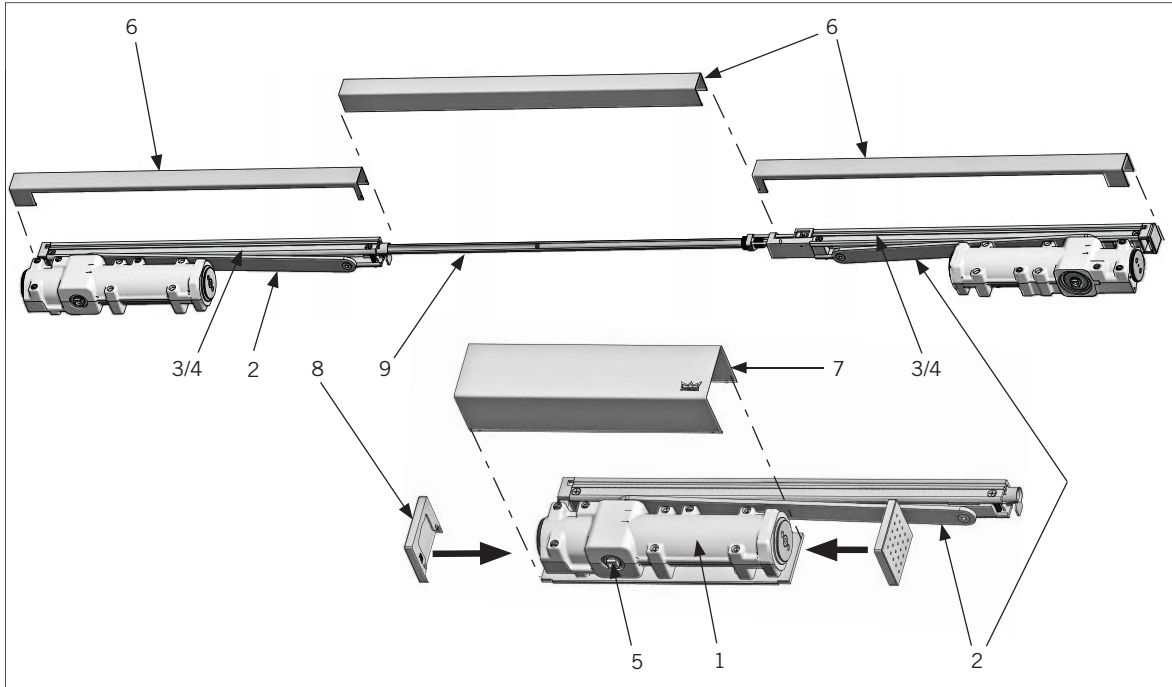

The surface closer is comprised of the following components.

- | | |
|--|--|
| <ol style="list-style-type: none"> 1. Closer body: "B" body 2. Main arm 3. Active track assembly 4. Inactive track assembly 5. Pinion | <ol style="list-style-type: none"> 6. Track covers and center cover 7. Closer cover 8. Closer end caps 9. Connecting channel |
|--|--|

Handing the door

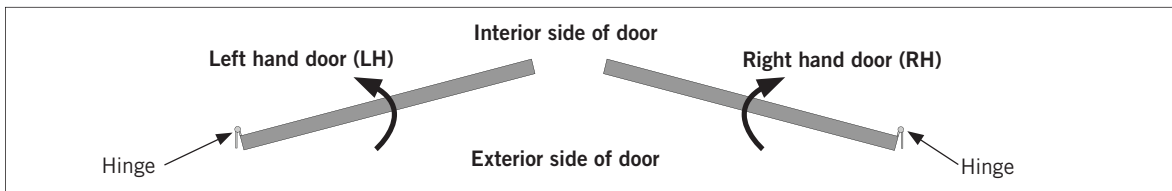

Tools recommended

- | | |
|---|--|
| <ul style="list-style-type: none"> ▪ Drill Bits <ul style="list-style-type: none"> Metal: No. 21 & 10-32 Tap Wood: 1/8" | <ul style="list-style-type: none"> ▪ Pozidriv PZ-2 ▪ #2 Phillips screwdriver ▪ 3/16" flat head screwdriver ▪ M2 & M5 Hex key |
|---|--|

TS93 GSR/EMF T 1A, 1I, 2 PULL SIDE, REGULAR MOUNT

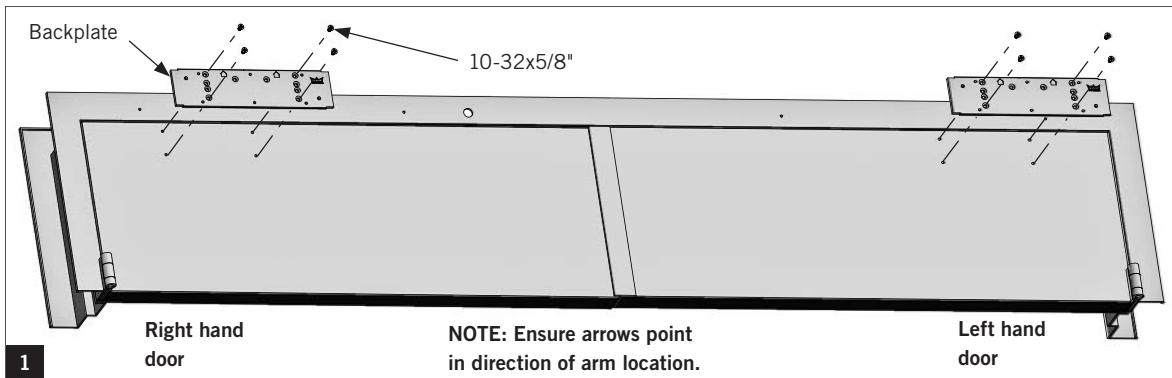

1.1 Secure plate to door.

- Use four 10-32 x 5/8" PH screws [#10 x 1-1/2" wood screws] provided.

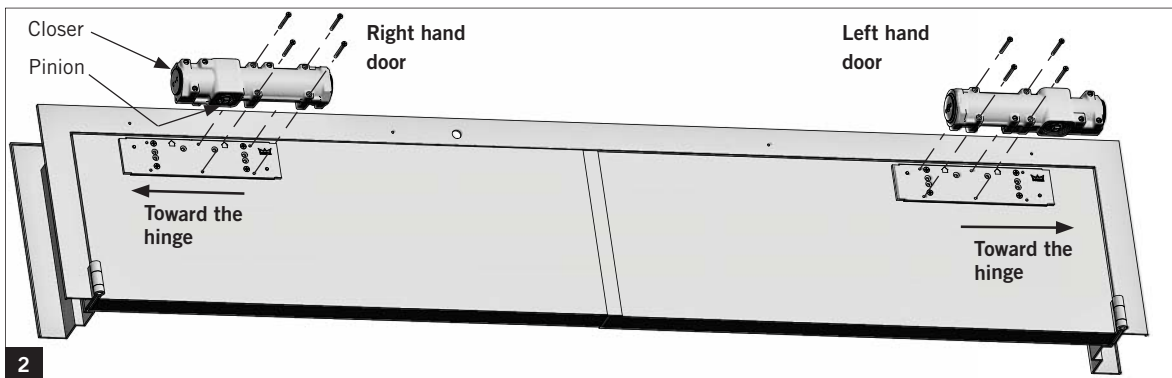

NOTE: Orient pinion closest to hinge.

2.1 Secure closer body to plate.

- Use four M5 x 47mm screws for each closer.

NOTE: Use **ONLY** a hand Phillips bit driver #2 or Pozidriv PZ-2.

TS93 GSR/EMF T 1A, 1I, 2 PULL SIDE, REGULAR MOUNT

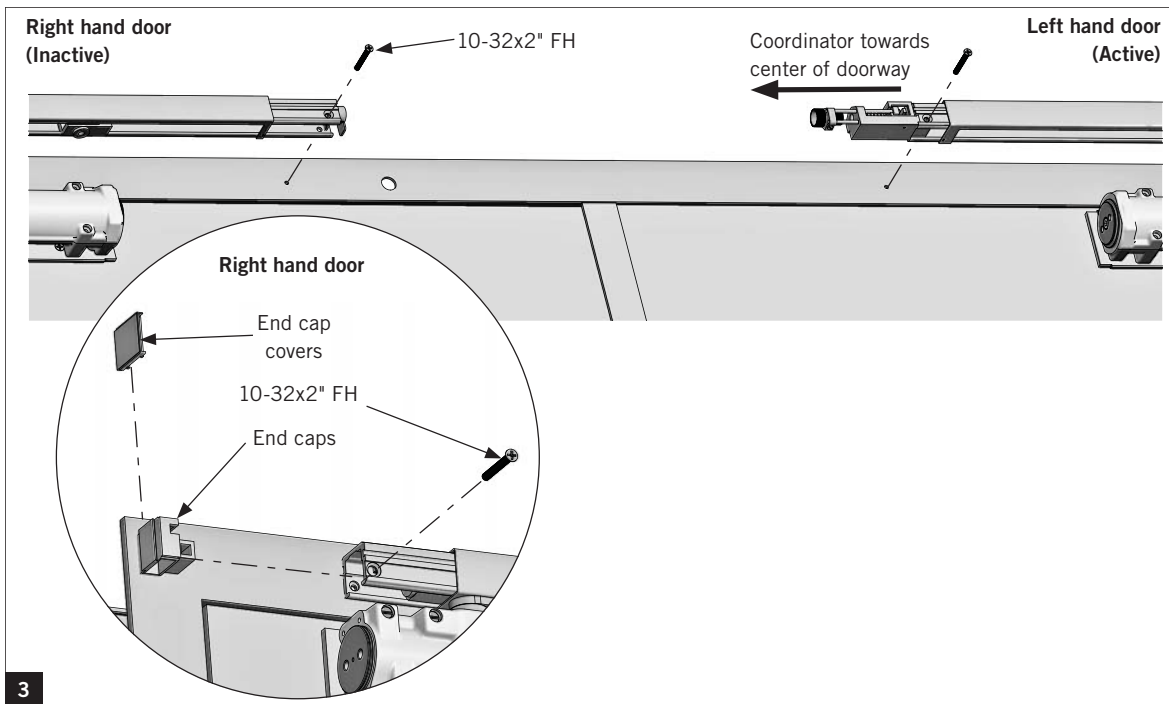

3

NOTE: EXAMPLE: Left hand active door shown. For right hand active installations, install active track assembly on right hand door and inactive track assembly on left hand door.

- | | |
|---|---|
| <p>3.1 Orient track with coordinator toward center of doorway.</p> <p>3.2 Secure track to door frame via holes closest to center of door first.</p> <ul style="list-style-type: none"> ▪ Use two 10-32x2" FH screws. | <p>3.3 Insert end caps into track.</p> <p>3.4 Secure end of track through end caps.</p> <ul style="list-style-type: none"> ▪ Use two 10-32x2" FH screws. <p>3.5 Slide end cap covers onto end caps.</p> |
|---|---|

Installing the main arm

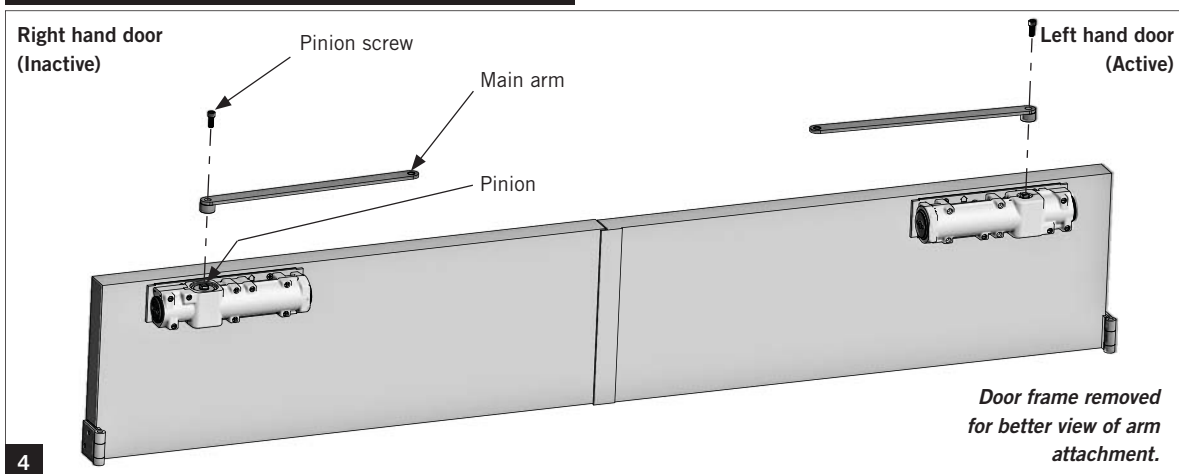

4

- | | |
|--|---|
| <p>4.1 Attach 1/2" wrench to bottom pinion.</p> <p>4.2 White looking up, rotate pinion (square) until it aligns to square hole on arm.</p> <p style="margin-left: 20px;">LH = turn 5° counter-clockwise
RH = turn 5° clockwise</p> | <p>4.3 Arm is parallel to door.</p> <p>4.4 Secure with M6x20 socket head fastener.</p> <ul style="list-style-type: none"> ▪ Use an M5 hex key. |
|--|---|

TS93 GSR/EMF T 1A, 1I, 2 PULL SIDE, REGULAR MOUNT

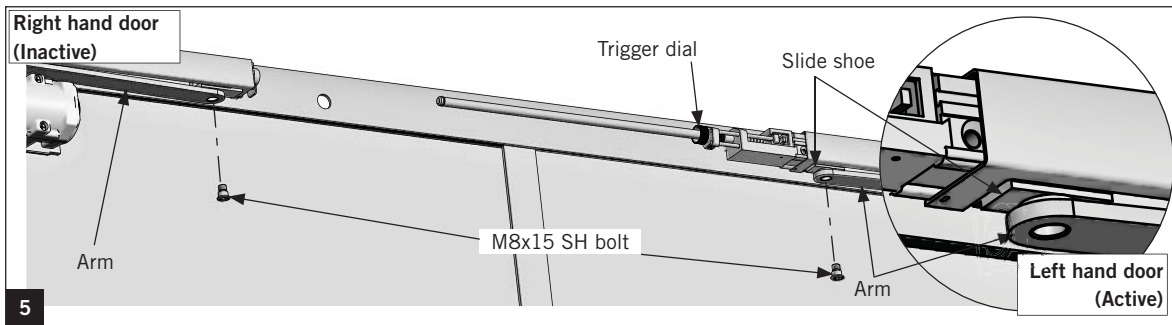

5.1 Secure arm to slide shoe.

- Use one M8x15 shoulder bolt and a 5mm hex key.

NOTE: Depress trigger dial to allow active slide shoe to move freely. If locking pin falls out, discard after completing installation.

Installing the coordinator system

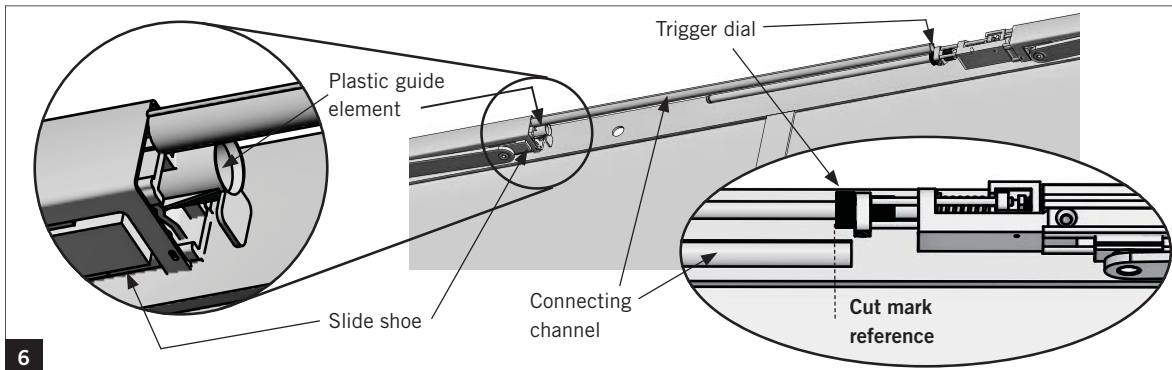

6.1 Close both door leaves.

6.2 Push plastic guide element up against slide shoe.

6.3 Fully wind trigger dial (towards door frame).

6.4 Align connecting channel with trigger dial per image above.

6.5 Mark and cut connecting channel.

TS93 GSR/EMF T 1A, 1I, 2 PULL SIDE, REGULAR MOUNT

Installing conduit for EMF

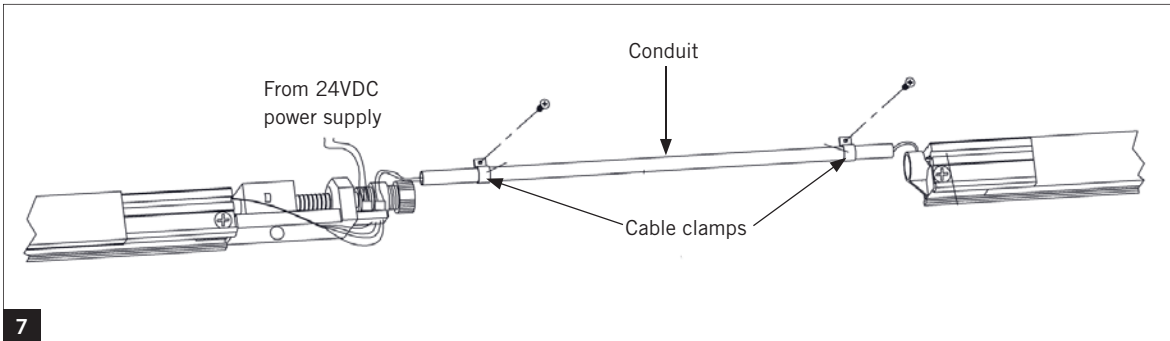

7.1 Secure conduit to mounting surface with cable clamps included.

- Use two 8-32 x 5/8" screws.

7.2 Feed wires through conduit.

NOTE: Must run inactive solenoid wire through conduit on wall side of track.

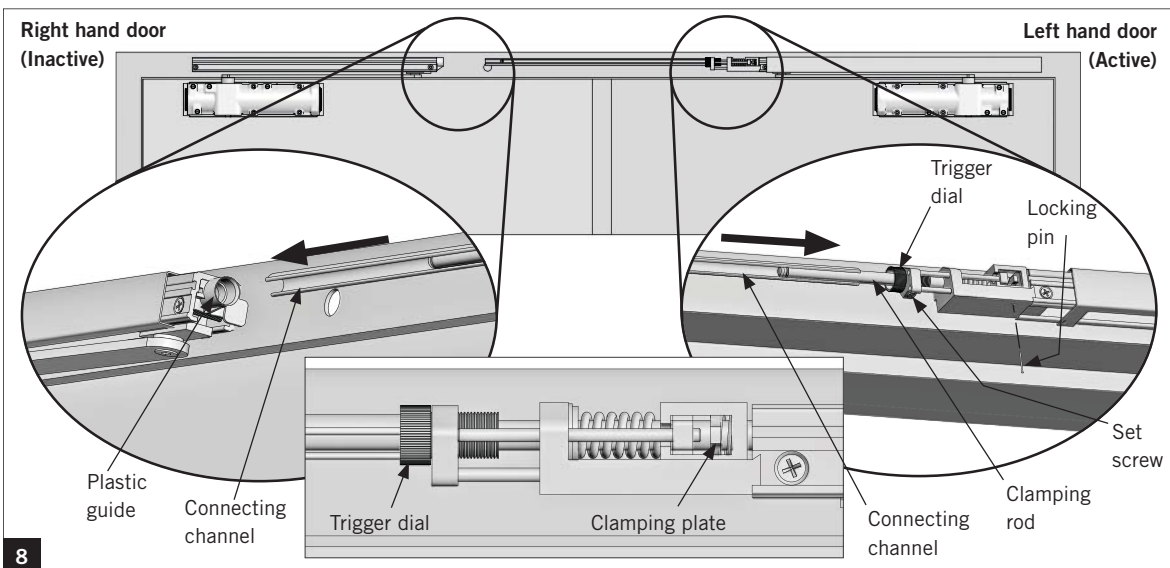

8.1 Open active leaf to retract clamping rod.

8.2 Active door: Insert connecting channel into trigger dial.

8.3 Inactive door: Insert connecting channel into plastic guide.

8.4 Unwind trigger dial (**away from door frame**) until active door starts to close. **Clamping plate should be perpendicular to clamping rod.**

8.5 Tighten set screw to secure trigger dial.

NOTE: The locking pin can be discarded once system has been installed.

TS93 GSR/EMF T 1A, 1I, 2 PULL SIDE, REGULAR MOUNT

Wiring the EMF

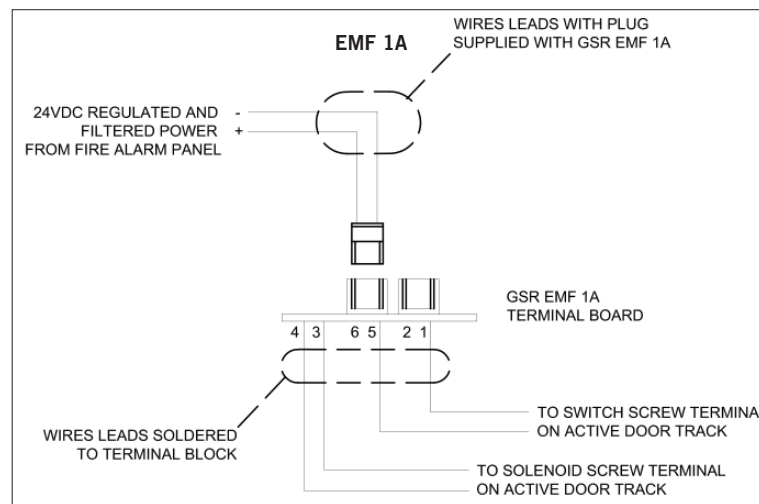
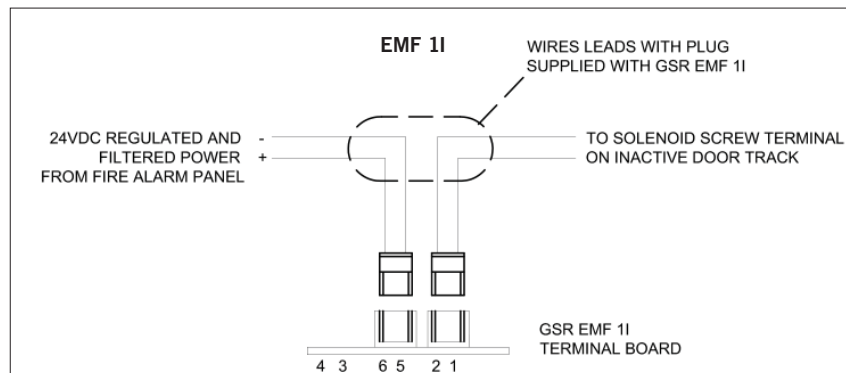
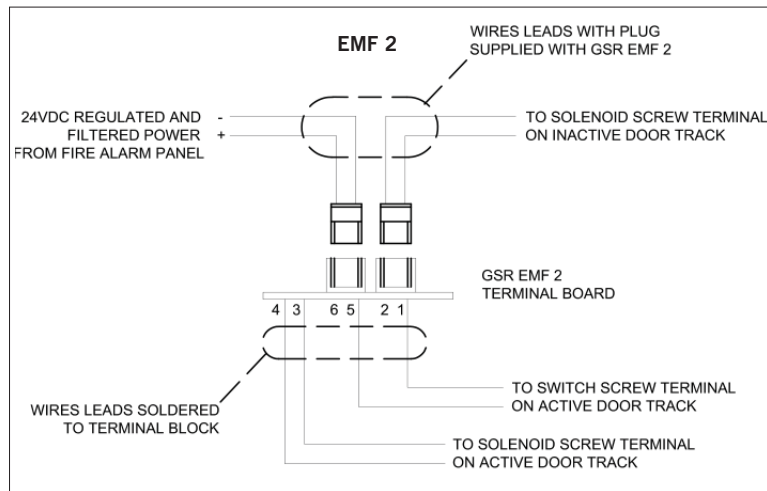

9

9.1 Determine appropriate EMF unit and follow steps below:

EMF 2: Plug in wire harness into terminals 1 and 2 (active door track) of the 6-pin terminal block.

EMF 1I: Plug in wire harness to terminals 1 and 2 (active door track) of the 6-pin terminal block.

EMF 1A: No plug in wire harness to 6-pin terminal block of active door.

NOTE: Be sure power is off prior to making following connections:

9.2 Connect power wire harness to 24 VDC power supply.

9.3 Plug in power wire harness to terminals 5 and 6 (active door track) of 6-pin terminal block.

TS93 GSR/EMF T 1A, 1I, 2 ADJUSTMENTS

Adjustments

- ⚠ Confirm closer spring size prior to making any closing speed adjustments.
- ⚠ Do not back valve heads out beyond closer casting.

- ⚠ Maximum opening angle is 175°.
- ⚠ Door should close in 3 to 6 seconds from 90°.
- ⚠ Do not close valves completely.

Adjusting the closing speeds: sweep, latch or backcheck and delayed action

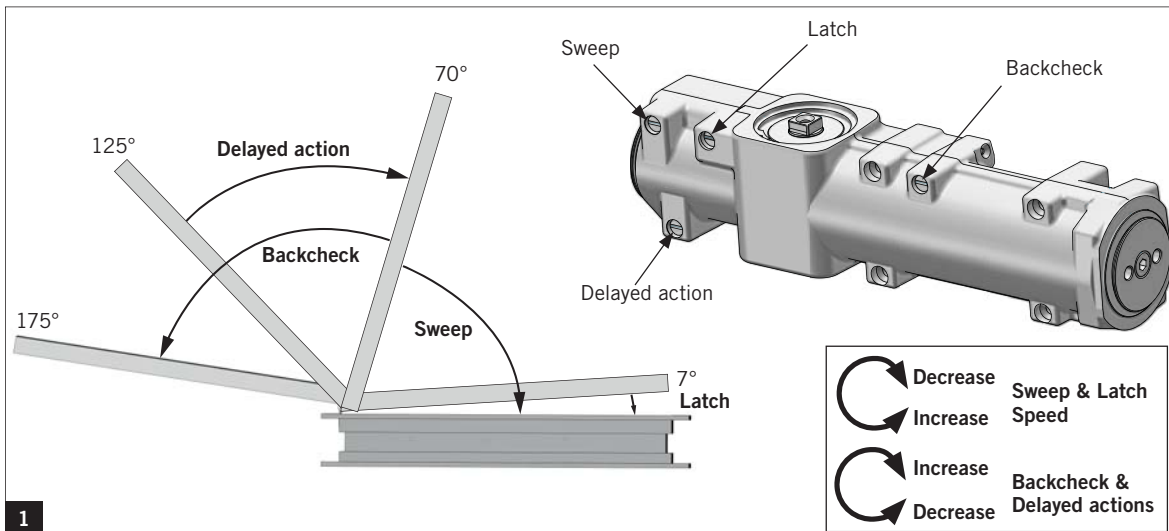

1.1 Adjust closing **sweep speed**: 70° to start of latch speed.

- Increase sweep speed: Turn valve counter-clockwise
- Decrease sweep speed: Turn valve clockwise.

1.2 Adjust closing **latch speed**: 7° to close.

- Increase latch speed: Turn valve counter-clockwise

1.3 Adjust opening **backcheck**: beginning at 70°.

- Increase resistance: Turn valve clockwise
- Decrease resistance: Turn valve counter-clockwise.

1.4 Adjust closing **delayed action**: 125° to start of sweep.

- Increase delayed action: Turn valve clockwise
- Decrease delayed action: Turn valve counter-clockwise

Setting the hold open

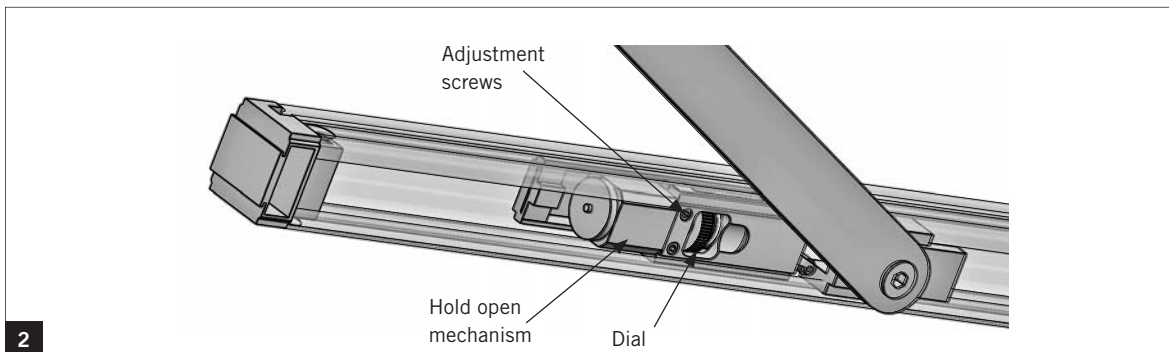

2.1 Adjust door position:

- *Adjust hold open angle*: loosen adjustment screws using an M2 hex key.
- Slide hold open mechanism to desired location and re-tighten adjustment screws.

2.2 Hold open activation:

- Place door in hold open.
- Deactivate: When clips are released from slide shoe.
- Activate: When clips are pressed against inside of slide shoe.

2.3 Adjust hold open force:

- Decrease force: spin dial away from door frame
- Increase force: spin dial towards door frame

NOTE: Do not set release force too high. Damage may occur to door, hinges or GSR system.

TS93 GSR/EMF T 1A, 1I, 2 ADJUSTMENTS

Adjusting the spring force

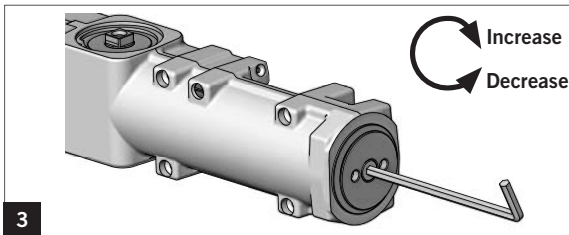

TS9315

NOTE: Supplied with a size 2 spring setting.

Barrier free openings: Take an opening force reading from pull on door. If required, adjust spring force to meet barrier-free requirement.

- **Decrease force:** turn counter-clockwise
- **Increase force:** turn clockwise

Depending on opening conditions, a door adjusted to meet barrier-free forces may not have sufficient power to reliably close and latch the door.

TS9356

NOTE: Supplied with a size 6 spring setting.

- **Increase force:** turn clockwise 6 times (max)

Spring size chart

Regular Mount, Pull side closers					
	Closer size	Max door weight (lbs)	Door width		Full turns
			Interior	Exterior	
TS9315	2	100	2'6"	---	+5
	3	125	3'	2'6"	+9
	4	150	3'6"	3'	+14
	5	200	4'	3'6"	+18
TS9356	5	200	4'	3'6"	-4
	6	250	4'6"	4'	0

Installing the closer and track covers

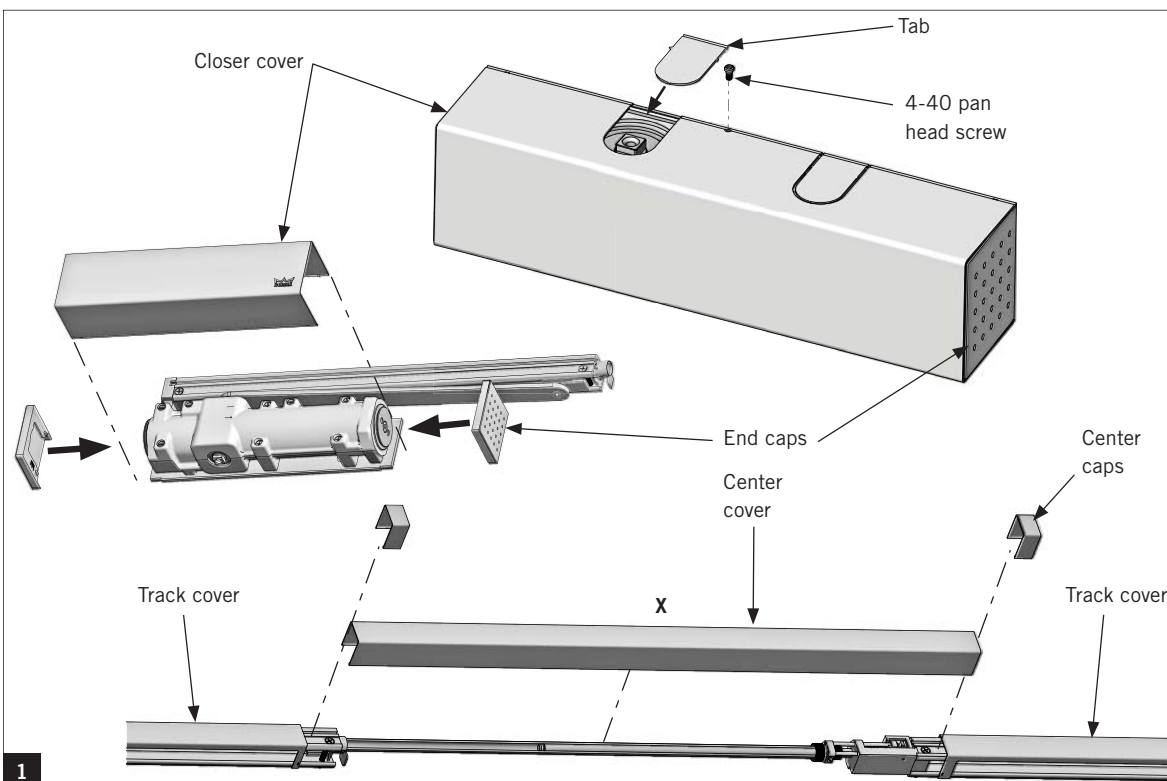

1

- 1.1 Snap both end covers onto closer body end caps.
- 1.2 Remove un-needed tab, and snap cover over closer body.
- 1.3 Secure with one 4-40 Phillips pan head screw.

- 1.4 **Center cover:** Measure distance between track covers, and subtract 1/2". [$X - 1/2"$ = center cover length]
- 1.5 Cut center cover to length measured, and slide over coordinator system.
- 1.6 Snap center caps on to track.



DORMA USA, INC.
DORMA DRIVE, DRAWER AC
REAMSTOWN, PA 17567
TOLL-FREE: 800-523-8483
FAX: 800-274-9724
WEBSITE: WWW.DORMA-USA.COM