

Door Closer Models: EHD9016 SPA x FTHD Parallel Arm Installation [Push Side Mount] Flush Transom Bracket Drilling Instructions

For online instructions, assistance or warranty information:
Call 1-800-392-5209 or visit <https://dhwsupport.dormakaba.com/hc/en-us>

NOTES:

1. DRAWING IS NOT TO SCALE.
2. DIMENSIONS ARE IN INCHES / [MM].
3. RIGHT HAND DOOR SHOWN.
4. CAUTION: SEX NUTS ARE REQUIRED FOR ATTACHMENT OF COMPONENTS TO UNREINFORCED DOORS AND TO WOOD OR PLASTIC FACED COMPOSITE TYPE FIRE DOORS, UNLESS AN ALTERNATIVE METHOD IS IDENTIFIED IN THE INDIVIDUAL DOOR MANUFACTURER'S LISTINGS.
5. MINIMUM DOOR WIDTH 26".
6. TEMPLATING BASED ON 4-1/2" X 4-1/2" BUTT HINGES.
7. MAXIMUM OPENING 180° SHOWN.
8. DPK FASTENERS FOR STEEL DOOR & FRAME ONLY.

FOR 1/4-20 MACHINE SCREWS, USE 13/64" OR #7 DRILL & TAP
FOR No. 14 WOOD SCREWS, USE 5/32" DRILL
FOR DPK FASTENERS, USE 1/8" DRILL
FOUR (4) HOLES IN TRANSOM FOR FTHD BRACKET

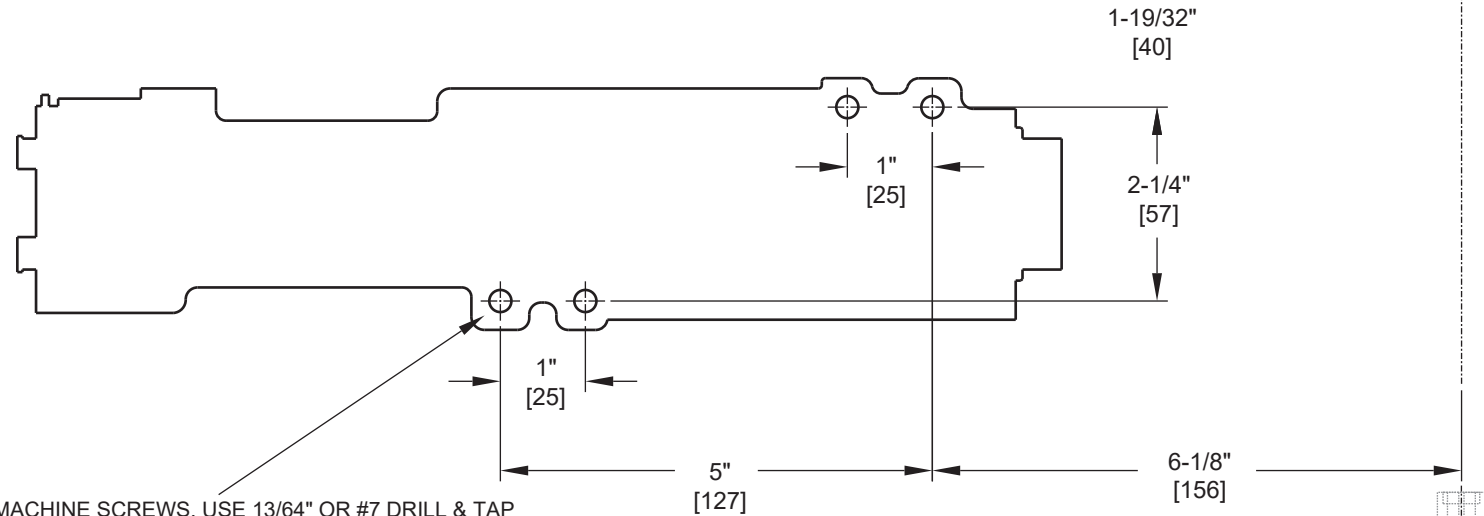
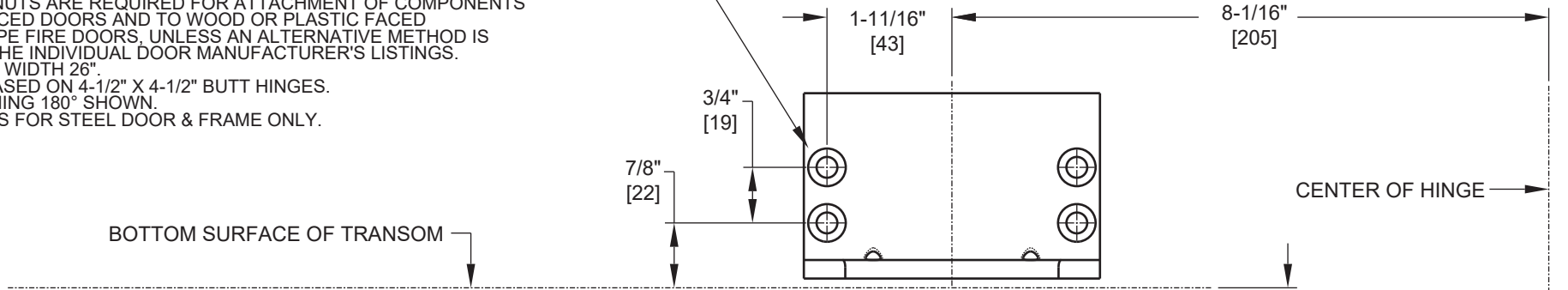

FOR 1/4-20 MACHINE SCREWS, USE 13/64" OR #7 DRILL & TAP
FOR No. 12 WOOD SCREWS, USE 9/64" DRILL
FOR DPK FASTENERS, USE 1/8" DRILL
FOR SEX NUTS, USE 3/8" DRILL
FOUR (4) HOLES IN DOOR FOR CLOSER

LEFT HAND DOOR ORIENTATION:

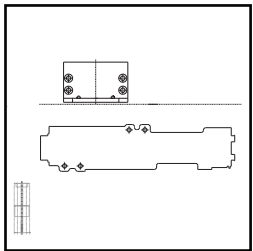

Not to scale. Measurements are for reference only.
Not a drilling template.