

Door Closer Models: EHD9016 SDST x FTHD Door Saver Arm Flush Transom Installation [Push Side Mount] With Backplate BP90 Drilling Instructions

For online instructions, assistance or warranty information:
Call 1-800-392-5209 or visit <https://dhwsupport.dormakaba.com/hc/en-us>

NOTES:

1. DRAWING IS NOT TO SCALE.
2. DIMENSIONS ARE IN INCHES / [MM].
3. RIGHT HAND DOOR SHOWN.
4. CAUTION: SEX NUTS ARE REQUIRED FOR ATTACHMENT OF COMPONENTS TO UNREINFORCED DOORS AND TO WOOD OR PLASTIC FACED COMPOSITE TYPE FIRE DOORS. UNLESS AN ALTERNATIVE METHOD IS IDENTIFIED IN THE INDIVIDUAL DOOR MANUFACTURER'S LISTINGS.
5. MINIMUM DOOR WIDTH 26".
6. TEMPLATING BASED ON 4-1/2" X 4-1/2" BUTT HINGES.
7. MAXIMUM OPENING 110° SHOWN.
8. DPK FASTENERS FOR STEEL DOOR & FRAME ONLY.

FOR 1/4-20 MACHINE SCREWS, USE 13/64" OR #7 DRILL & TAP
FOR No. 14 WOOD SCREWS, USE 5/32" DRILL
FOR DPK FASTENERS, USE 1/8" DRILL
FOUR (4) HOLES IN TRANSOM FOR FTHD BRACKET

Bracket Center Distance	Hold Open Angle
11-3/16" [284]	85°
10-7/16" [265]	90°
9-3/16" [233]	100°
8-1/8" [206]	110°

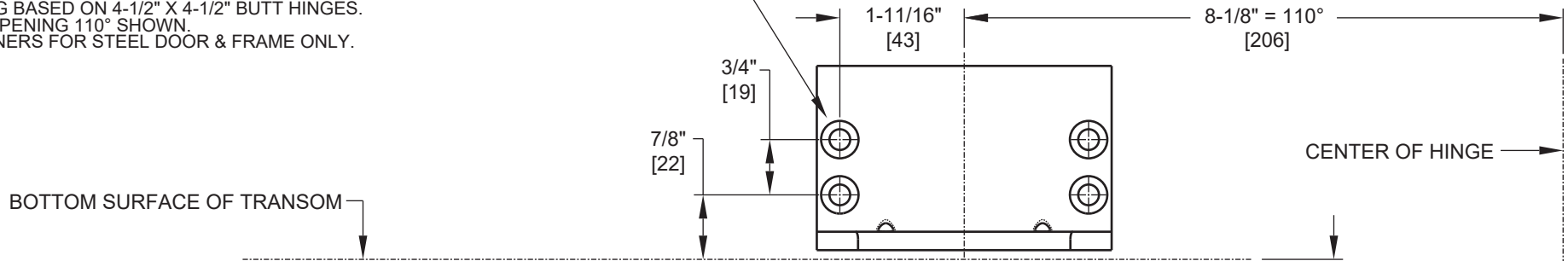

FOR 12-24 MACHINE SCREWS, USE 11/64" OR #16 DRILL & TAP
FOR No. 12 WOOD SCREWS, USE 9/64" DRILL
FOR DPK FASTENERS, USE 1/8" DRILL
FOR SEX NUTS, USE 3/8" DRILL
FOUR (4) HOLES IN DOOR FOR PLATE

CLOSER INSTALLS TO TOP SETS OF SMALL HOLES USING #12-24 MACHINE SCREWS

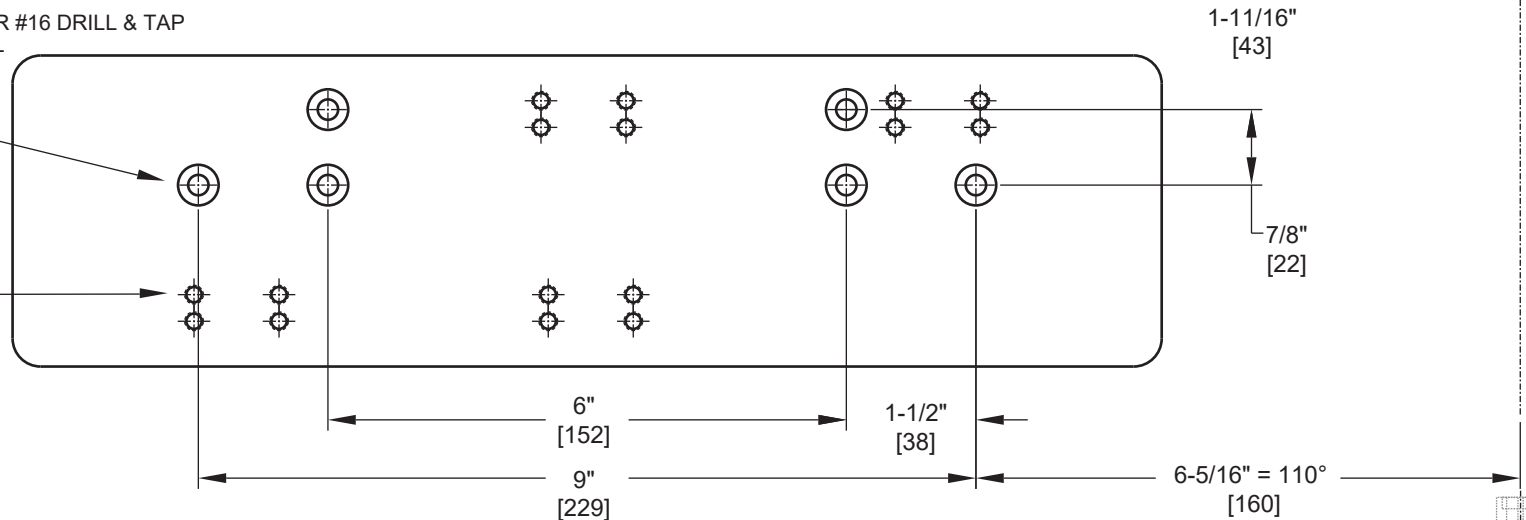

LEFT HAND DOOR ORIENTATION:

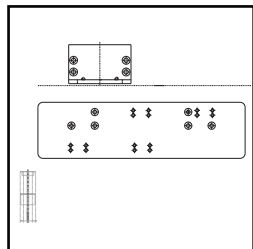

Backplate Distance	Hold Open Angle
9-3/8" [238]	85°
8-5/8" [219]	90°
7-3/8" [187]	100°
6-5/16" [160]	110°

Not to scale. Measurements are for reference only.
Not a drilling template.